



L1810 Gen 2.6 LASER CUTTER



User Manual
Rev 002

Registering the laser cutter

Please register the laser cutter on the following link:

<https://www.summa.com/support/product-registration/>

Failure to register the laser cutter may result in a delayed response to warranty and service inquiries.

Contact Information

All inquiries, comments or suggestions concerning this and other Summa manuals should be directed to:

Summa, nv
Rochesterlaan 6
B-8470 GISTEL
Belgium

Website

www.summa.com

Copyright © Summa NV

Congratulations on Your Purchase of the New L1810 Gen2.6 Laser Cutter!

Summa's professional laser cutting systems have been developed with years of experience in advanced finishing technology. Summa strives to empower you with laser cutting solutions to bring exceptional quality, smart processing, extended automation, and unsurpassed accuracy to your workflow.

Textile is one of the fastest growing markets, where on-demand digital printing proves to be the game changer many soft signage, sportswear and fashion brands are looking for. Printed textiles require flawless finishing and absolutely nothing cuts as accurately as lasers do.

The contactless cutting method of laser equipment means no fabric distortion, low to no dust generation, no tool wear and no fraying of textiles or fabrics thanks to perfectly sealed edges. Even most intricate details are a breeze to cut with Summa laser cutting technology.

Discover the many other advantages Summa laser cutting technology has to offer in this manual. Also, an overview of main components of the L1810 Gen2.6, operating procedures and safety precautions are being explained in this manual.

All information in this manual must be read and understood before any attempt to operate the machine is made.

Revision history

Version	Reason for modification	Publication date	Author
001	Original version. (← L1810 Gen2 rev004)	July 2024	WVRB
002	Update chapter 3.1.1 Control panel functions in GoProduce Laser Edition Update chapter 4.1.1.2.2 Start alignment procedure	November 2024	WVRB, AL

Table of Contents

1	Safety	8
1.1	Safety	8
1.1.1	General.....	8
1.1.2	Symbols used in this manual	8
1.1.3	Safety symbols on the machine	9
1.1.4	Safety precautions	10
1.1.4.1	Danger area during operation	10
1.1.4.2	Safety precautions related to movement	10
1.1.4.3	Safety precautions related to the built-in laser.....	10
1.1.4.4	Safety precautions related to the system components	11
1.1.4.5	Safety precautions related to the extraction system	11
1.1.4.6	Safety precautions related to the material	11
1.1.4.7	Safety precautions related to fire	11
1.1.5	Safety features	11
1.1.5.1	Emergency stop buttons	11
1.1.5.2	Safety cover lid and finger safety plates	12
1.1.6	Personal protective equipment	12
1.2	Operating environment	12
2	Laser cutting system components	13
2.1	Laser Cutter	14
2.1.1	Front view.....	14
2.1.2	Rear view	15
2.1.3	Main power switch.....	16
2.1.4	ON/OFF buttons	16
2.1.5	Emergency stop buttons	16
2.1.6	Ethernet connection	16
2.1.7	Safety cover lid.....	16
2.1.8	Finger safety plates.....	16
2.1.9	Conveyor system	17
2.1.10	Fume extraction system	17
2.1.11	Cutting head nozzle	18
2.1.11.1	Nozzle height	18
2.1.12	Head camera.....	19
2.1.13	Pressure rollers	19
2.1.14	Feed button	19
2.1.15	Vision camera gantry (optional)	19
2.2	Unwinder (optional)	20
2.3	Fume extraction and vacuum system	21
2.3.1	Air filtration units (optional).....	21
2.3.2	Extraction fan (optional)	21
2.4	Water chiller (optional)	22
2.4.1	General Description	22
2.4.2	Temperature.....	23
2.4.3	Safety precautions	23
3	Starting up the laser cutter	24
3.1.1	Control panel functions in GoProduce Laser Edition	25

3.1.1.1	Media.....	25
3.1.1.2	Actions.....	27
3.1.1.3	Configuration.....	27
3.1.1.4	Info	27
3.1.1.5	Monitor	28
4	Maintenance.....	29
4.1	Laser cutter	29
4.1.1	Laser beam alignment.....	30
4.1.1.1	Required tools and parts	30
4.1.1.2	Preparation.....	31
4.1.1.2.1	Covers.....	31
4.1.1.2.2	Start alignment procedure.....	32
4.1.1.3	Laser alignment.....	33
4.1.1.3.1	Components	33
4.1.1.3.2	Check corners	34
4.1.1.3.3	Primary mirror calibration	38
4.1.1.3.4	Secondary mirror.....	43
4.1.1.3.5	Third (45° angled) mirror	48
4.1.1.3.6	Final corners check	51
4.1.2	Optical components	53
4.1.2.1	Cleaning the primary mirror.....	54
4.1.2.2	Cleaning the secondary mirror	56
4.1.2.3	(Un)Installing the static and travelling mirrors.....	57
4.1.2.3.1	Removing the mirror.....	57
4.1.2.3.2	Installing the mirror.....	57
4.1.2.4	Cleaning the cutting head lens.....	58
4.1.2.5	Cleaning the cutting head mirror.....	61
4.1.2.6	Cleaning the Vision camera lenses.....	63
4.1.3	Pneumatics.....	64
4.1.3.1	Nozzle cleaning.....	64
4.1.3.2	Airflow.....	65
4.1.4	Axes	66
4.1.4.1	Axis movement.....	66
4.1.4.2	Clean rails	66
4.1.5	Air filters	67
4.1.6	Conveyor planks	68
4.2	Air-cooled laser	69
4.2.1	Laser unit.....	69
4.3	Water-cooled laser.....	70
4.3.1	Water-cooled laser unit	70
4.3.2	Chiller	71
4.3.2.1	Water level	71
4.3.2.2	Water quality	72
4.3.2.3	Water pipes	73
4.3.2.4	Chiller air filter	74
4.4	Extraction systems	75
4.5	Maintenance Overview	76

5 **Included accessories..... 78**

6 **Troubleshooting 79**

6.1 **Error Messages..... 80**

7 **GoCare 82**

8 **GoProduce Laser Edition 83**

1 SAFETY

1.1 Safety

1.1.1 General

The manufacturer has no direct control over the machine operation and application. Proper safety practice is the sole responsibility of the owner, user, and operator.

All instructions and safety warnings in this manual are based upon the use of this machine under proper operating conditions without alterations from the original design.

Any use of the laser cutter that is beyond the capabilities of the combination laser source/material is considered as improper use and may result in injury and/or serious damage to the machine and will lead to loss of warranty.

The installation of the machine, accessories, and spare parts must not be done by untrained or unauthorized persons. Also, the described maintenance procedures need to be followed and performed by trained personnel.

1.1.2 Symbols used in this manual



Warning with dark (red) symbol: Refers to immediate threat that can cause serious injuries and effects on health and safety.



Warning with light (yellow) symbol: Refers to a dangerous situation that can cause injuries and serious damage to the machine.



Attention with dark (red) symbol: Refers to useful information to prevent damage to the equipment and prolong the service life of the machine.



Attention with light (yellow) symbol: Refers to useful tips to enhance user-friendliness and make the work significantly easier.



Note: Can be considered as a general tip, something that is useful to know.

1.1.3 Safety symbols on the machine

Safety labels are used on some parts of the machine. They are explained below.

**Caution**

Servicing instructions are for use by qualified service personnel only.

To reduce the risk of electric shock, do not open the equipment and do not perform any servicing other than that contained in the operating instructions unless you are qualified to do so.

Unplug this equipment when not used for an extended period.

**Caution**

Class 1 Laser Product.

Class 4 invisible laser radiation when open.

Avoid eye or skin exposure to direct or scattered radiation.

**Caution**

Moving parts. Risk of trapping. Keep hands, clothing, jewellery, and hair away.

**Caution**

This equipment should only be used in a well-ventilated area.

Do not cover ventilation openings.

Periodic maintenance required.

Only use a CO₂ fire extinguisher on this equipment.

Compressed air hazard. Ensure that the air supply to the machine is disabled before disconnecting tubes.



Consult the user's manual.

Make sure to observe all the caution labels on the machine.

1.1.4 Safety precautions



WARNING: This equipment is not suitable for use in locations where children are likely to be present.

1.1.4.1 Danger area during operation

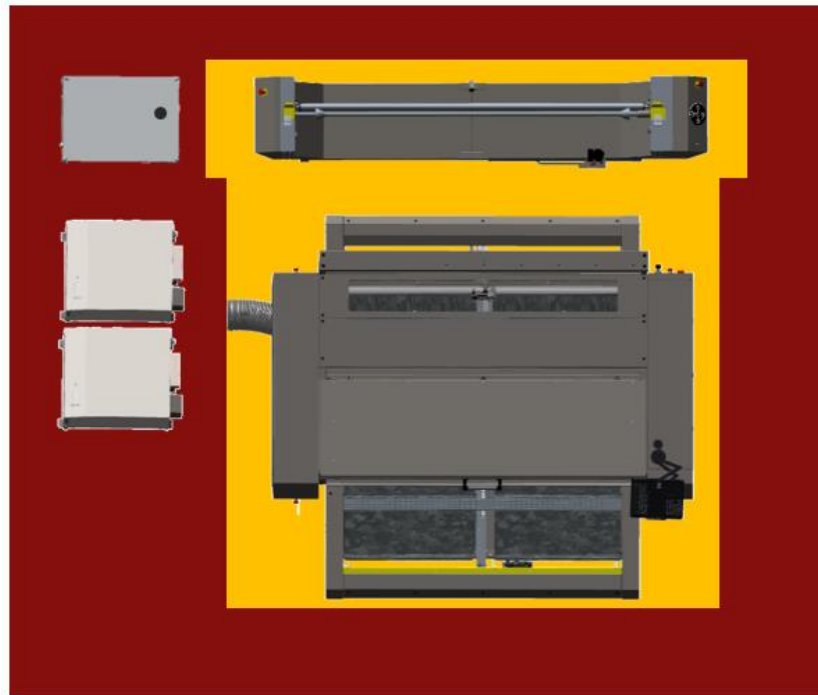

The general danger area is the yellow area: the complete area where the conveyor is moving, and the fabric roll is in motion. Anyone not operating the machine should keep a distance around the machine of at least one meter. Only the trained operator or fully trained personnel can be in this area. When the laser cutter is operating, do not leave it unattended at any time.

1.1.4.2 Safety precautions related to movement



WARNING: There is a risk of injury from being caught or trapped in moving machine parts. Keep hands, hair, clothing and jewellery away from moving parts. Do not wear jewellery, loose clothing, scarves, open jackets, or shirtsleeves.

1.1.4.3 Safety precautions related to the built-in laser

The laser emits invisible class 4 laser radiation; avoid skin exposure to direct or scattered laser light and do not stare into the laser beam. Wear laser safety goggles.



WARNING: Safety goggles must be worn.

Any person or organization performing any modification to the laser cutting system is responsible for ensuring the reclassification and relabelling of the laser product.

1.1.4.4 Safety precautions related to the system components

When closing the safety cover, ensure that no fingers or other items can be trapped between the safety cover and the side pod. When the safety cover is lifted, care must be taken to avoid bumping your head against it. The electrical enclosure (i.e., doors and cover pods, etc.) must only be opened by trained service personnel. The laser cutting system must not be operated with its shutter, guard, protective housings, or any of the safety interlocks removed.

1.1.4.5 Safety precautions related to the extraction system

Before commencing any cutting procedure ensure that the fume extraction system is in good working order and operates correctly. Ensure that any fumes are extracted in accordance with health and safety requirements.

1.1.4.6 Safety precautions related to the material

The laser cutter can process a broad range of materials. Choose only material types that do not generate harmful emission during the cutting process. Check with the material supplier or manufacturer before cutting. The following materials are not suitable for laser cutting:

- Leather and artificial leather that contains chromium (VI),
- Carbon fibres (Carbon),
- Polyvinyl chloride (PVC),
- Polyvinyl butyral (PVB),
- Polytetrafluoroethylenes (PTFE / Teflon),
- Beryllium oxide,
- Any materials containing halogens (fluorine, chlorine, bromine, iodine, and astatine), epoxy or phenolic resins.



WARNING: Respiratory equipment must be worn for airborne dust particles.

1.1.4.7 Safety precautions related to fire

A carbon dioxide fire extinguisher must be present in the vicinity of the cutting machine and the personnel concerned must be trained to use it in an emergency.

1.1.5 Safety features

1.1.5.1 Emergency stop buttons

Pressing an emergency stop button will shut down the machine immediately. The current cutting job will be lost. The system (and preferably the software as well) will have to be rebooted to restart the cutting process.

1.1.5.2 Safety cover lid and finger safety plates

When the safety cover lid of the cutting area is opened or the finger safety plates are triggered, the laser stops firing, and the cutting job is paused. A warning pops up on screen, prompting the operator to close the cover. The machine will resume operation when the covers have been closed.

1.1.6 Personal protective equipment

The required protective equipment depends on the material that will be processed. When operating or servicing the machine, the operator should wear appropriate protective equipment. This can include:

- Protective work clothing
- Respirator mask in case of toxic fumes
- Safety goggles: when processing the material, harmful particles can be generated.

1.2 Operating environment

Environmental conditions can significantly affect the machine's performance. Most restrictions or recommendations for the ideal operating environment are already described in the site preparation document. The environmental conditions of the machine (without media) are as follows:

Operating Temperature	15 to 32° C	59 to 90° F
Storage temperature (without water)	-10 to 70° C	14 to 158° F
Relative humidity	10 - 85 %, non-condensing	10 - 85 %, non-condensing

It is possible that the environmental conditions of the used media are stricter than those of the machine itself. Please refer to the documentation about the used media. Also, make sure that the media has had enough time to acclimatize.

2 LASER CUTTING SYSTEM COMPONENTS

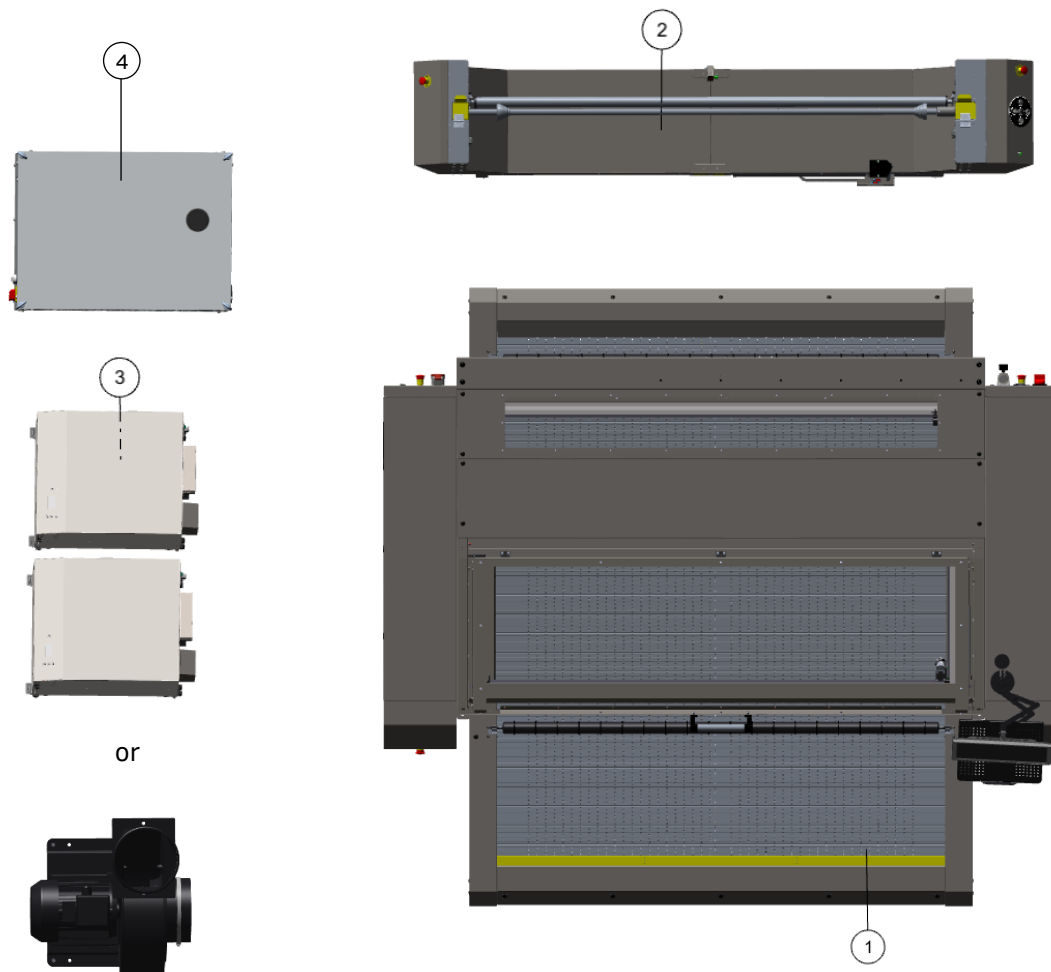

- ① Laser cutter
- ② Unwinder
- ③ Two air filtration units or one extraction fan
- ④ Water chiller (if applicable)

2.1 Laser Cutter

2.1.1 Front view

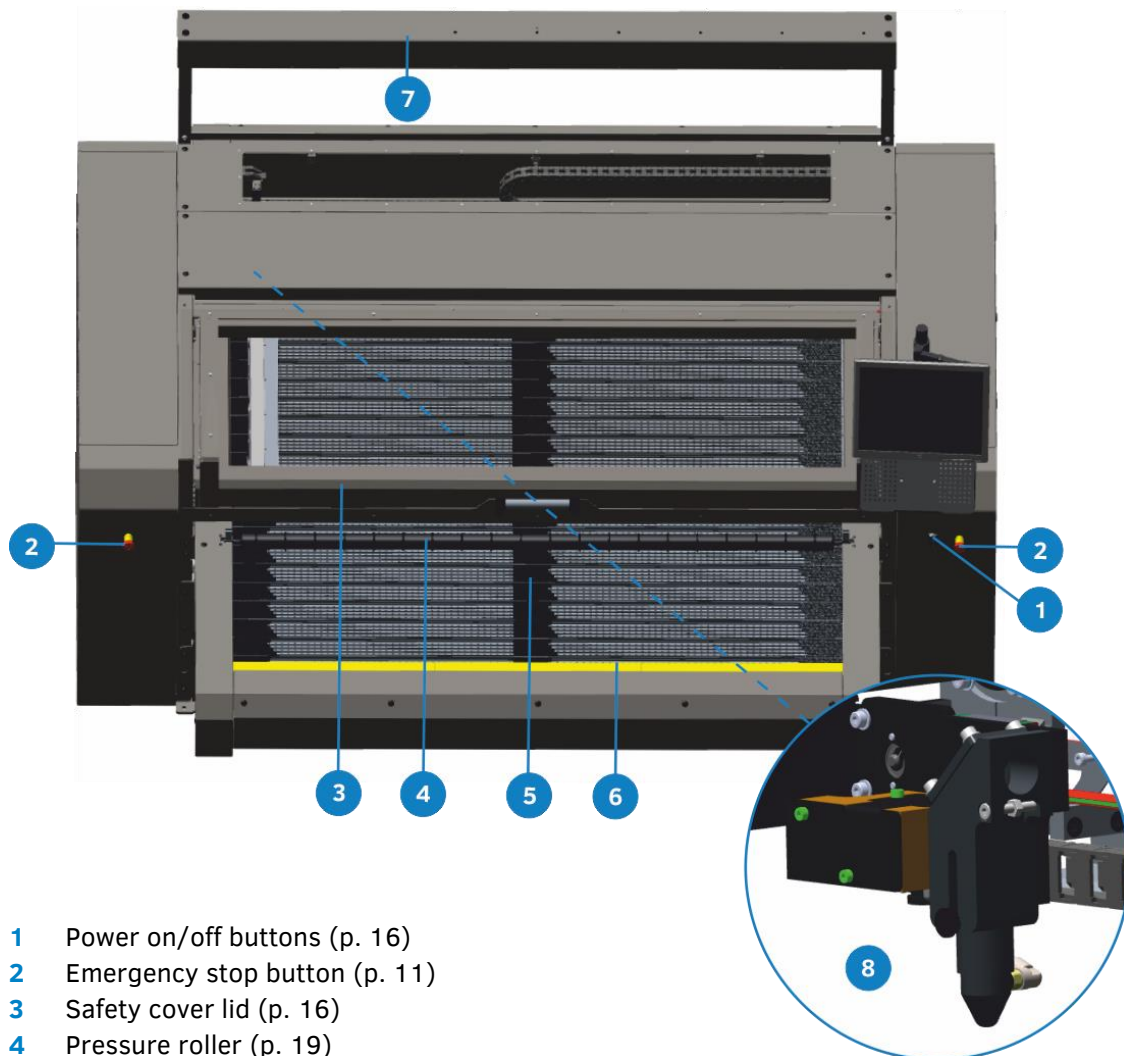

- 1 Power on/off buttons (p. 16)
- 2 Emergency stop button (p. 11)
- 3 Safety cover lid (p. 16)
- 4 Pressure roller (p. 19)
- 5 Conveyor system (p. 17) with
fume extraction/vacuum chambers underneath (p. 17)
- 6 Finger safety plates (p.16)
- 7 Vision camera gantry (p. 19)
- 8 Cutting head (p. 18) and camera (p. 19)

2.1.2 Rear view

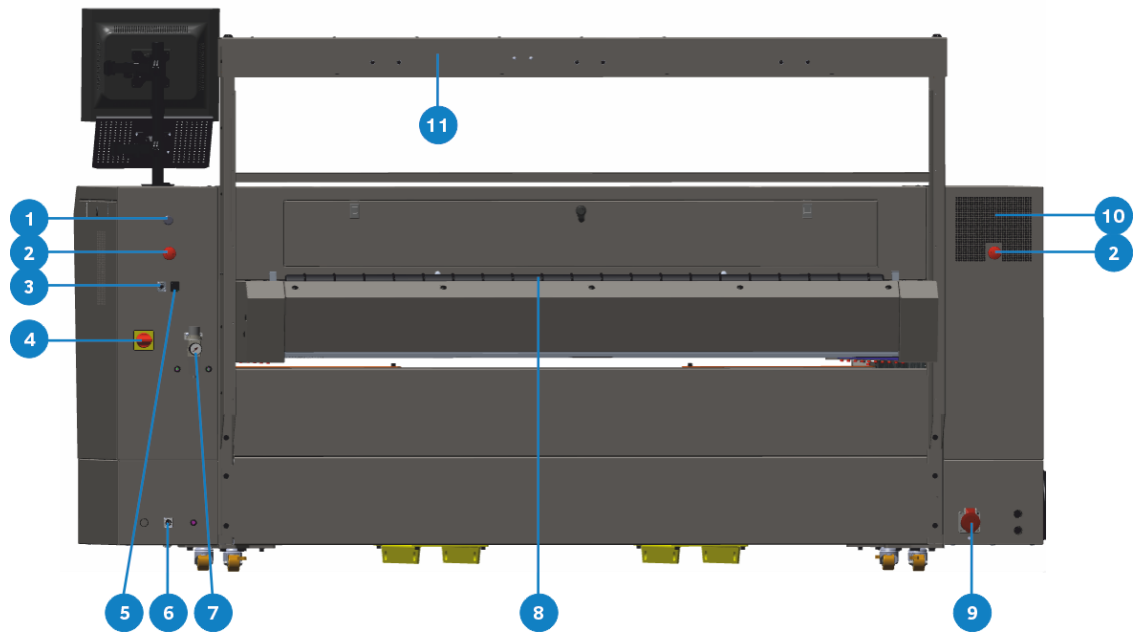

- 1 Feed button (p. 19)
- 2 Emergency stop button (p. 11)
- 3 Unwinder connection *End Of Roll* signal cable
- 4 Main power switch (p. 16)
- 5 Ethernet connection (p. 16)
- 6 Unwinder power connection
- 7 Air pressure regulator (p. 65)
- 8 Pressure roller (p. 19)
- 9 Main power plug
- 10 Air filter (p. 67)
- 11 Vision camera gantry (see p. 19)

2.1.3 Main power switch



WARNING: Pressing the OFF button will not cut all the power in the machine! Before opening any covers to perform service or maintenance, always switch off power using the main power switch.

2.1.4 ON/OFF buttons



WARNING: Pressing the OFF button will not cut all the power in the machine! Before opening any covers to perform service or maintenance, always switch off power using the main power switch.

2.1.5 Emergency stop buttons

More information can be found in chapter 1.1.5.1 *Emergency stop buttons* on page 11.

2.1.6 Ethernet connection

Inside your laser cutter is a computer with the software on it to control and send the jobs to the laser cutter. This computer has an Ethernet connection and is extended to the back of the machine.

2.1.7 Safety cover lid

More information can be found in chapter 1.1.5.2 *Safety cover lid and finger safety plates* on page 12.

2.1.8 Finger safety plates

More information can be found in chapter 1.1.5.2 *Safety cover lid and finger safety plates* on page 12.

2.1.9 Conveyor system

The conveyor system, equipped with honeycomb or blade conveyor planks, transports the material through the working area and then out of the machine. The material is held down by the vacuum/extraction system underneath the conveyor bed, resulting in a clean cut and precise material transport.



ATTENTION: Do not lean on the conveyor planks as this can cause deflection.

2.1.10 Fume extraction system

For safety and environmental reasons, fumes from around the cutting area are extracted by the extraction system underneath the conveyor bed. The laser cutter is either equipped with an extraction fan or connected to two air filtration units.

If your laser cutter is equipped with an extraction fan, please refer to *Extraction fan (optional)* on page 21 for more information.

If your laser cutter is connected to two air filtration units, please refer to *Air filtration units (optional)* on page 21 for more information.



WARNING: Before commencing any cutting procedure, ensure that the fume extraction system is in good working order and operates correctly. Some materials may produce hazardous fumes if laser cut – check with the material supplier or manufacturer before cutting. Ensure that any fumes are extracted in accordance with health and safety requirements.

2.1.11 Cutting head nozzle

The cutting head nozzle emits the laser beam that cuts the material in the cutting area.

2.1.11.1 Nozzle height

To have a clean cut a good focus of the laser beam is required. As a rule of thumb, we set the nozzle 4mm above the material. Depending on the thickness and the type of the material that is processed, height may vary.

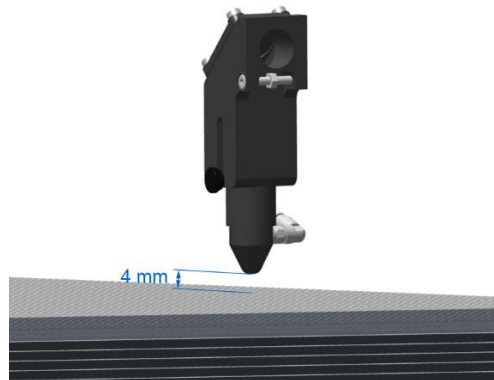

1. Loosen the thumb screw to adjust the height.

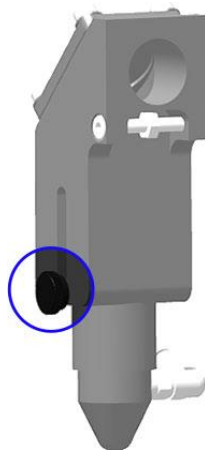

2. Place the focusing gauge between the nozzle and the material. Fix the thumb screw when the correct height is set.



2.1.12 Head camera

The laser cutter is always equipped with a head camera. The head camera supports the following advanced work methods:

- Cut-to-Frame (also known as Fixed Size cutting)
- Barcode workflow (requires Pro Pack).
- Cut-on-the-Fly

For more information on the advanced work methods, please refer to the GoProduce Laser Edition manual.

2.1.13 Pressure rollers

The pressure rollers should be placed in the lower recess to improve traction of the material on the conveyor when cutting.

2.1.14 Feed button

When this button is pressed, the conveyor will immediately advance a preset distance (see 3.1.1.3 *Configuration* on page 27) to feed the machine with material.

2.1.15 Vision camera gantry (optional)

The optional Vision camera system uses a gantry with integrated cameras to scan marks, black outlines, or barcodes, fast and accurately. It is also possible to scan, feed and cut at the same time. This camera system supports the following advanced work methods:

- Cut-to-Frame (Follow placement, follow shape or follow print)
- Barcode workflow (requires Pro Pack)
- Trace & Cut
- Cut-on-the-Fly

For more information on the advanced work methods, please refer to the GoProduce Laser Edition manual.

2.2 Unwinder (optional)

A motorised unwinder eliminates fabric distortion while cutting by securing a constant and stable fabric feed onto the cutting bed. As the roll unwinds, a loop is created to relax the material, reducing distortion, and secure an accurate cut.

The user manual of the unwinders is available for download on our website (www.summa.com/en/support/user-manuals/).

2.3 Fume extraction and vacuum system



WARNING: Before commencing any cutting procedure, ensure that the fume extraction system is in good working order and operates correctly. Some material may produce hazardous fumes if cut using the laser – check with the material supplier or manufacturer before cutting. Ensure that any fumes are extracted in accordance with health and safety requirements.

2.3.1 Air filtration units (optional)

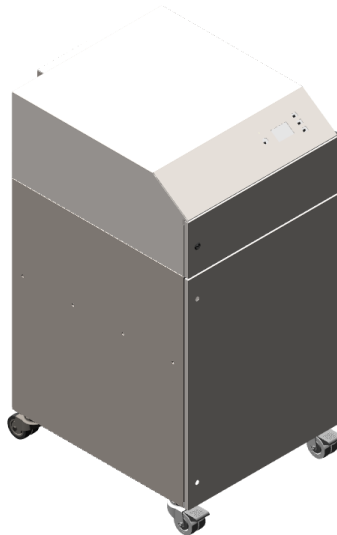

If your laser cutter is connected to two BOFA units, hazardous fumes are captured and filtered out before the clean air is recirculated back into the production environment.



NOTE: The air filtration units need to be powered on separately; they are not powered on automatically when the laser cutter is powered on.

2.3.2 Extraction fan (optional)

If your laser cutter is equipped with an extraction fan, the unfiltered air should be led outside by means of pipework.



2.4 Water chiller (optional)



NOTE: The information in this chapter only applies to the water chiller supplied by Summa. If another water chiller is used, this information is not applicable, and you should refer to the supplier's documentation of your water chiller.

2.4.1 General Description

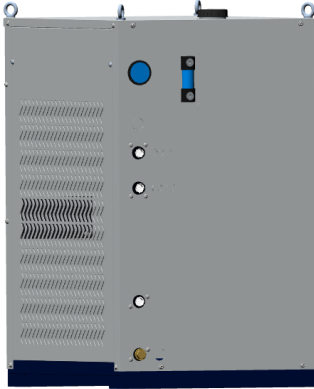

A specialised laser water chiller performs water circulation cooling on the machine's laser source and regulates its temperature to prolong its life. Summa can supply the water chiller necessary for cooling the 120W and 250W lasers.



ATTENTION: Do not cover the cooler. Always make sure that air can enter the left-side filter and exit the right side unimpeded.

ATTENTION: Make sure the bypass valve is closed during normal operation.

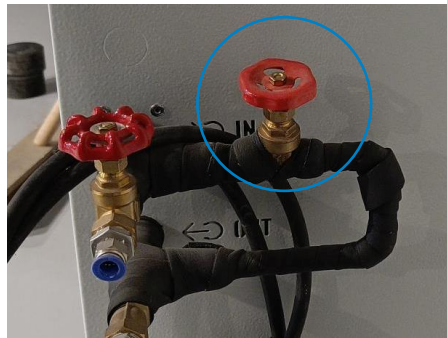

2.4.2 Temperature

The thermostat controller uses a setpoint which is the target temperature, i.e., the water temperature that is maintained in the reservoir. When the laser cutter is in operation and the cooler reservoir temperature reaches the setpoint + 2°C, the water chiller starts operating and cools the reservoir down until the temperature setpoint - 2°C is reached, after which it stops operating.

The recommended target temperature is the ambient temperature of the surroundings (this is usually around 20 °C). This setpoint is preset and should not normally be changed, but it can be by pressing the **Set** button and adjusting the temperature using the arrow keys. The normal coolant temperature ranges from 18°C to 25°C.

If the water temperature falls below the surroundings temperature, condensation will form on the pipes and on the laser tube, which can result in water dripping into the laser PSU and onto the electrical terminals inside the laser cabinet. When this happens, power off the machine immediately and check the chiller setting, wipe the affected areas dry and allow the water in the chiller to warm for 30 minutes before resuming cutting.



ATTENTION: Under no circumstances should the water temperature be allowed to reach or fall below dew point.



ATTENTION: Operating the cooler unit at temperatures lower than those specified may result in serious damage to the laser due to condensation. This type of damage is not covered by manufacturer warranty.

2.4.3 Safety precautions

The laser system is equipped with its own thermal cutoff to avoid damage to the laser, in case the operating temperature exceeds 50°C.

3 STARTING UP THE LASER CUTTER

1. Check whether maintenance tasks need to be performed. For more information, refer to chapter 4.5 *Maintenance Overview* on page 76.
2. Switch on the power supply to the laser cutter.
3. Power on the laser cutter.

The motion system moves to its home position.

If one of the covers is open, however, the motion system does not move. Instead, if GoProduce Laser edition is running, a message will appear on the computer. Follow the instruction on screen.

4. If necessary, close the cover so the motion system moves to its home position. After the motion system has fully homed, the program GoProduce Laser Edition can be used to change some settings or load the media (see following section).
5. If required, load the roll of material on the unwinder (for more information, refer to the unwinder manual).

The laser cutter is now ready to cut jobs. This is done with the GoProduce Laser Edition software program. The section below explains one tab of the program. This part of the program has nothing directly to do with sending jobs to the laser cutter, but it could be considered as a control panel to set the laser cutter up to be ready for the jobs. For more information on working with the GoProduce Laser Edition software, refer to its user manual.

3.1.1 Control panel functions in GoProduce Laser Edition

The first tab provides detailed cutter information and offers a flexible control of the cutter's configuration. Click it to reveal the options.

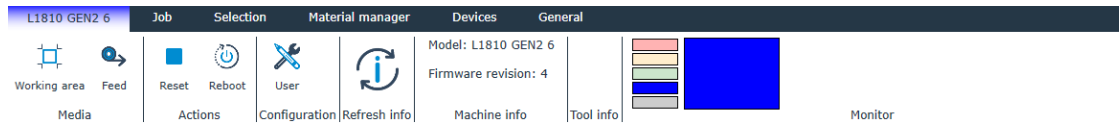

3.1.1.1 Media



Click the **Working area** icon to set the origin and size. The following window opens:

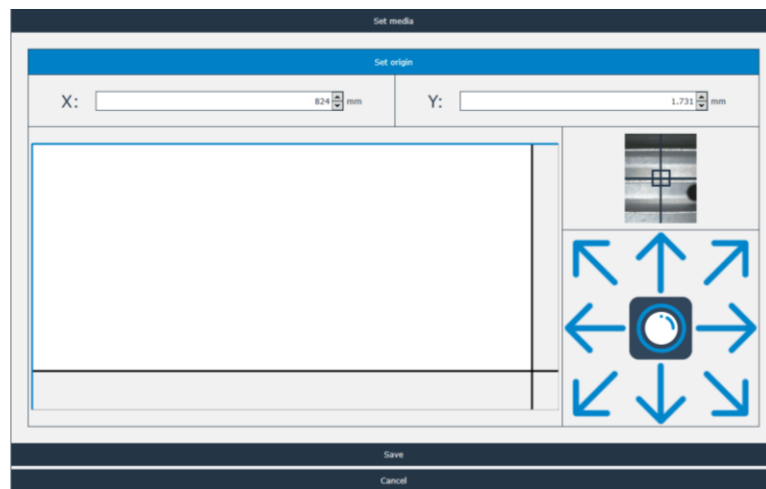

Use the camera image on screen or the laser nozzle on the machine as a reference. Click  to toggle between these two. Use the arrows, fill in the values or click in the area to set the media size. Click **Save** or **Cancel**.





Feed

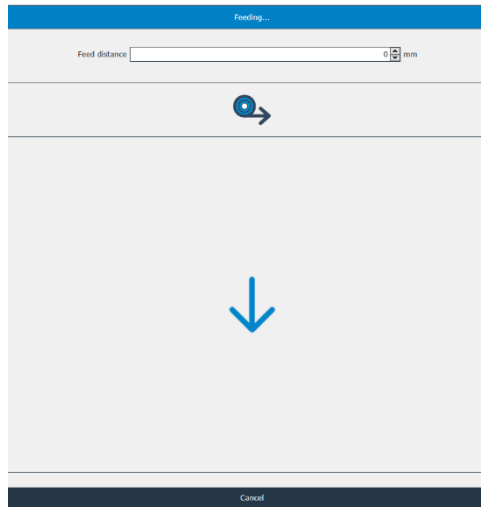



Click the **Feed** icon to open the feed media window.



Use the up and down arrows or fill in a value to set the desired feed distance,

then press  to execute, or simply click and hold  to feed continuously.

3.1.1.2 Actions

- 
 • **Reset** : for clearing the last job sent from GoProduce Laser Edition to the laser.
- 
 • **Pause** : for pausing the last job sent from GoProduce Laser Edition to the laser.
- 
 • **Reboot** : for a warm reset (similar to rebooting, without having to switch off and on).
- 
 • **Resume** : for resuming the last job sent from GoProduce Laser Edition to the laser. The resume icon appears after the pause icon is clicked.

3.1.1.3 Configuration



User

Configuration

Click **User** for setting some parameters that will be used when initiating a test or calibration routine from the program GoCare. These settings will not be used for jobs started from the program GoProduce Laser Edition. This program will overwrite them.

Parameters that can be set:

Editing device user settings.	
LASER ENABLE	OFF
FEED VELOCITY	100
LASER MIN	10
LASER MAX	100
VELOCITY	1000
FEED DISTANCE	3,000
QUALITY LEVEL	QUALITY
Save	

3.1.1.4 Info

 Refresh info	Model: L1810 GEN2 6 Serial number: L32305-10001 Firmware revision: 4	Laser type: LUXINAR SR10I Laser enable: ON
	Machine info	Tool info

The machine info field shows the laser cutter type and its revision number. The tool info field shows the laser type. If this info is not shown, click **Refresh info**.

3.1.1.5 Monitor

This section gives an idea of the status of the cutter. Sometimes a message appears to the right of the larger coloured rectangle to get the operator's attention.



Idle Mode:

The cutter is in idle mode, waiting for user input or ready to start a job.



Warning:

The operator is requested to check the status of the cutter and, if necessary, take action to resolve the issue.



Error:

An error has occurred causing the cutter to become non-operational. The error must be resolved first. Intervention is required.



In Operation:

The cutter is currently actively performing a task or operation (loading, cutting,...).

4 MAINTENANCE

This chapter explains all maintenance works that need to be performed on the laser cutting system. A complete overview can be found in chapter 4.5 *Maintenance Overview* on page 76.



WARNING: Before performing any maintenance, disconnect the laser cutter from the main power supply.

4.1 Laser cutter

There are no user-serviceable parts inside the laser cutter. For servicing, refer to qualified personnel only. Turn off the machine and contact a service representative in any of the following cases:

- There is visible mechanical damage.
- The power cord is damaged.
- The machine (or parts of it) has (have) been damaged.
- Liquid was spilt on the machine or conveyor.
- There is a strange noise, smoke or an unusual smell coming from the machine.

Keep the laser cutter as clean as possible. When necessary, clean outside panels of the unit with a soft damp cloth.



WARNING: Do not use abrasives or solvent-based cleaners on the polycarbonate safety cover.



WARNING: If liquid-based cleaners have been used, ensure that the units are completely dry before switching on.

The maintenance and cleaning tasks are listed in the maintenance overview (p. 76), with the allowed time intervals between checks. However, the laser cutter should be checked thoroughly every time it is used, so that minor faults can be corrected without serious damage occurring.

4.1.1 Laser beam alignment

The program GoCare is used for laser beam alignment. This program has a wizard that explains in detail the steps that need to be followed to align the laser beam. The wizard will guide you through the process of calibrating the machine components to (re)align the laser beam. As a reference the procedure is written out below.

**Caution**

Class 1 Laser Product.

Class 4 invisible laser radiation when open.

Avoid eye or skin exposure to direct or scattered radiation.

It is ALWAYS, also including during this calibration process, prohibited to adapt, disable or override the safety systems of the machine. When the machine is misused or when the safety systems are not functioning as defined by the manufacturer, Summa cannot be held accountable for any mechanical damage or injuries caused.

4.1.1.1 Required tools and parts

- Universal cross key
- Level (about 20 to 30 cm long)
- Hex key set
- Hex bit #5
- Roll of paper tape
- Alignment kit 600-6133
 - Target holder
 - Nozzle target holder
 - Targets
- Laser safety goggles (provided with the machine or available for purchase)

4.1.1.2 Preparation

4.1.1.2.1 Covers

1. Open the polycarbonate lid.

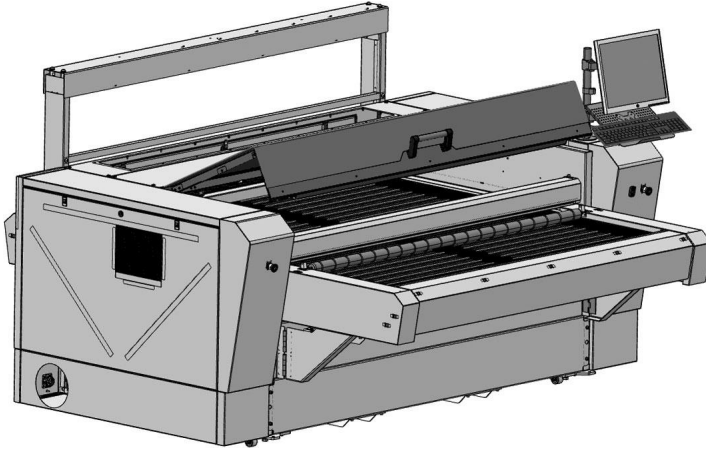

2. Remove the two screws on the bottom of the front hinge and open the cover.

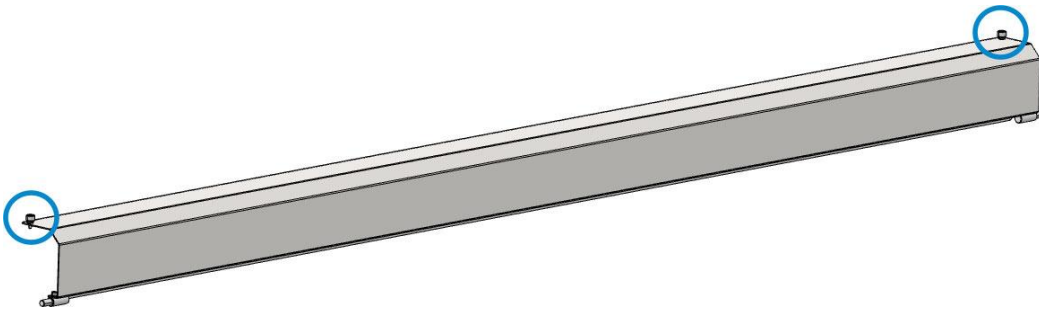

3. Use the universal cross key to unlock (do not remove) the left panel.

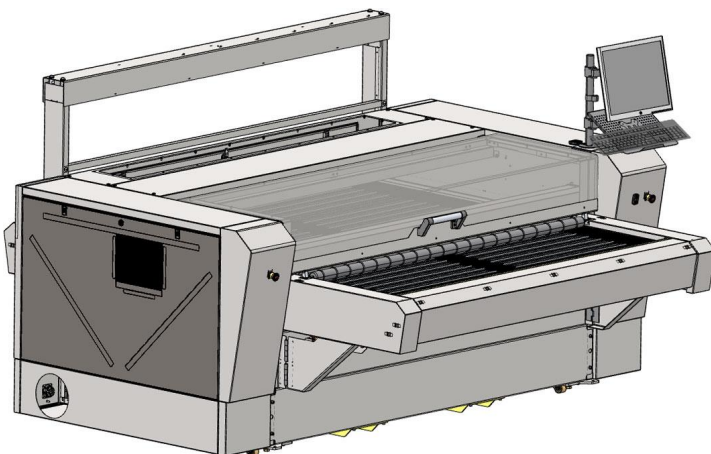

4.1.1.2.2 Start alignment procedure

Spot mode allows you to fire the laser manually for a set amount of time with a set percentage of power. It will be frequently used throughout the calibration process.

Use the program GoCare to do this.

1. Start the program Summa GoCare.

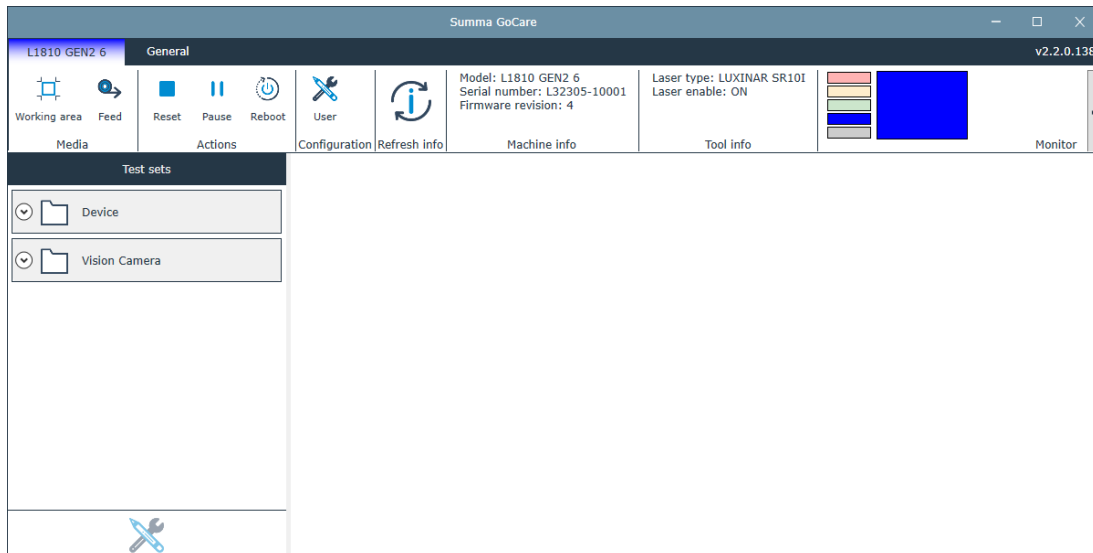

If the model and laser type are not showing, click **Refresh info**. Only when the model and laser type are displayed, it is certain that the program can control the laser cutter.

2. In the test sets section, click **Device** > **Device – Laser alignment**.

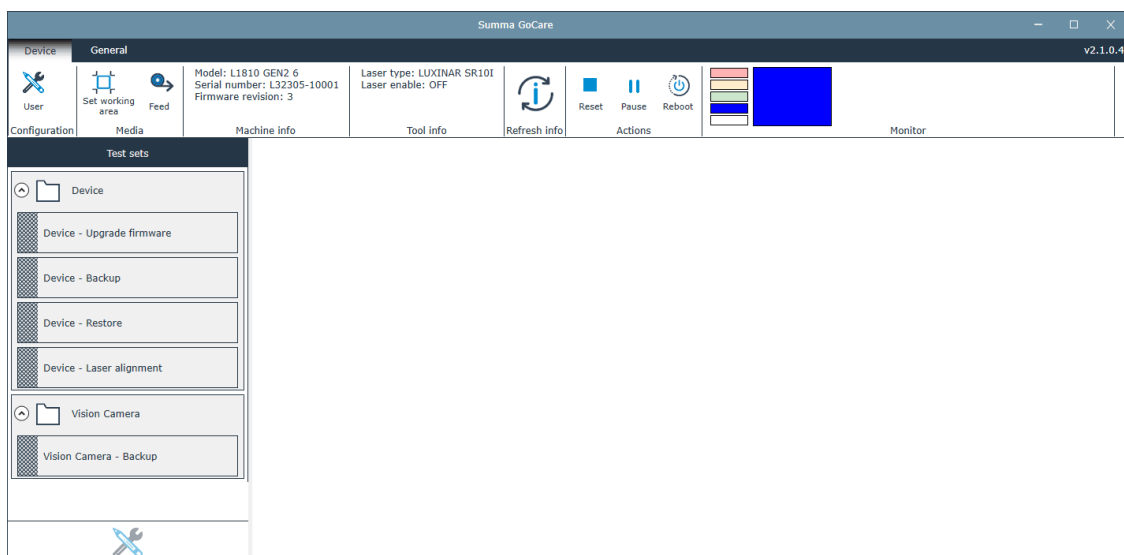

3. Follow the wizard to align the laser.

The following section describes in detail the alignment of the laser.



NOTE: Frequently replace the targets to avoid igniting the target and confusion while calibrating.

4.1.1.3 Laser alignment

The purpose of this adjustment is to get the laser beam to hit the material properly at any position. Poorly aligned lasers can cause a less powerful output at the nozzle, damage, or harm to the operator due to unpredictable reflections.

4.1.1.3.1 Components

Some of the illustrations do not represent the actual components or actions. They are used for demonstration purposes only.

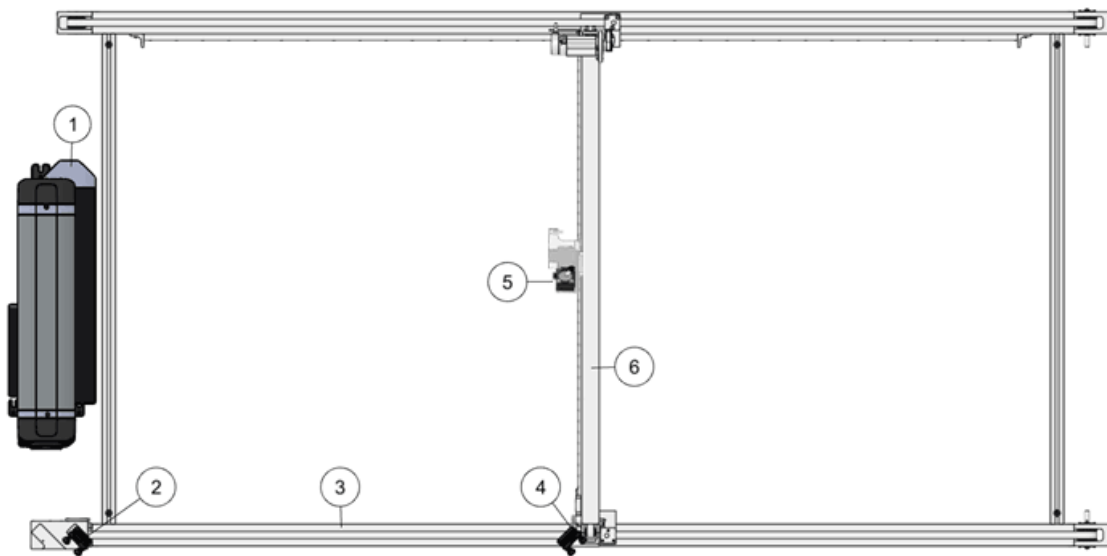

- ① Laser unit
- ② Primary mirror
- ③ Front axis
- ④ Secondary mirror
- ⑤ Cutting head mirror (third mirror)
- ⑥ Top beam axis

4.1.1.3.2 Check corners

Start by checking if the laser hits the target in the centre in all four corners of the working area.

1. Put the target holder with a target in the cutting head opening.

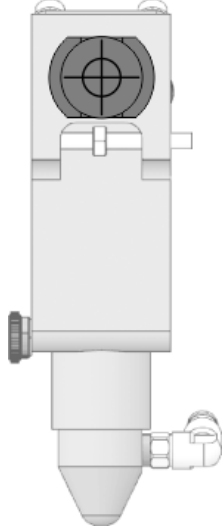

2. Use spot mode to fire the laser in the order pictured below. If necessary, use a new target to determine the position of the laser correctly in every corner.

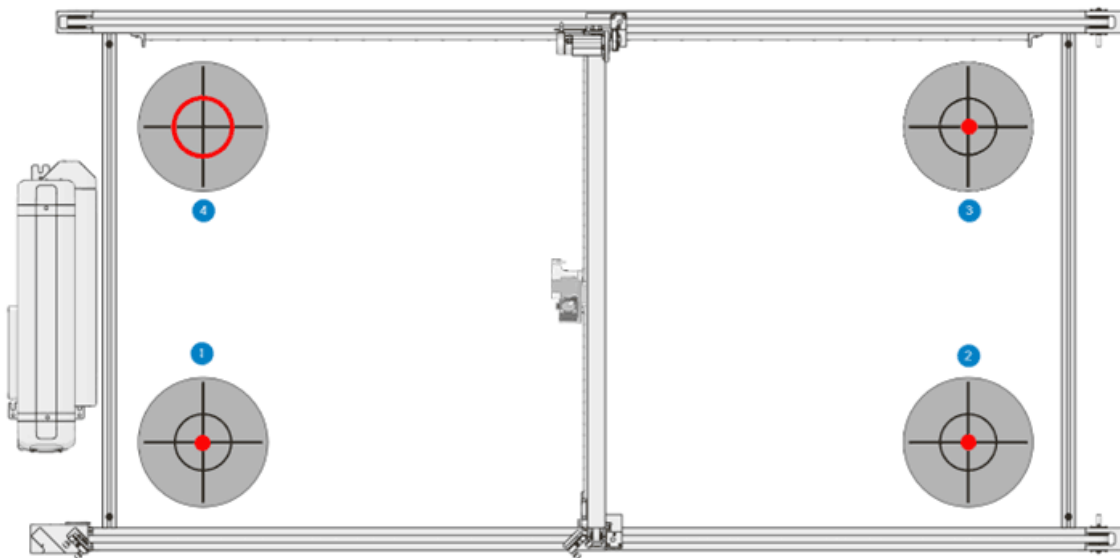

3. The results should match the following specifications:

Target No	Position	Result
1	Front left	Mark centred on target
2	Front right	Mark centred on target
3	Back right	Mark centred on target
4	Back left	Mark within red circle

Marks within specification	Marks NOT within specification
Continue to chapter 4.1.1.3.5 <i>Third (45° angled) mirror</i> on page 48.	Continue to chapter 4.1.1.3.2.1 <i>Possible causes</i> on page 35.

4.1.1.3.2.1 Possible causes

When the result does **not** match the specifications, depending on the case, some mirror calibrations will need to be performed again. **NOTE:** The examples below are theoretical examples for demonstration purposes. The actual results can vary due to mechanical tolerances.

CASE 1: There are no marks on the targets. **Contact your Summa dealer for further technical support.**

CASE 2: There is only a mark on target 1. Continue to chapter 4.1.1.3.3.1 *Check beam path* on page 39.

CASE 3: The marks on targets 1 and 2 are not in the same place. This means that the beam is angled between those targets. Continue to chapter 4.1.1.3.3.2 *Laser beam parallel with front axis* on page 41.

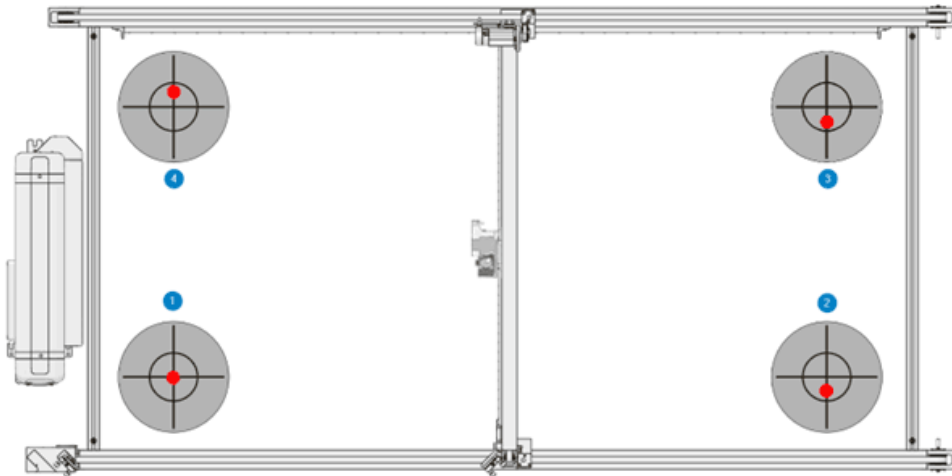

CASE 4: The marks on targets 1, 2, and 3 are in the same place but not centred. This means that the laser module or primary mirror slide probably moved. **Contact your Summa dealer for further technical support.**

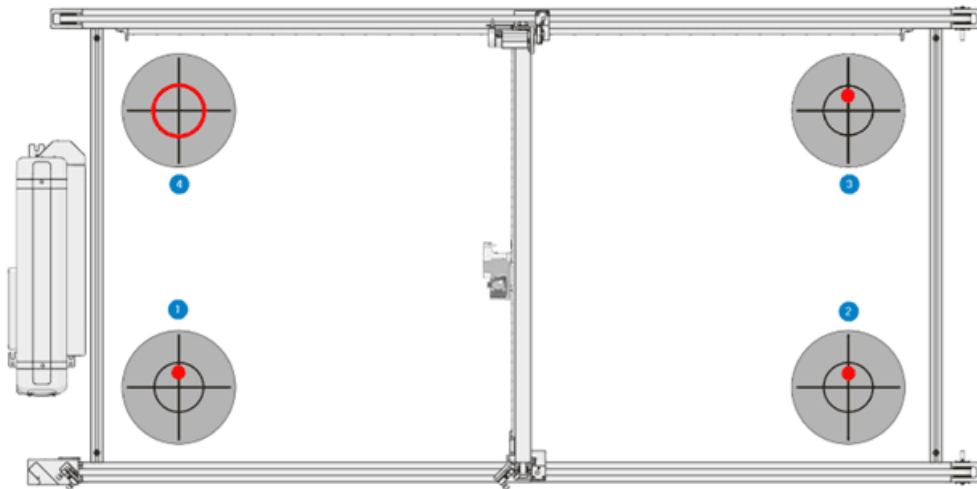

CASE 5: The marks on targets 1 and 2 are in the same place, while the marks on targets 3 and 4 are lower or higher than that. Continue to chapter 4.1.1.3.4.2 *Laser parallel with top beam axis* on page 46.

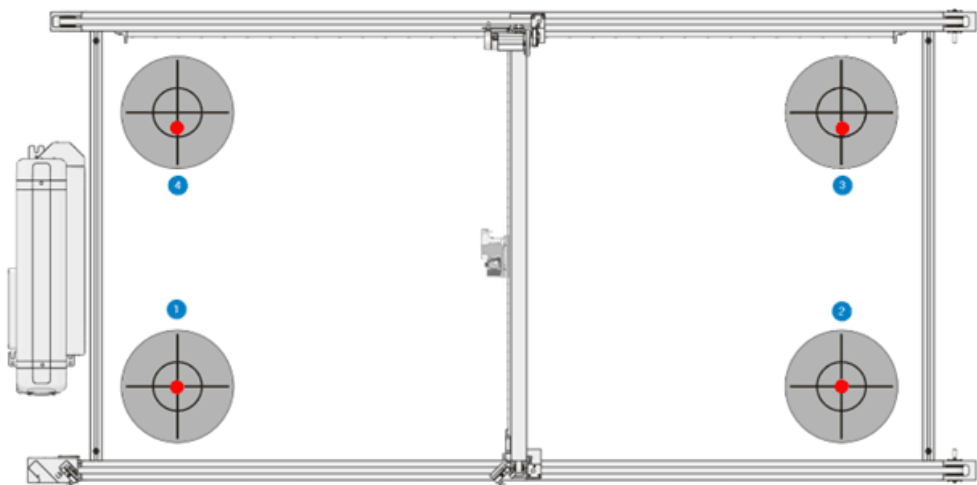

CASE 6: The marks on targets 1 and 2 are centred, but the marks on targets 3 and 4 do not meet the specifications. Follow the procedure from chapter 4.1.1.3.4.2 *Laser parallel with top beam axis* on page 46 and use the specifications below.

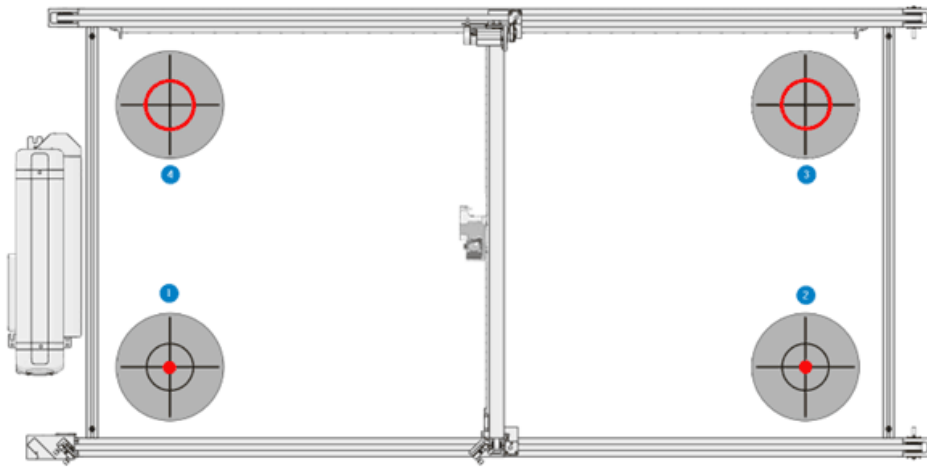

Target No	Position	Result
1	Front left	Mark centred on target
2	Front right	Mark centred on target
3	Back right	Mark within red circle
4	Back left	Mark within red circle

4.1.1.3.3 Primary mirror calibration

The primary mirror is the first component that reflects the laser beam. It is in front of the laser unit.

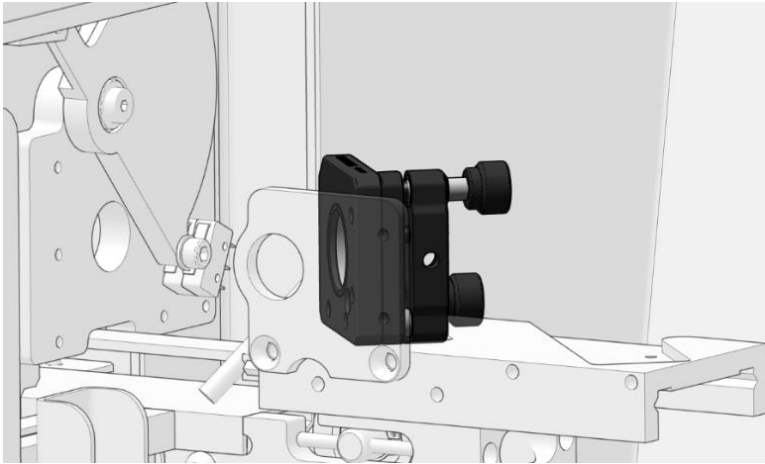

The primary mirror changes the **angle** (not the height!) of the laser beam. The angle can be adjusted by means of the thumbscrews on the mirror holder (① and ②). The locknut ③ is used to fix the thumbscrews in place. The bolt ④ is used to fix the whole bracket in place. Prior to any adjustment, ③ and ④ need to be loosened.

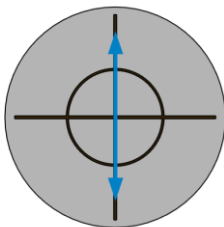
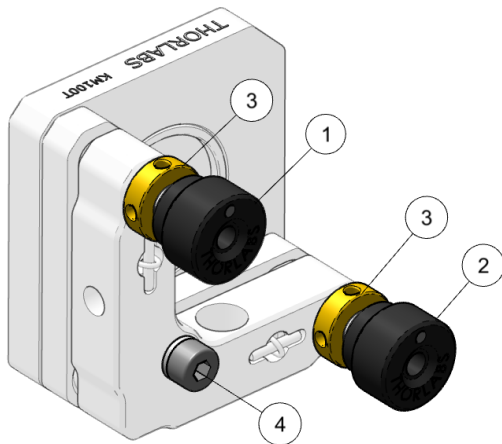

①: Up and down

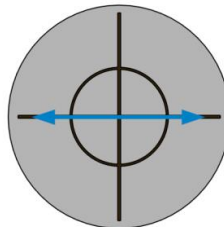

②: Left and right

4.1.1.3.3.1 Check beam path

This calibration ensures that the laser hits the secondary mirror on the far left and right of the machine.

1. (Re)place a target in the cutting head.

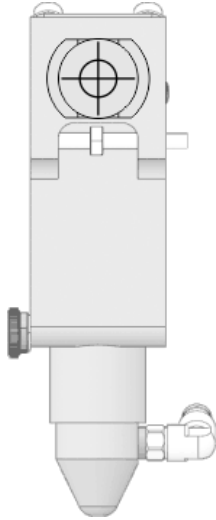

2. Use spot mode to move the head all the way to the front left side and fire the laser.

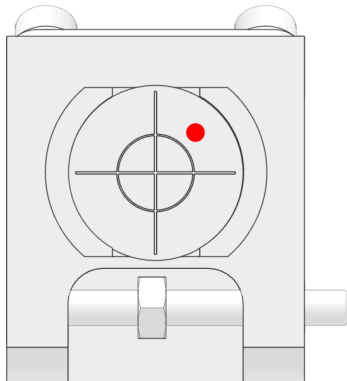

3. Move the cutting head about 25cm to the right.
4. Fire the laser.

Mark on target	No mark on paper tape
Return to step 3. If you reach the right end (origin), continue to chapter 4.1.1.3.3.2 <i>Laser beam parallel with front axis</i> on page 41.	Continue to step 5.

5. Move the head 10cm to the left and fire the laser again.
6. Open the left side cover.

7. Unscrew the locknuts ③ and bolt ④ to adjust the thumbscrews on the primary mirror to shoot as close as possible to the previous mark.

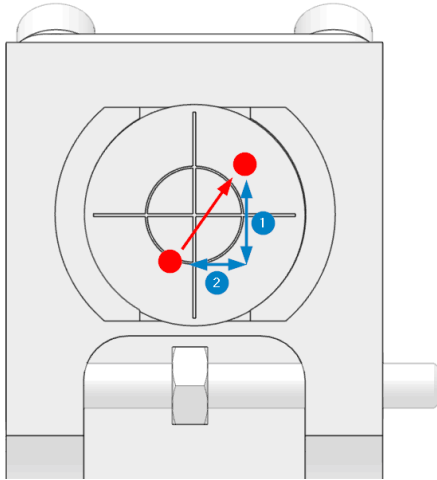

- ①: Up and down ②: Left and right

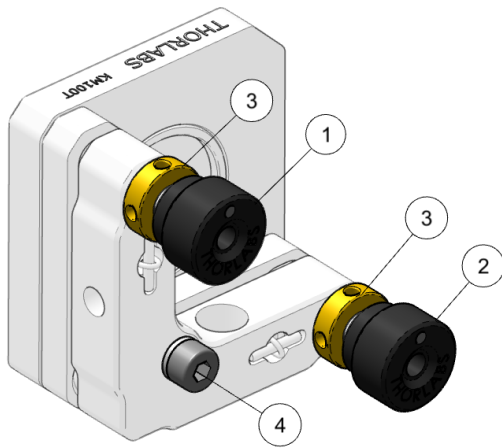

8. Resecure the locknuts ③, bolt ④, close the left side cover and return to step 4.

4.1.1.3.3.2 Laser beam parallel with front axis

The purpose of this calibration is to align the laser parallel to the front axis. This ensures that the laser beam always hits the secondary mirror at the same spot, regardless of where it is positioned along the front axis.

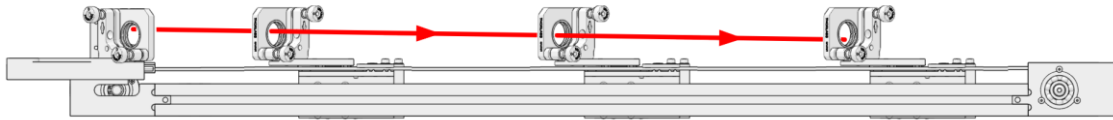

Beam path goes down = **NOK**

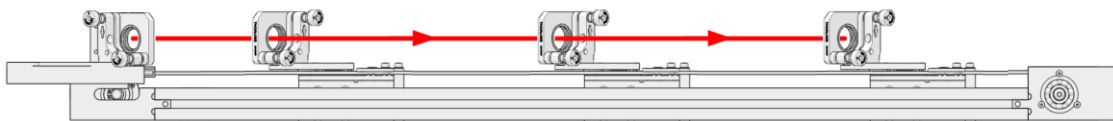

Beam path runs parallel with front axis = **OK**

1. (Re)place a target in the cutting head.

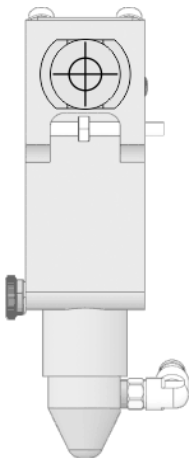

2. Use spot mode to move the head all the way to the front left side and fire the laser.

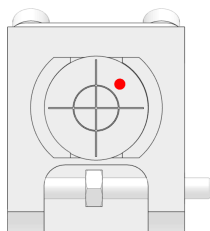

3. Move the head all the way to the front right side and fire the laser again.

Marks are on top of each other	Marks are NOT on top of each other
Continue to chapter 4.1.1.3.4 <i>Secondary mirror</i> on page 43.	Continue to step 4.

4. Open the left side cover.
5. Unscrew the locknuts ③ and bolt ④ to adjust the primary mirror so that the second mark is exactly on top of the previous mark.

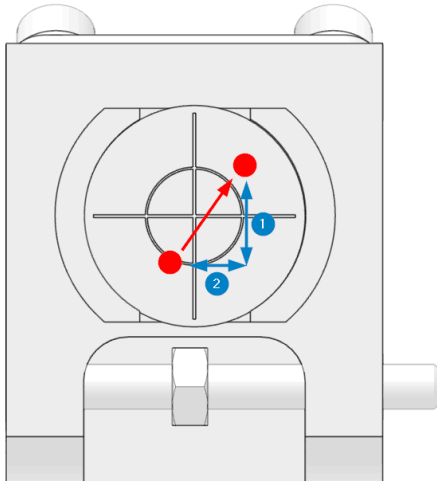

- ①: Up and down ②: Left and right

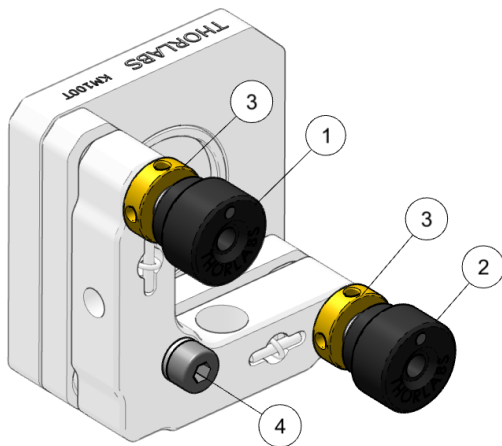

6. Tighten the locknuts ③, bolt ④, close the left side cover and return to step 1.

4.1.1.3.4 Secondary mirror

The secondary mirror is mounted on the top beam. It moves along with the top beam and reflects the laser beam to the cutting head.

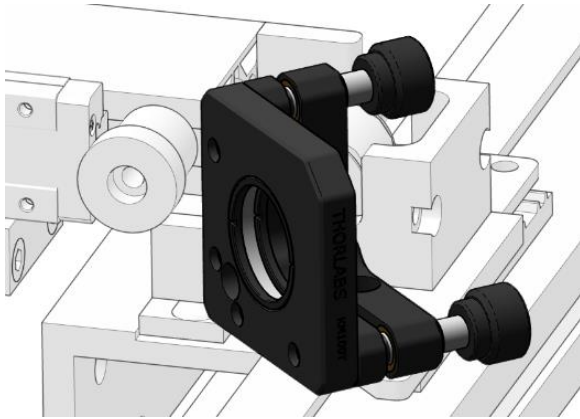

Adjusting the mirror holder can be done by means of the thumbscrews (① and ②). The locknut ③ is used to fix the thumbscrews in place and the bolt ④ is used to fix the whole mirror bracket in place.

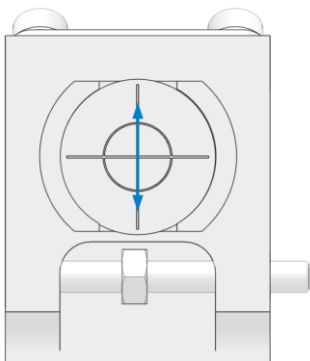
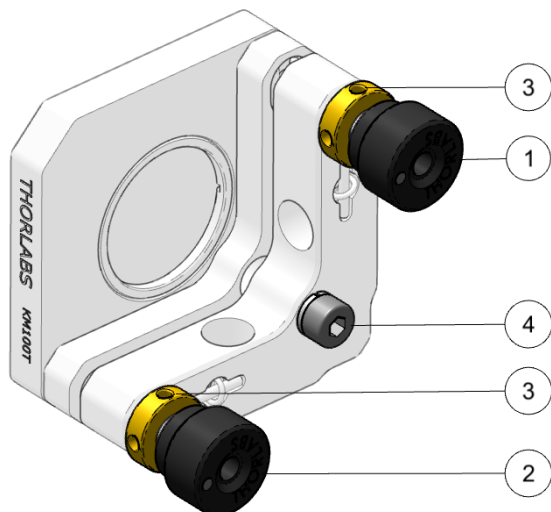

①: Up and down

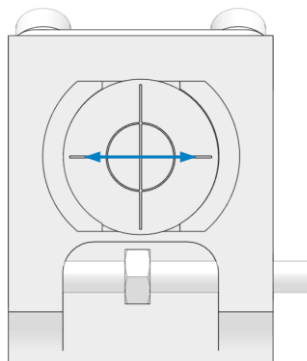

②: Left and right

4.1.1.3.4.1 Check beam path

This calibration ensures that the laser hits the (45° angled) third mirror in the cutting head when it is positioned in the front and back of the top beam.

1. Put the target holder with a target in the cutting head opening.

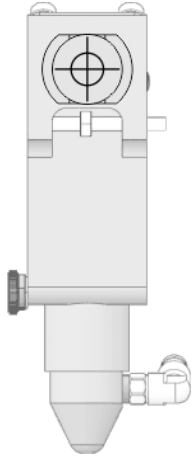

2. Use spot mode to fire the laser when the head is at its origin position (front right).

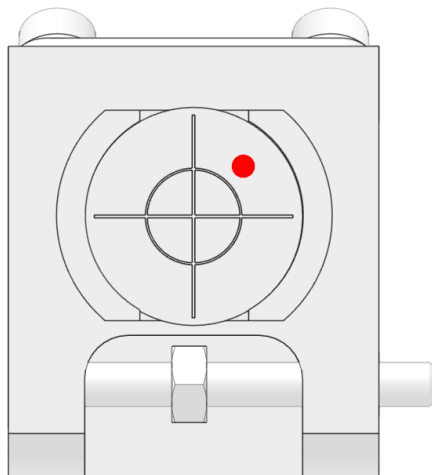

3. Move the head 25cm to the back.
4. Fire the laser.

Mark on target	No mark on target
Return to step 3. If you reach the back end, continue to chapter 4.1.1.3.4.2 <i>Laser parallel with top beam axis</i> on page 46.	Return the head 10cm to the front and continue to the next step.

5. Fire the laser.
6. Unscrew the locknuts ③ and bolt ④ to adjust the secondary mirror to shoot as close as possible to first mark.



①: Up and down ②: Left and right

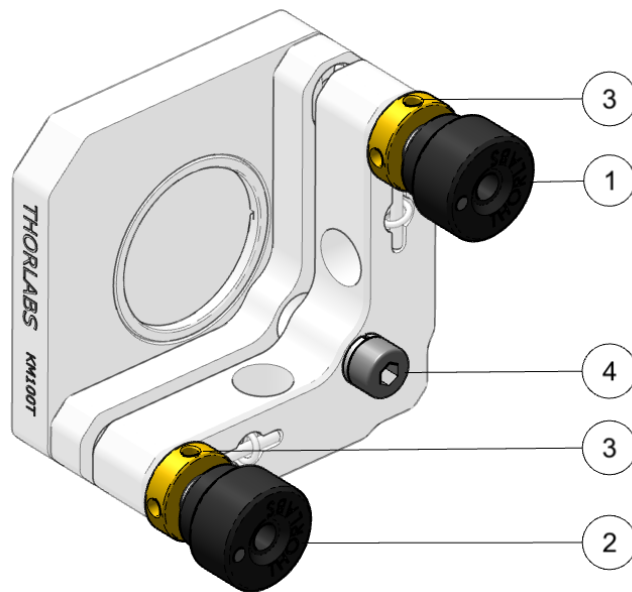

7. Return to step 4.

4.1.1.3.4.2 Laser parallel with top beam axis

Like the previous calibration, this will align the laser parallel to the top beam axis. This ensures that the laser beam always hits the (45° angled) third mirror at the same spot, regardless of where it is positioned along the top beam axis.

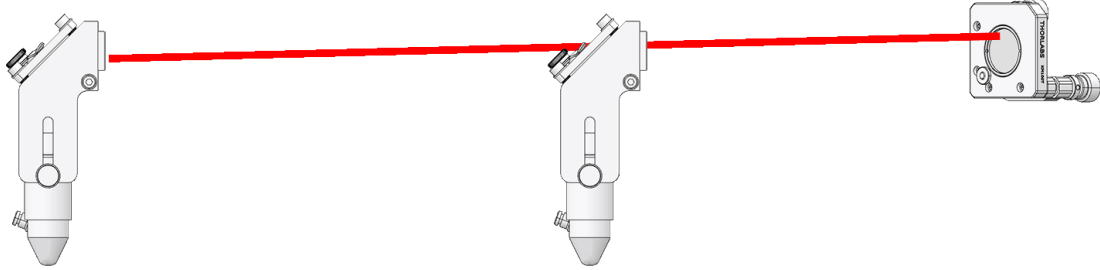

Beam path goes down = **NOK**

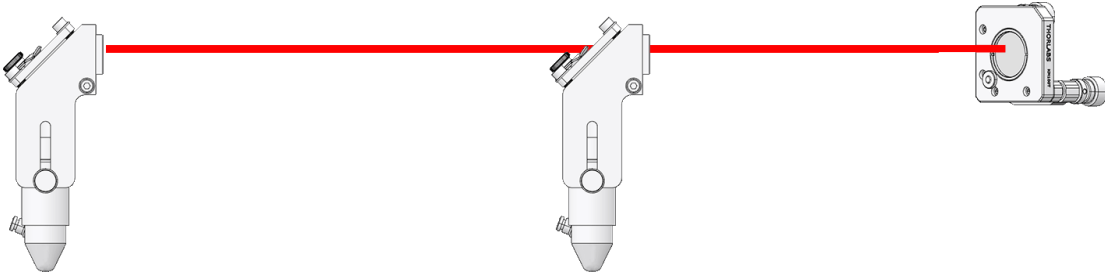

Beam path goes parallel with the top beam axis = **OK**

1. (Re)place the target.
2. Use spot mode and fire the laser in the front right position (origin).

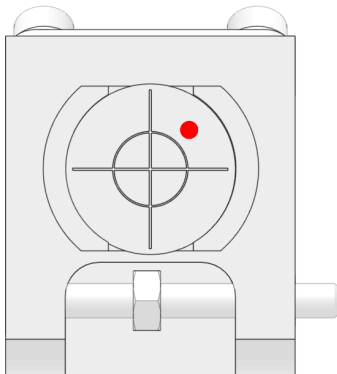

3. Move the head all the way to the back and fire the laser.

Marks are on top of each other	Marks NOT on top of each other
Continue to chapter 4.1.1.3.5 <i>Third (45° angled) mirror</i> on page 48.	Continue to step 4.

4. Unscrew the locknuts ③ and bolt ④ to adjust the secondary mirror so that the second mark is **exactly** on top of the first mark.

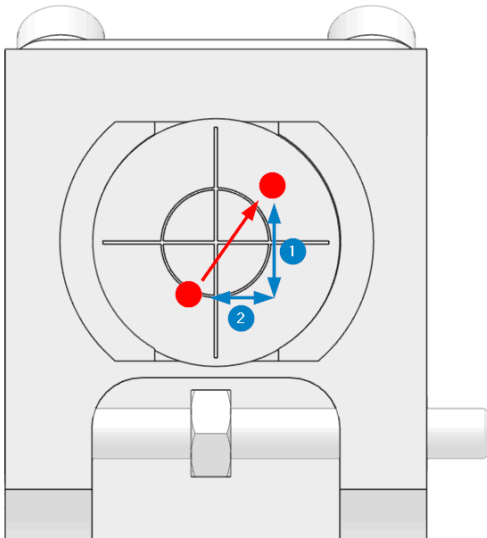

①: Up and down

②: Left and right

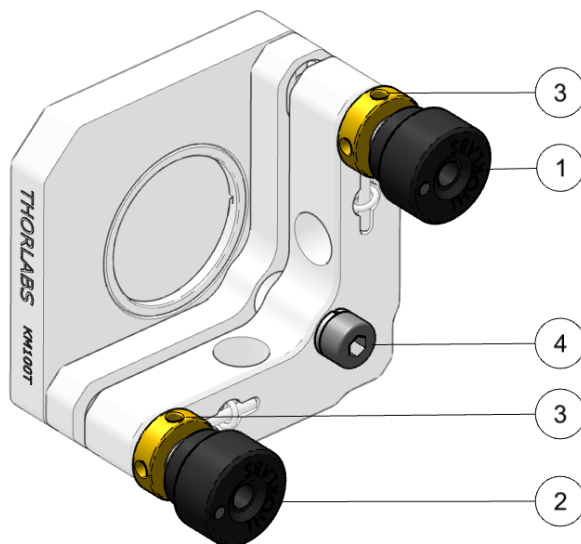

5. Return to step 1.

4.1.1.3.5 Third (45° angled) mirror

This is the last mirror in the beam path and guides the laser beam through the centre opening of the nozzle.

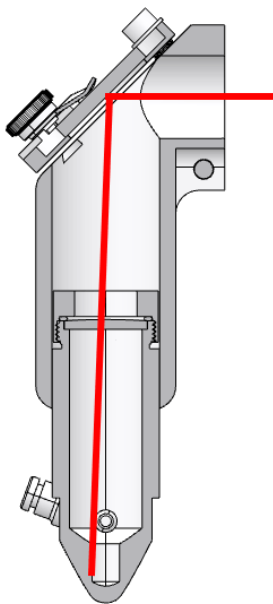
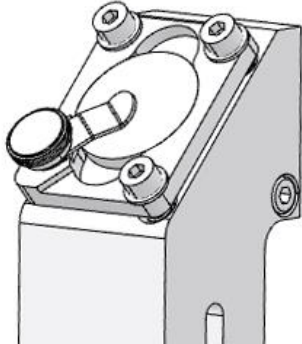

NOK

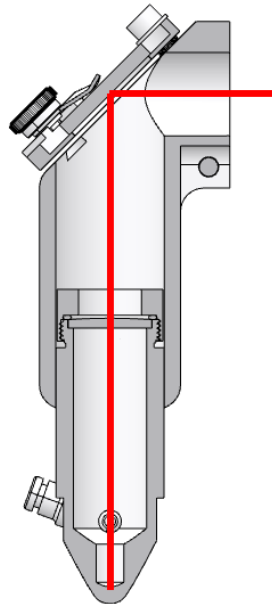

OK

4.1.1.3.5.1 Centring laser beam through nozzle

1. Use the thumbscrew to raise the nozzle as high as possible.

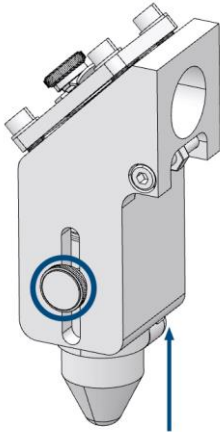

2. Mount the nozzle target holder on the bottom of the nozzle.

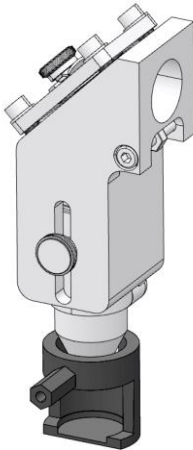

3. (Re)place the target.

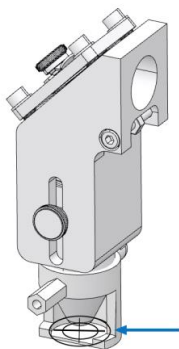

4. Use spot mode to fire the laser.

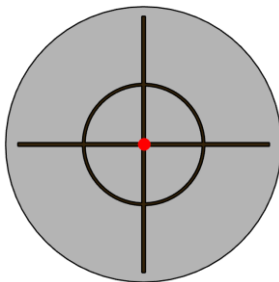

OK

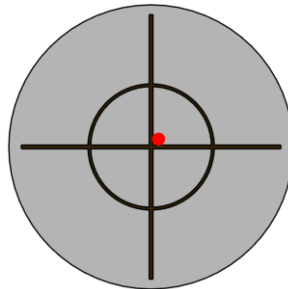

NOK

Mark perfectly centred on target	Mark NOT centred on target
Continue to chapter 4.1.1.3.6 <i>Final corners check</i> on page 51.	Continue to step 5.

5. Use the hex screws to centre the mark on the target.

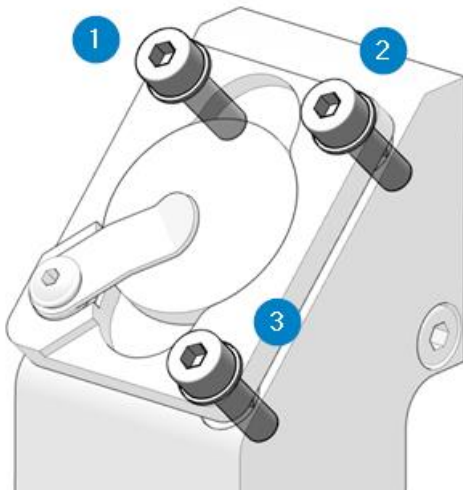

① and ②= up and down

② and ③= left and right

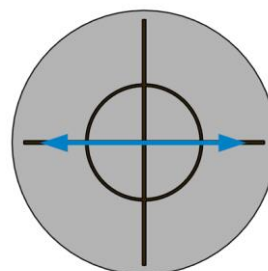
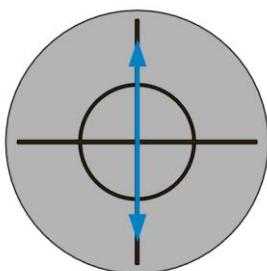

6. Return to step 3.

4.1.1.3.6 Final corners check

After the above calibrations have been performed, the laser beam should hit the target as specified below.

1. Put the target holder with a target in the cutting head opening.

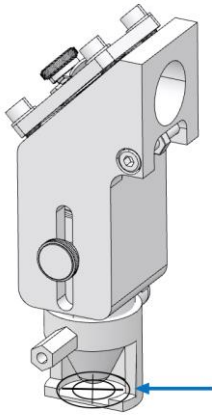

2. Use spot mode to fire the laser in the order pictured below.

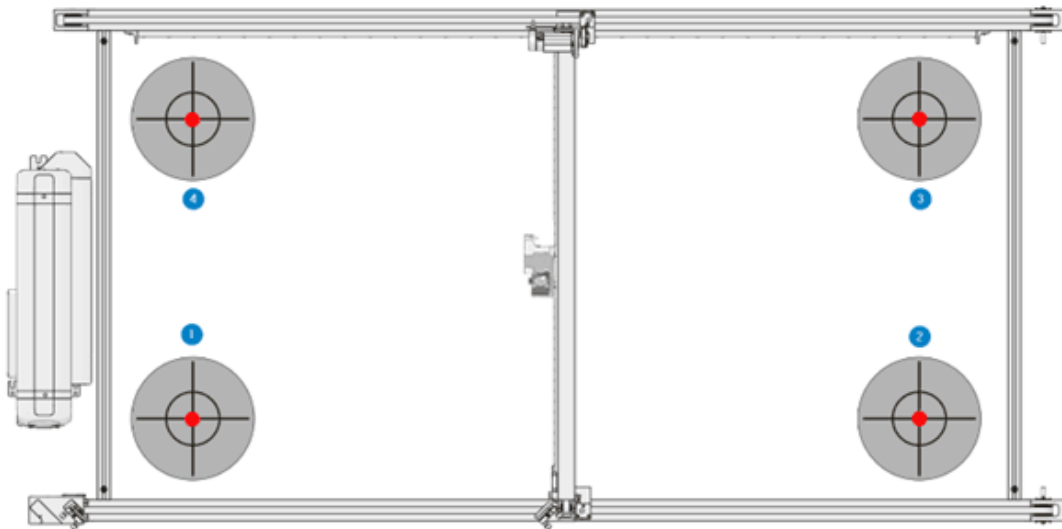

3. The results should match the specifications below.

Target No	Position	Result
1	Front left	Mark centred on target
2	Front right	Mark centred on target
3	Back right	Mark centred on target
4	Back left	Mark centred on target

Marks within specification	Marks NOT within specification
Remove the nozzle target holder. The laser alignment is finished.	Return to chapter 4.1.1.3.5 <i>Third (45° angled) mirror</i> on page 48.

4.1.2 Optical components

To achieve maximal power output from the laser cutter, the system's optical components must be in good working order. Poorly cleaned optics absorb more heat and are more likely to burn or shatter!

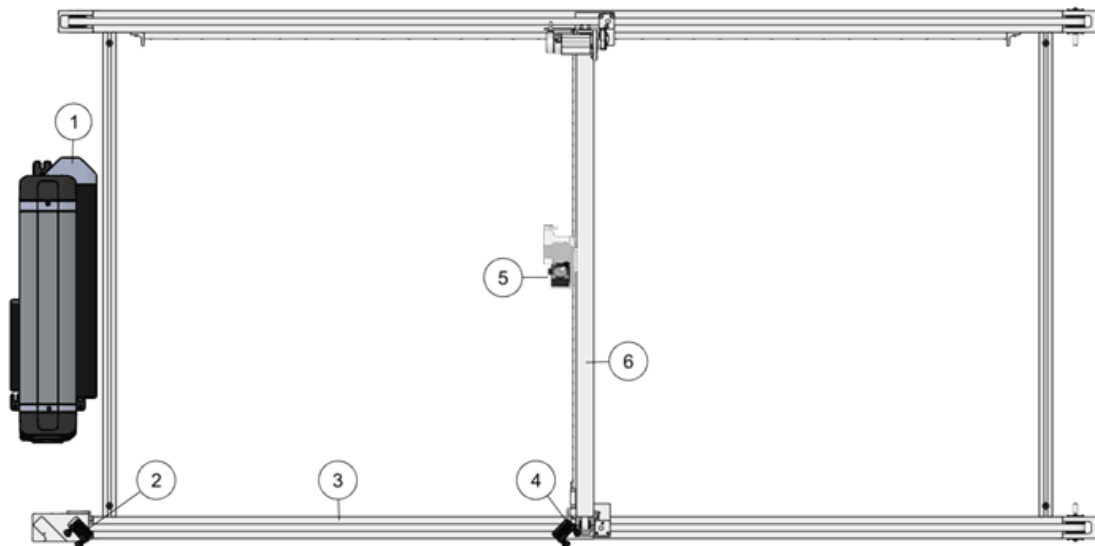

- ① Laser unit
- ② Primary mirror
- ③ Front axis
- ④ Secondary mirror
- ⑤ Third mirror and lens in cutting head
- ⑥ Top beam axis

The optical components must be handled with care and cleaned only with optical cleaning solution and an optical grade polishing cloth. They must not be subjected to abrasives, etc. The working surfaces must not be handled directly. Ideally, gloves or finger cots should be used to avoid fingerprints on the surfaces. Optical cleaning equipment is supplied in the tool kit and further supplies may be obtained from the distributor.

- 1 Gloves
- 2 IPA cleaning solution
- 3 2.5mm hexagonal hex key
- 4 4mm hexagonal hex key
- 5 Lens-cleaning cloth (lint-free)



4.1.2.1 Cleaning the primary mirror

1. Remove the left-hand side cover of the laser cutter using a control cabinet key to gain access to the primary mirror.

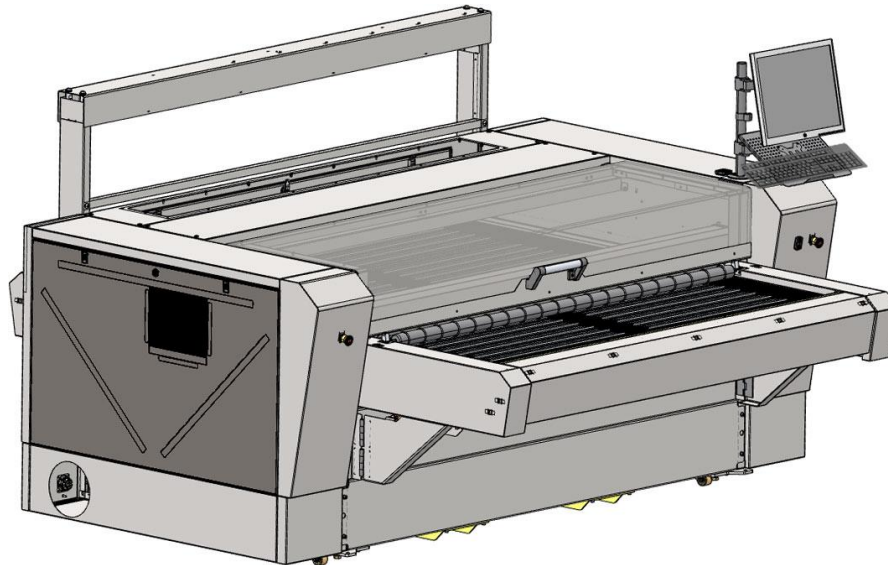

2. It is important to touch the mirror as little as possible. Use the air blower to remove any debris from the mirror while the mirror remains in its position.



3. If this does not remove all the debris, dust the mirror with the soft brush.



4. If this still does not remove all the debris, only then apply a small amount of IPA optical cleaning solution onto the cleaning cloth provided in the tool kit and clean the mirror while the mirror remains in its position. Do not adjust the mirror position and do not apply too much pressure to the mirror; the bracket must not move out of alignment.

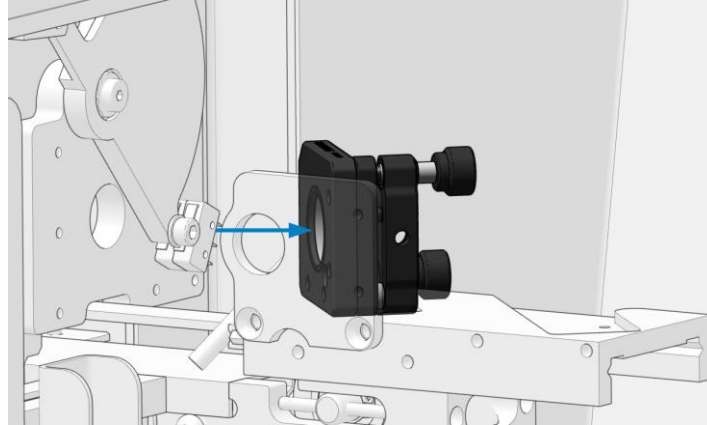

NOTE: If the primary mirror needs to be recalibrated (e.g. when it is misaligned due to cleaning), please refer to 4.1.1.3.3 *Primary mirror calibration* on p. 38.

4.1.2.2 Cleaning the secondary mirror

1. Open the safety cover lid.

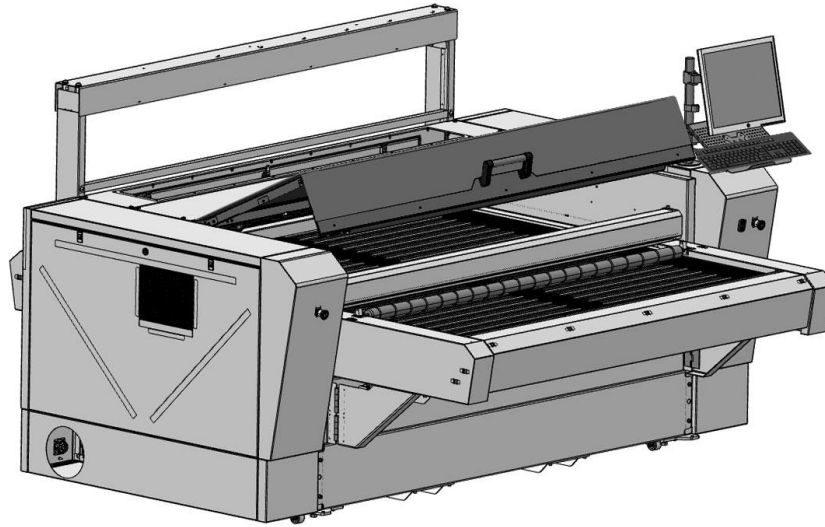

2. Remove the two bottom screws of the front guard and open it.

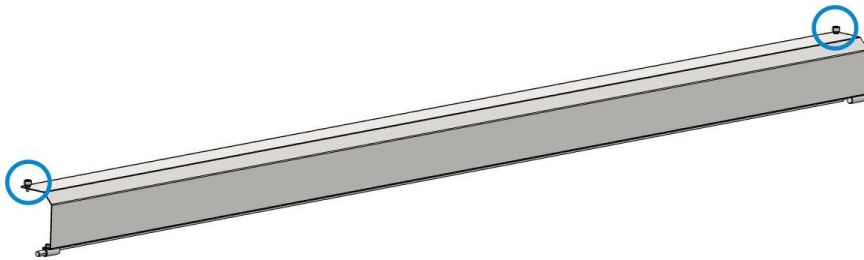

3. Apply a small amount of IPA optical cleaning solution onto the cleaning cloth provided in the tool kit and clean the mirror while in position. Do not adjust the mirror position and do not apply too much pressure to the mirror; the bracket must not move out of alignment.

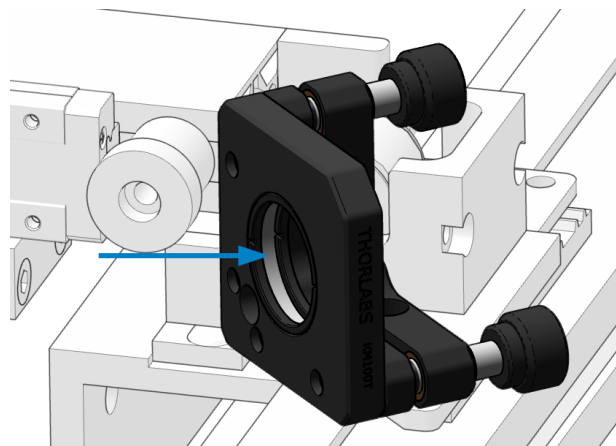

4.1.2.3 (Un)Installing the static and travelling mirrors

For removing the static and travelling mirrors from their mount (e.g., in the event of a defect) and installing them again, use the spanner wrench (delivered in the toolbox).

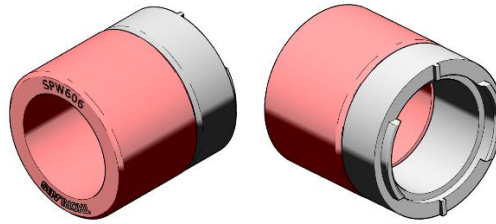

4.1.2.3.1 Removing the mirror

1. Place the spanner wrench on the mirror retaining washer so that the notches fit together.

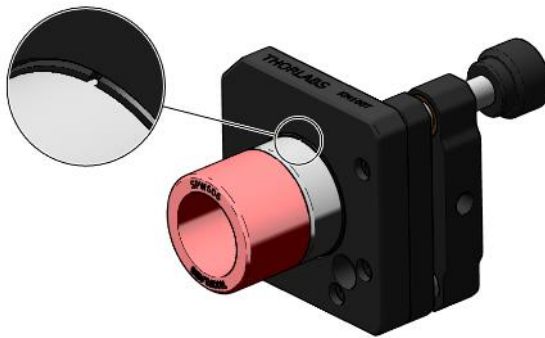

2. Turn the wrench to loosen the washer and take it out. The mirror is now loose.
5. Gently remove the mirror.

4.1.2.3.2 Installing the mirror

1. Wearing gloves or finger cots to avoid fingerprints on the surface, gently place the mirror in the mirror mount.
2. Place the mirror retaining washer on the spanner wrench so that the notches fit together.
3. Place the spanner wrench against the mirror mount and turn the wrench to secure the mirror.

4.1.2.4 Cleaning the cutting head lens

The cutting head lens coating is fragile; do not drop the lens onto any hard surface or touch the lens with any sharp objects as this may damage the lens and reduce cutting efficiency. Always use cloths that are moistened with IPA optical cleaning solution; never use dry materials.

1. Remove the cutting head by releasing the M4 screw and detaching the pneumatic tube.

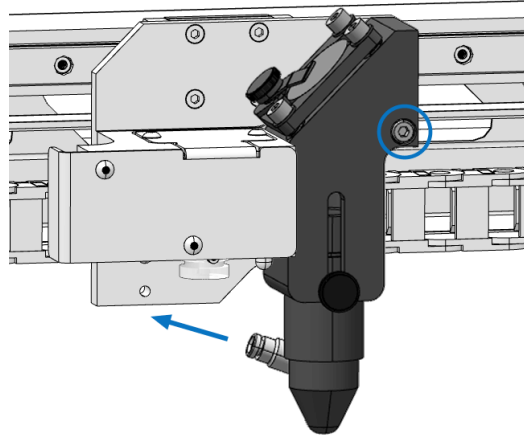

2. Place the cutting head onto a clean surface and unscrew the black thumb screw from the lens barrel. Slide out the barrel.

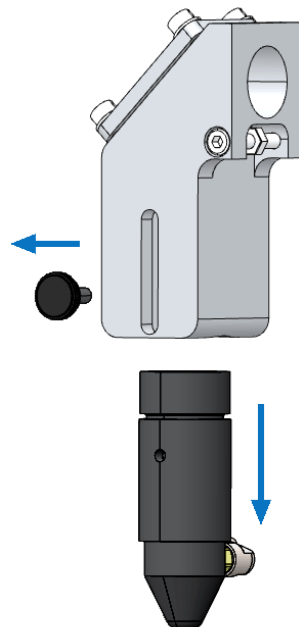

3. Remove the lens ring by turning it counterclockwise.



4. Carefully drop the lens onto a clean microfibre cloth.



WARNING: Ensure that the area is sufficiently ventilated. The solvent should be kept away from heat or flames. Wear appropriate clothing and safety goggles. Do not breathe in the fumes. Avoid contact with skin and eyes. If you get solvent on your skin or in your eyes, rinse thoroughly with clean, cold water and seek medical advice. Solvents are poisonous! If swallowed, get medical advice.



WARNING: Do not clean the optical components on the machine bed! Any IPA spillage onto the bed must be left for at least two hours to allow complete evaporation. Using the laser cutter with IPA on the bed will cause a fire!

5. Apply IPA to the lens surface, allow the IPA to work into the dirt and gently wipe in one direction, then again at 90 degrees. Repeat this for both sides of the lens.
6. Clean the surface or lip where the lens sits inside the barrel. Any dust on this surface will cause the lens to seat incorrectly and may affect laser alignment.

7. This is a good time to also clean the nozzle. For more information, refer to chapter 4.1.3.1 *Nozzle cleaning* on page 64.
8. Hold the edges of the lens with the surface curved outwards facing upward and carefully place it into the nozzle barrel. Install the same O ring or replace when there is visual damage.

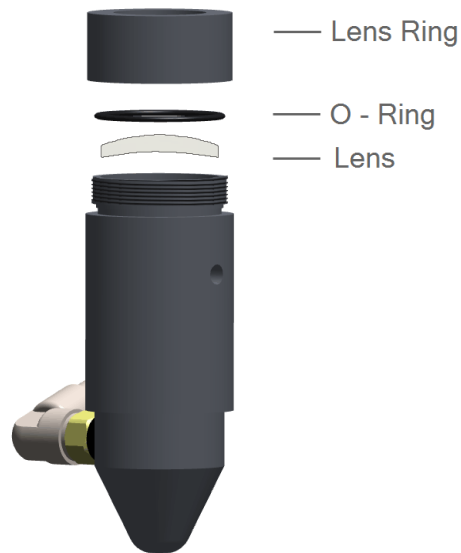

9. Re-fit the barrel into the cutting head and mount the cutting head back into the machine.



NOTE: The lens can be soaked in the solution for a few seconds to remove any stubborn residue.



NOTE: Do not touch the polished surfaces when handling the lens.

4.1.2.5 Cleaning the cutting head mirror

1. Remove the cutting head by releasing the M4 screw and detaching the pneumatic tube.

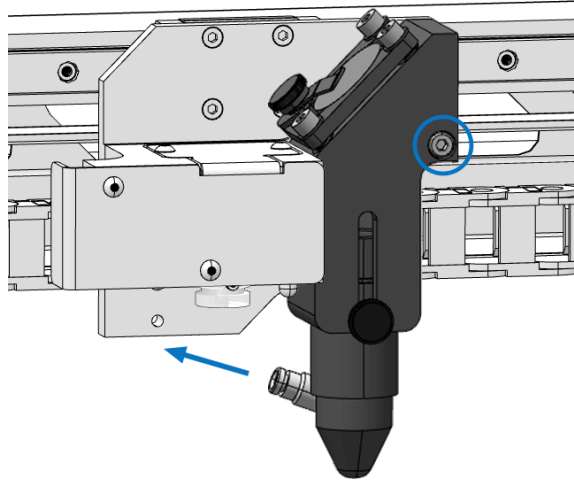

2. Release (do not remove) the mirror securing screw holding the mirror securing clip. Rotate the clip to release the mirror.

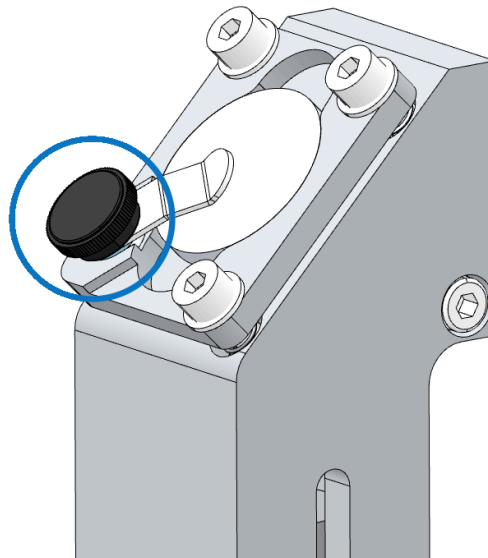

3. Gently rotate the head so that the mirror falls out onto a microfibre cleaning cloth. Apply IPA optical cleaning solution to the mirror face and let it soak for a few seconds. Gently lay an optical cleaning solution cloth on one edge of the mirror and gently draw the cloth right across the mirror in one continuous movement.



4. Inspect the mirror housing and clean the surface or the lip where the mirror sits. Any dust on this surface will cause the mirror to seat incorrectly and may affect laser alignment.

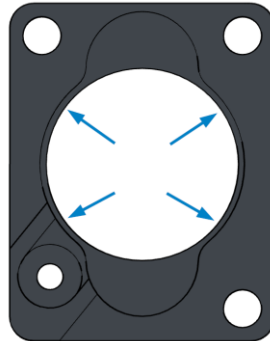

5. Place the mirror in the housing and secure it with the mirror securing clip and the mirror securing screw. Ensure that the securing clip has a slight bend in it to ensure that the mirror is secured correctly. Do not overtighten the mirror-securing screw!
6. Ensure the mating faces of the head and head bracket are clean. Any debris between these two faces may affect laser alignment. Attach the cutting head to the machine and secure with the M4 screw.

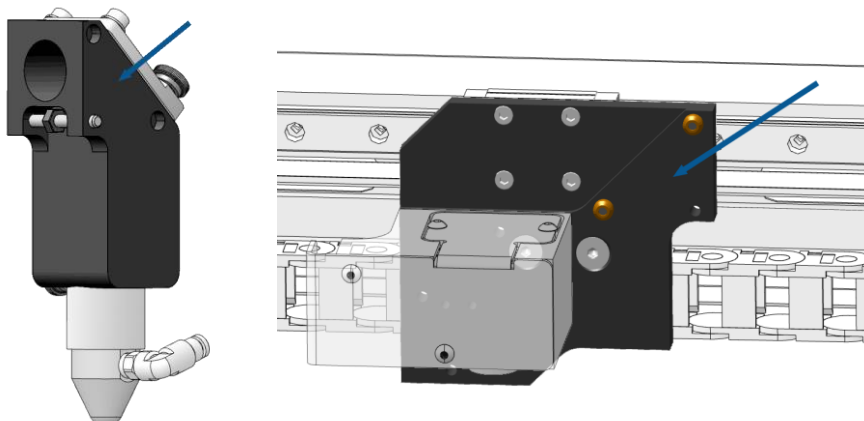

7. Reattach the pneumatic tube and set the nozzle height. For more information, refer to chapter 2.1.11.1 *Nozzle height* on page 18).

4.1.2.6 Cleaning the Vision camera lenses

The lenses of the Vision cameras in the gantry are accessible at any time; they are not covered. Use the air blower and/or soft brush to dust the lenses.



4.1.3 Pneumatics

4.1.3.1 Nozzle cleaning

To ensure proper airflow while cutting, the nozzle needs to be free of dirt. This step is preferably done with the barrel disassembled and the lens removed.

1. Remove the cutting head by releasing the M4 screw and detaching the pneumatic tube.

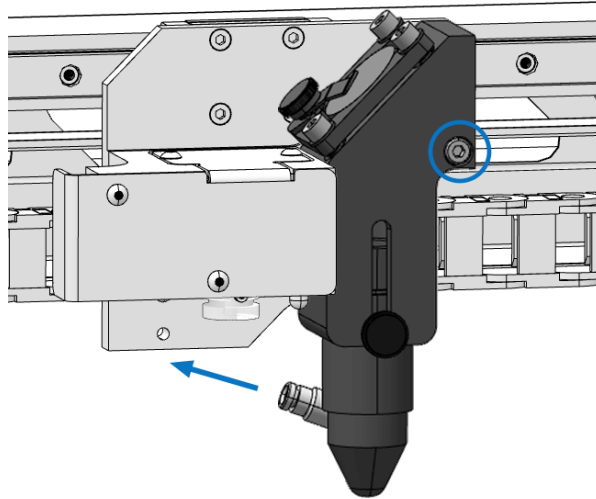

2. Clean the hole using a wooden toothpick. Use paper towel or a cloth to clean up the loose dirt and the outside of the nozzle. Use some IPA cleaning solution for stubborn residue.

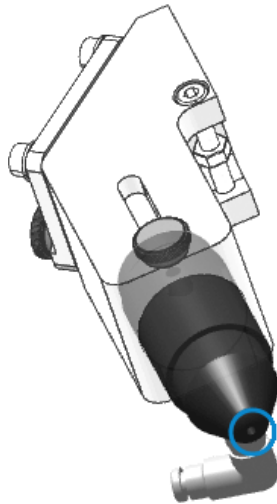

WARNING: Do not use an optical cleaning cloth as this may cause contamination.

3. Refit all components.

4.1.3.2 Airflow

Depending on the type of material being processed, an appropriate airflow must be present.

1. Find the pressure regulator at the back of the machine.
2. Check if all pneumatics tubes are still connected properly.
3. Check the pressure gauge to see if it is set properly: range between 0.5 bar (7.2psi) and 3 bar (43.51psi).

Inlet pressure (bar)	2 mm nozzle	
	l/min	l/h
0.5 (7.2psi)	45.4	2724
1	64.2	3852
1.5	80.3	4815
2	96.3	5778
2.5	112.4	6741
3 (43.51psi)	128.4	7704

4. Adjust the pressure by lifting the knob to unlock it. Then rotate until the desired pressure is achieved.

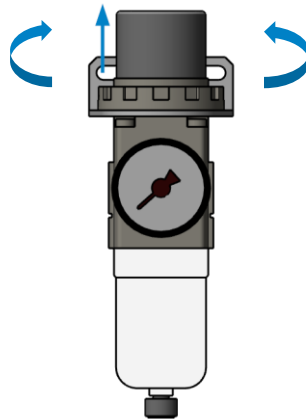

4.1.4 Axes

4.1.4.1 Axis movement

Check smooth movement on both axes. Use the arrow keys at the **Working area** action in GoProduce Laser edition to move the cutting head to each corner of the cutting bed and check for any irregularities.

4.1.4.2 Clean rails

The transport rails collect dust and lint which, reducing cutting performance.

1. Open the safety cover lid and the back panel using the control cabinet key.

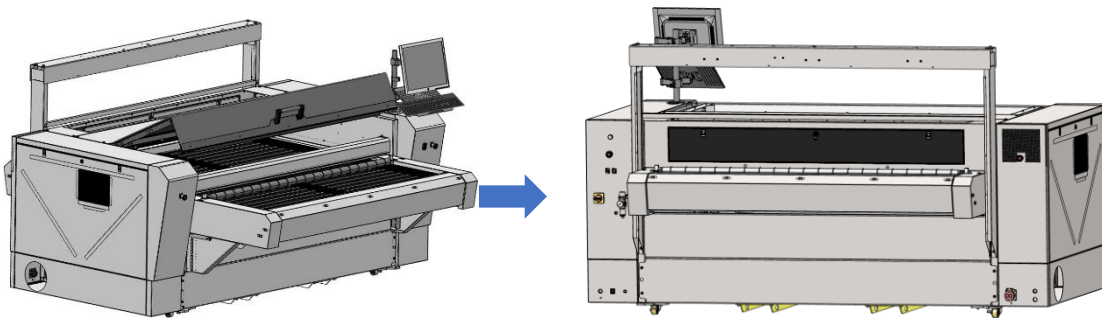

2. Open the front hinge cover.

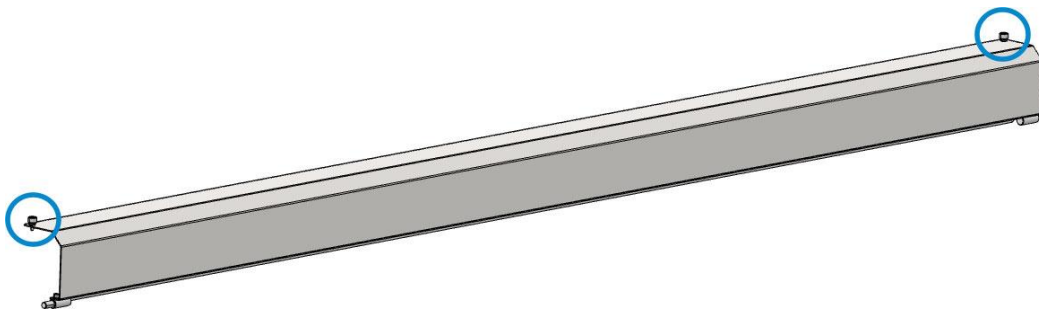

3. Visually inspect all rails to see if any dust or pieces of fabric are present.
4. If necessary, wipe the rail with a clean cloth until all dirt has been removed.
5. Lubricate the rails with multi grease (included in the toolbox).
6. Close the covers.

4.1.5 Air filters

To protect the internal components from surrounding dust particles, three filters are fitted around the machine.

1. Open the left and the right cover using the control cabinet key.

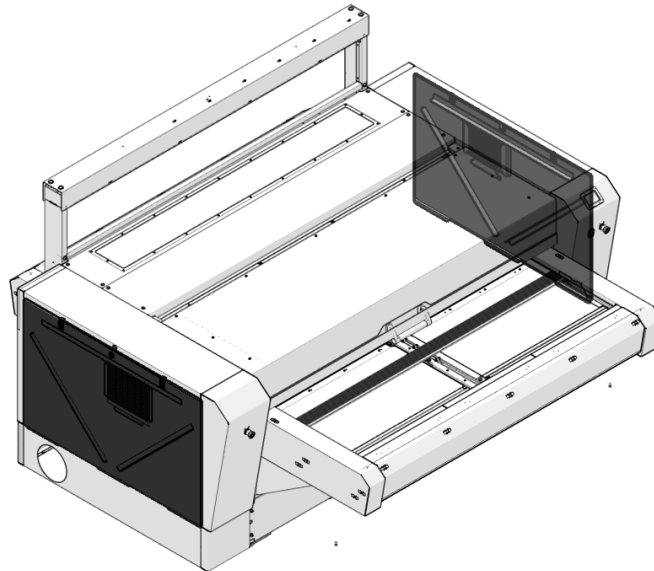

2. Remove the filter from the left/right cover and the back panel.

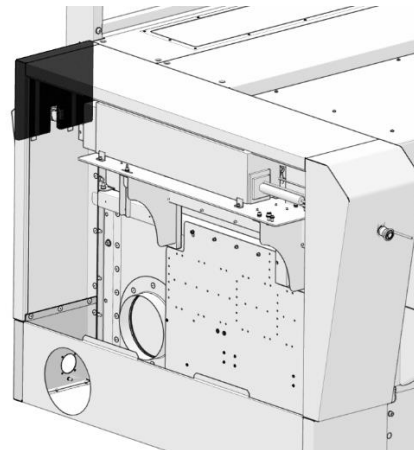
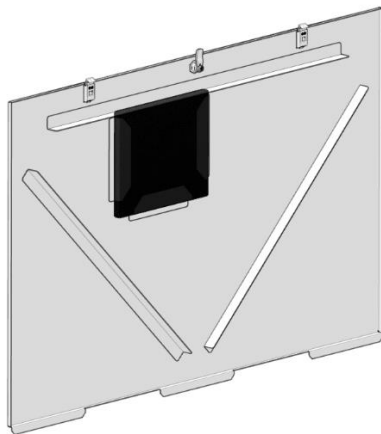

3. Vacuum all the filters.
4. Refit the filters and the covers.

4.1.6 Conveyor planks

To ensure proper fume extraction and vacuum for material transportation, the conveyor planks need to be free of dust and lint.

1. Open the safety cover lid and visually inspect the conveyor planks for cleanliness and damage.

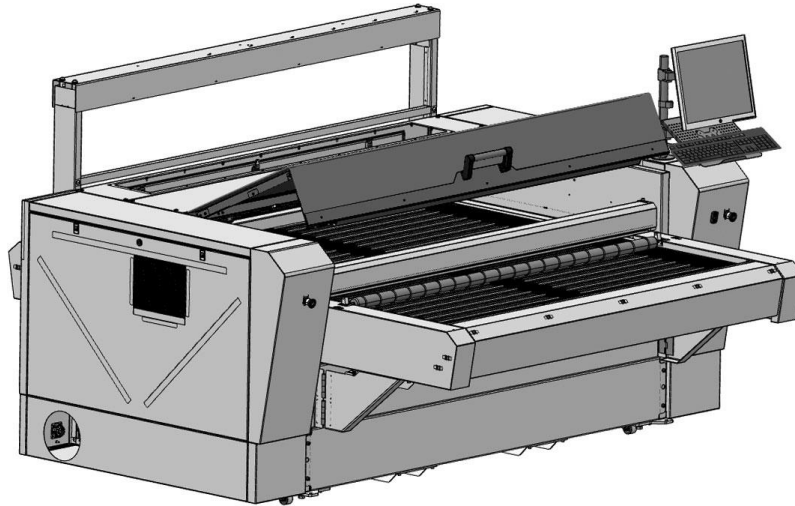

2. Remove large pieces of material by hand, then vacuum the planks.
3. Close the safety cover lid and feed the conveyor until an uncleaned set of planks is accessible.
4. Repeat all the above steps until all planks are clean.

4.2 Air-cooled laser

This section is only applicable if an air-cooled laser unit is installed inside the laser cutter. Check the serial number label on the back right of the machine. An air-cooled laser cutting machine type ends with /50 or /100.

4.2.1 Laser unit

Attention should be paid to proper airflow through the laser. Any restriction of airflow will result in reduced power output and may cause permanent power loss or failure over extended periods of time.

1. Open the left cover using the control cabinet key to gain access to the laser unit.

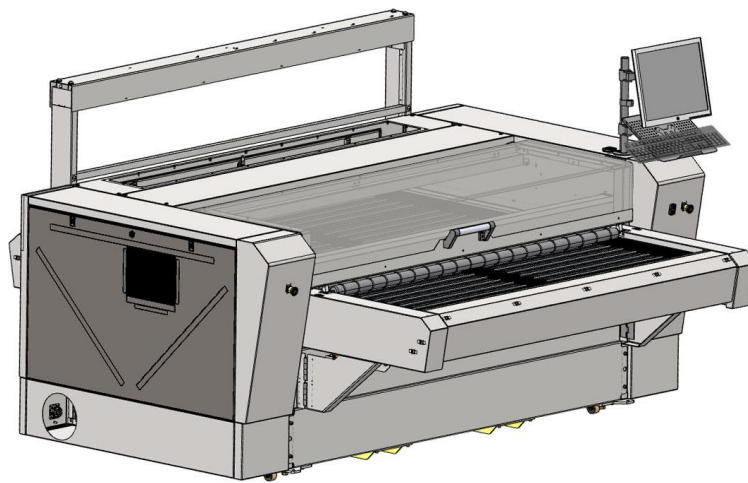

2. Vacuum the fans on the laser unit.

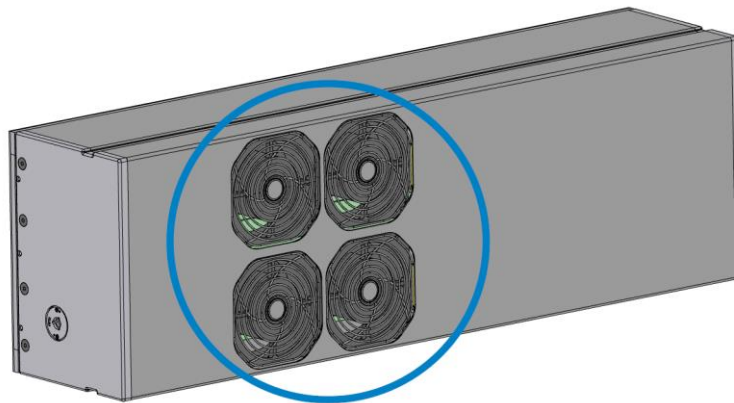

The number of fans depends on the laser model; the illustration is purely indicative.

4.3 Water-cooled laser

This section is only applicable if a water-cooled laser unit is installed inside the laser cutter. Check the serial number label on the back right of the machine. A water-cooled laser cutting machine type ends with /120 or /250.

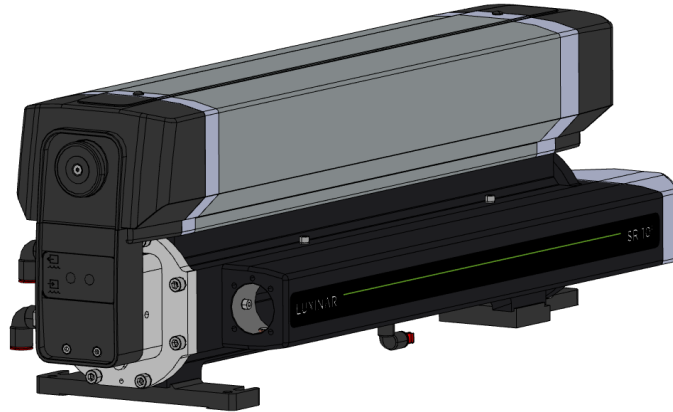

4.3.1 Water-cooled laser unit

The water-cooled laser unit has been designed to be low maintenance. Internal routine maintenance procedures are not required. The system's sealed construction and limited number of moving parts ensure trouble-free and reliable operation.

1. Open the left cover using the control cabinet key to gain access to the laser unit.

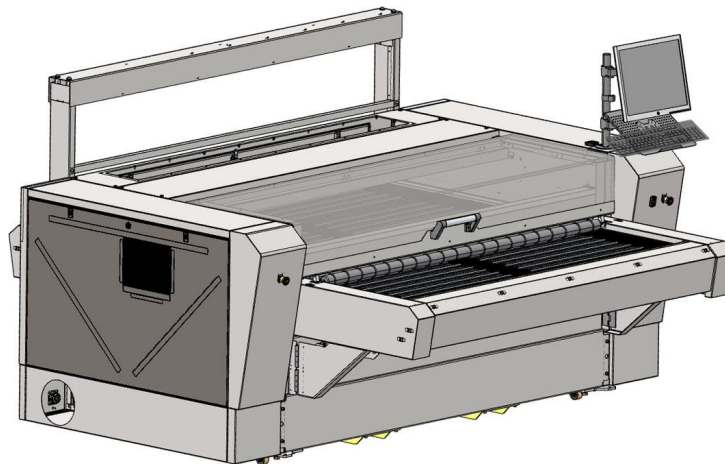

2. The external surfaces of the system can be cleaned with a mild detergent. It is advisable to use a damp cloth to facilitate the cleaning of the external cabinets.



WARNING: Take care not to allow entry of water into any of the electrical cabinets or onto the output window or primary beam delivery optic.

4.3.2 Chiller

The laser unit is cooled with deionised water, to avoid bacterial infestation.

4.3.2.1 Water level

The chiller needs a controlled water level to deliver full cooling capacity.

1. Check the water level through the inspection glass. The water level should be at least halfway.



Insufficient



Sufficient

2. If it is any lower than that, remove the reservoir cap and add deionised water until an appropriate level is reached.



3. Close the reservoir cap.

4.3.2.2 Water quality

Over time, the chiller water can become cloudy. Cloudy chiller water is no longer good for use. Replace with deionised water only.

1. Remove the reservoir cap.
2. Open the valve at the bottom of the chiller to drain all the chiller water.
3. Unplug the blue tube. Use compressed air (max 2 bar) to blow out the remaining water in the laser unit.
4. Plug the blue tube back in.
5. Flush the chiller with clean tap water once, then close the drain valve.
6. Refill the chiller with demineralized water. The reservoir holds approximately 22 litres.
7. Close the reservoir cap.

If desired, glycol can be added to the water to reduce bacteria growth. The ratio is 1 part glycol to 10 parts water.

4.3.2.3 Water pipes

To ensure proper water flow, the water hoses need to be in good condition and without kinks or sharp bends.

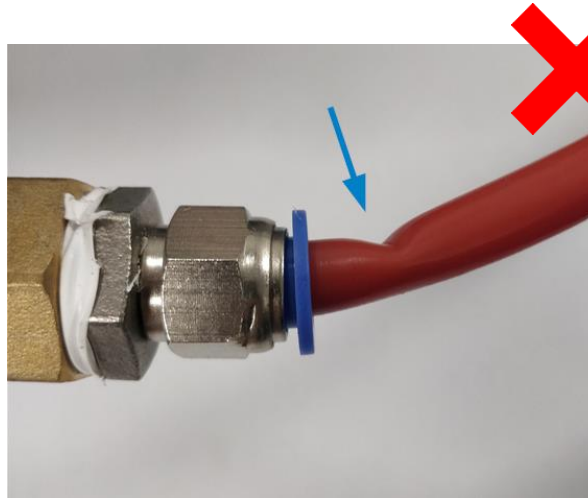

1. Close the *IN* and *OUT* valves on the chiller.



2. Drain the water from the damaged water hose.
3. Replace the water hose with a new one of the same length.

4. Refit the water hose into the chiller and open both valves completely.



4.3.2.4 Chiller air filter

To ensure proper airflow through the chiller, the grid and the air filter need to be free of dust. The filter can be easily removed by hand.

1. Lift the filter and tilt outwards to slide it out.



2. Use a vacuum cleaner and/or pressured air to clean the air filter.
3. Refit the air filter.

4.4 Extraction systems

To ensure proper fume extraction and vacuum in the cutting area, the extraction hoses need free of dust and debris.

1. Remove the vacuum hose from the extraction system (extraction fan, BOFA, or own system).

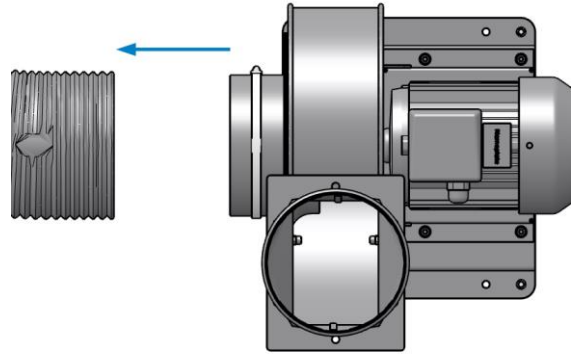

Illustration purely indicative

2. Visually inspect the inside of the fan and extraction hose. Remove any debris and/or large pieces of fabric.
3. Refit the extraction pipe.



NOTE: If the vacuum fails and the pump is spinning, it means that there is a blockage in the system. If there is a strong vacuum (but no airflow) between the pump and the machine, the extraction pipe between the pump and the outside world/factory vent network is blocked. If there is a loss of vacuum in the chamber, there's a blockage between the machine and the pump.

4.5 Maintenance Overview



ATTENTION: Make sure the power supply to the laser cutter is switched off before starting maintenance tasks!

ATTENTION: The intervals below are the maximum allowed time between maintenance tasks:



- 8 hours or one day*
- 40 hours or one week*
- 170 hours or one month*
- 1,000 hours or six months*
- 2,000 hours or one year*
- 4,000 hours or two years*

*Whichever is reached first.

If a component requires the performance of a maintenance task sooner than indicated below, do not delay.

LASER CUTTER				
Component	Task	By	Max. Interval*	Reference
Secondary Mirror	Clean	End User	1 Day	Page 56
Head Mirror	Clean	End User	1 Day	Page 61
Head Lens	Clean	End User	1 Day	Page 58
Nozzle	Clean	End User	1 Day	Page 64
Airflow Nozzle	Check	End User	1 Day	Page 65
Nozzle Height	Check	End User	1 Day	Page 18
Vision Camera Lenses	Clean	End User	1 Week	Page 63
Conveyor Planks	Check/Clean	End User	1 Week	Page 68
Air Filters	Clean/Replace	End User	1 Month	Page 67
Primary Mirror	Clean	End User	1 Month	Page 54
Emergency Stops	Check	End User	1 Month	
Axis Movement	Check/Clean	End User	1 Month	Page 66
Laser Beam Alignment	Check calibration	End User	1 Year	Page 30

LASER CUTTER				
Component	Task	By	Max. Interval*	Reference
Vision camera lens and scanning camera UV filter	Clean/Check calibration	Dealer	1 Year	
All Rails	Clean and Lubricate	Dealer	1 Year	
Belt Tension	Check/Adjust	Dealer	1 Year	
Motor Belt Tension	Check/Adjust	Dealer	1 Year	
Overall Machine Service (all the above)	Check	Dealer	1 Year	
All Optical Components	Replace	Dealer	2 Years	
Reprocess Laser Unit	Reprocess	Dealer	15 – 20K hours	

WATER-COOLED LASER				
Component	Task	By	Max. Interval	Reference
Chiller Water Level	Check	End User	1 Week	Page 71
Chiller Water Quality	Check	End User	1 Week	Page 72
Chiller Water Pipes	Check	End User	4 Weeks	Page 73
Chiller Air Filter	Clean	End User	4 Weeks	Page 74
Chiller Water	Replace	Dealer	6 Months	Page 72
Chiller Service	Service	Local ICS Dealer	1 Year	

AIR-COOLED LASER				
Component	Task	By	Max. Interval*	Reference
Laser Unit Fans	Clean	End User	4 Weeks	Page 69

EXTRACTION SYSTEMS				
Component	Task	By	Max. Interval*	Reference
Extraction Hoses	Clean	End User	2 Weeks	Page 75
Extraction Fan	Clean	End User	4 Weeks	
Vacuum Chamber	Clean	Dealer	1 Year	

5 INCLUDED ACCESSORIES

The following accessories are included with the purchase of your L1810 Gen2.6 laser cutter:

- Conveyor system (excl. planks)
- Front extension
- Head camera
- Pressure rollers
- Summa GoProduce Laser Edition (excl. computer)
- 50W air cooled laser tube¹
- 100W air cooled laser tube²
- 120W water cooled laser tube³
- 250W water cooled laser tube⁴
- Toolbox containing:
 - Split cable gland 0-20mm
 - Split cable grommet 4-5mm
 - Fuse 5A
 - Fuse 3A
 - Fuse 2A
 - IPA optical cleaning fluid + safety document
 - Laser safety glasses
 - Lens cleaning & polishing cloth
 - 3M Scotch-Brite 86 handpd
 - Hex key set long ballpoint
 - M4 black knurled claping knob
 - Shorter wrench spanner
 - Air dust blower
 - Open-ended spanner
 - Alignment targets
 - Ty-Rap natural 112x2.4mm
 - M4 10x cap head
 - M3 4x grub screw black
 - Key for latches
 - Lithium grase 100ml tube
 - O-ring 18.1x21.3
 - Loctite 406 20CC
 - Washer DIN125 M4
 - Spring washer D128A M4
 - ZnSe lens
 - Reflector
 - Target holder
 - Nozzle gauge
 - Nozzle target holder
 - Angled coupling 4mm
 - Summa GoProduce card

For information on the additional items that can be purchased for your cutting machine, please ask for the document *L1810Gen2.6_OptionsConsumablesAccessories*.

¹ In case of 50W laser cutter.

² In case of 100W laser cutter.

³ In case of 120W laser cutter.

⁴ In case of 250W laser cutter.

6 TROUBLESHOOTING

The laser is not cutting well in all areas of the bed:

- The focus height is incorrect.
- The lens is upside down.
- The optical components are in a poor state of cleanliness.
- The cutting nozzle is blocked with dirt.
- The wrong material has been chosen from the material manager
- The beam alignment has moved for some reason.
- Laser power has dropped.
- The 48V laser power supply has failed.

The laser is not cutting in the corners:

The minimum power in the material setting is too low.

The laser is burning the corners of thin material:

The minimum power in the material setting is too high.

The motion system is working but the laser is not firing:

- Check the status lights on the back of the laser.
- Check the chiller:
 - Water level (too low?)
 - Water pressure (too low?)
 - Water pipes (bent?)
 - Flow and return pipes have been exchanged.
 - Service or re-gas needed

The laser won't switch on:

- No mains power into the machine
- The mains isolator switch at the back of the machine is off
- One of the 4 emergency stops is pressed
- The 1-amp fuse on the main electric panel for the 24V start circuit has blown
- The 24V MCB has tripped to the OFF position

There are no errors, still the cutting head won't move to the 0/0 origin position:

- There is an obstruction somewhere in the motion system
- The linear rails haven't been maintained correctly and are dirty or sticky
- One of the motion system motors is tight or seized up

The conveyor is making a banging noise and is jamming:

- Check if the obstruction is in a repeatable position. If so, a fixing screw holding the bed planks in place may have come loose. Remove the 2 side covers and retighten.
- Material got caught somewhere in the conveyor.
- Remove the rear cover and remove any debris.

6.1 Error Messages

Error messages will be shown in the **Monitor** section of the **Device** tab in the program GoProduce Laser edition (so make sure it is always running).

An example of a warning is shown in the figure below.

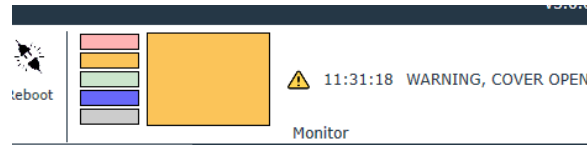

Warning message

An error can be fatal or non-fatal (warnings) but will require operator intervention either way. Fatal errors are marked with a large red rectangle, whereas warnings are marked with a yellow rectangle.

The table below gives an overview of the most common messages, possible causes and possible solutions.

Error Message	Possible Cause	Checks	Corrective Action
Close Cover	Open Covers	Check all Covers	Close all Covers
	Interlock switch damaged, not engaging or connection issue	Check all interlock switches and plugs	Replace or repair as necessary, or contact your agent
De-reeler Material End	End-of-roll sensor of unwinder uncovered	Check if material loop covers the sensor	Unwind material until sensor is covered
	Interlock switch damaged, not engaging or connection issue	Check all interlock switches and plugs	Replace or repair as necessary, or contact your agent

Error Message	Possible Cause	Checks	Corrective Action
AXIS ERROR (X, Y, or Feed)	Material or Object obstructing movement	Check affected area for any loose material, objects or thread that may have become entangled in moving parts	Remove any debris from moving parts
	Rail Dirty	Check the rail for any ingrained dirt built up over time	Remove dirt with green abrasive pad supplied with cutter, clean with soft cloth and apply small amount of Light Machine Oil (sewing machine oil)
	Carriage or Ball Slide damaged or loose	Power off the machine and SLOWLY move the head by hand feeling for any stiff or loose spots in the carriage(s)	If you suspect the Ball Slide or Carriage to be damaged, contact your agent
	Loop Drive Belt loose or damaged (orange or grey)	Check the Loop Drive Belt(s), ensure it is not loose and is located on the gears correctly	Refit or tighten the Loop Belt, if required clean between the teeth of the gears with a brush and apply Light Machine Oil
	Axis Belt loose or damaged (White)	Check the main Axis belt for damage, check if the belt is loose and ensure it locates on the pulleys correctly	Reposition or re-tension belt if necessary, or contact your agent
	Motor Connection issue	Check solder joints and connections to Main Control Board	Re-solder or reconnect as necessary, or contact your agent
	Motor Encoder issue	Check to see if the head is intermittently moving up/down or left/right out of its intended position	Replace Motor, or contact your agent
	Main Control Board issue	Axis still failed with replacement cable and motor	Replace control board, contact your agent

7 GOCARE

The GoCare software allows upgrading the laser cutter firmware, making device and Vision camera backups, and restoring machine settings.

The user manual of GoCare is available for download on our website (www.summa.com/en/support/user-manuals/).

8 GOPRODUCE LASER EDITION

Summa GoProduce Laser Edition is a Windows-based production software that integrates the L-Series into the workflow. It is the perfect link between the design station, RIP station, printers and cutting devices. Once the workflow is set up, macros automate the process. Consequently, the number of times the operator has to intervene to start the next job is reduced to a minimum, as is the downtime of the machine.

The user manual of GoProduce Laser Edition is available for download on our website (www.summa.com/en/support/user-manuals/).