

USERS MANUAL



Information



Table of Contence

USER'S MANUAL FOR THE

Summa

The logo for Summa Crest features the word "Summa" in a bold, black, sans-serif font. Below it, the word "Crest" is written in a stylized, black, cursive script font. The "C" in "Crest" is particularly large and loops around the "S" in "Summa".

Series

IMPORTANT

Before you begin...

Please complete the attached Warranty Registration Card and return it to Summa today. (Users outside Europe, Africa and the Middle East should check the address on the back of the Warranty Registration Card.)

Failure to return the duly completed Warranty Registration Card might delay response to your warranty and service enquiries.

NOTE

When selecting software drivers: If the Summa name is not mentioned in the list of available software drivers, use Summagraphics drivers.



FCC NOTICE

The SummaCut series cutters have been tested and found to comply with the limits for a Class A digital device, pursuant to Part 15 of the FCC Rules. These limits are designed to provide reasonable protection against harmful interference when the equipment is operated in a commercial environment. These cutters generate, use, and can radiate radio frequency energy and, if not installed and used in accordance with the instruction manual, may cause harmful interference to radio communications. Operation of these cutters in a residential area is likely to cause harmful interference in which case the user will be required to correct the interference at his own expense.

Caution !

Changes or modifications, not expressly approved by Summa, who is responsible for FCC compliance, could void the users authority to operate this equipment.

DOC NOTICE

The SummaCut-series cutters do not exceed the Class A limits for radio noise for digital apparatus set out in the Radio Interference Regulations of the Canadian Department of Communications.

NOTICE

Summa reserves the right to modify the information contained in this User Manual at any time without prior notice. Unauthorized copying, modification, distribution or display is prohibited. All rights reserved. All queries, comments or suggestions concerning this and other Summa manuals should be directed to :

Americas and Asia Pacific

Summa, Inc.
372 North Billy Mitchell Road
Salt Lake City, Utah 84116
USA

Tel +(01) 801-355-6669
Fax +(01) 801-355-4446

Europe

Summa NV
Rochesterlaan 6
8470 GISTEL
Belgium

Tel +32 59 270011
Fax +32 59 270063

© Copyright 1999, Summa.

TRADEMARK ACKNOWLEDGEMENTS

3M and Scotchcal are trademarks of the 3M Corp.

Arlon is a trademark of Keene Corp.

DM/PL and Houston Instrument are trademarks of Summagraphics Corporation.

Fasson is a trademark of Avery.

Gerber is a trademark of Gerber Scientific Products, Inc.

Grafitack is a trademark of Grafityp.

HP-GL is a trademark of Hewlett-Packard Company.

IBM PC, IBM PC/XT, and IBM AT are trademarks of International Business Machines Corp.

Kapco is a trademark of Kent Adhesive Products Co.

Macintosh, Macintosh Plus, Macintosh SE, and Macintosh II are trademarks of Apple Computer.

MACTac is a trademark of MACTac Europe.

Multifix is a trademark of Multiplast Grafics.

Rubylith is a trademark of Ulano.

Tesa and Tesacal are trademarks of Tesa.

TABLE OF CONTENTS		Page
1.	GENERAL INFORMATION	
1.1.	Introduction	1-1
1.1.1.	Product features.....	1-1
1.1.2.	SummaCut Series User Manual	1-3
1.2.	Specifications	1-4
1.2.1.	Cutter.....	1-4
1.2.2.	Media	1-4
1.2.3.	Knife, pen and pouncing tool	1-5
1.2.4.	Interface.....	1-6
1.2.5.	Firmware.....	1-6
1.2.6.	Performance.....	1-7
1.2.7.	Certifications	1-7
1.2.8.	Environmental.....	1-7
1.2.9.	Electrical	1-8
1.3.	Cutter accessories and consumables	1-9
1.4.	Rear panel components	1-10
1.5.	Front panel controls	1-11
1.6.	Powering up the cutter	1-13
1.6.1.	Grounding.....	1-13
1.6.2.	Power-up procedure	1-14
1.7.	Installation of a knife, pen or pouncing tool	1-15
1.7.1.	Knife installation.....	1-15
1.7.2.	Pen installation.....	1-18
1.7.3.	Installation of a pouncing tool	1-19
1.8.	Loading media	1-20
1.8.1	Positioning the pinch rollers	1-20
1.8.2.	Feeding and positioning media.....	1-21

2. OPERATION

2.1.	The control panel	2-1
2.1.1	The Origin key	2-1
2.1.2	The Online key	2-2
2.1.3	The Jogging keys	2-3
2.1.4	The LED Indicators	2-3
2.1.5	The boot keys	2-4
2.2.	Summa Cutter Control	2-5
2.2.1	Knife pressure	2-5
2.2.2	Pouncing pressure	2-5
2.2.3	Knife offset.....	2-5
2.2.4	Pouncing gap	2-6
2.2.5	Velocity	2-6
2.2.6	Overcut	2-6
2.2.7	Concatenation	2-6
2.2.8	Smoothing	2-7
2.2.9	Language	2-7
2.2.10	Tool	2-7
2.2.11	Addressing	2-8
2.2.12	Baud rate	2-8
2.2.13	Parity	2-8
2.2.14	RTS/DTR	2-9
2.2.15	HP-GL origin	2-9
2.2.16	Media sensors	2-9
2.2.17	Autoload	2-9
2.2.18	Tool command.....	2-10
2.2.19	LOAD ON W command.....	2-10
2.2.20	Flex-Cut	2-10
2.2.21	Cut Length	2-10
2.2.22	Flex-Cut Length.....	2-11
2.2.23	Flex Pressure	2-11
2.2.24	Recut offset.....	2-11
2.2.25	Recut	2-11

3.	MAINTENANCE AND CLEANING	
3.1.	Maintenance	3-1
3.1.1	Cleaning the drive system.....	3-1
3.1.2	Cleaning the sensors.....	3-2
3.2.	Operating voltage conversion	3-3
4.	INTERFACE	
4.1.	Introduction	4-1
4.2.	Interface notes	4-1
4.2.1	System setup	4-1
4.2.1.1	MS-DOS or PC-DOS operating system	4-1
4.2.1.2	Windows 3.xx.....	4.2
4.2.1.3	Windows 95	4.2
4.2.2	Serial interface connector on cutter	4-3
4.3.	Available serial signals	4-3
5.	CONTOUR CUTTING	
5.1.	Introduction	1
5.2.	General	5
5.3.	Creating the design	5
5.4.	Placing the Cross-marks	6
5.5.	Print the design	7
5.6.	Loading the cutter and setting the parameters	8
5.7.	Registrating the cross-marks	9
5.8.	Cutting the contour	10

APPENDIX A:

MEDIA CERTIFICATION A-1

ADDRESSES A-3

LIST OF ILLUSTRATIONSPage

1-1 SummaCut Series cutter, rear view 1-10

1-2 SummaCut Series cutter, front view..... 1-11

1-3 Ground connection 1-14

1-4 Blade insertion 1-15

1-5 Blade length adjustment 1-16

1-6 Setting knife depth 1-16

1-7 Knife depth test pattern 1-17

1-8 Pinch roller lever 1-21

1-9 Feeding roll media 1-22

1-10 Pinch roller positioning 1-23

2-1 SummaCut Series cutter, control panel 2-1

3-1 Cleaning of the friction drive system 3-2

3-2 Location of the sensors 3-2

3-3 Power entry module 3-3

LIST OF TABLESPage

1-1 SummaCut Series cutter specifications 1-4

1-2 SummaCut Series media specifications 1-4

1-2 SummaCut Series media specifications (continued)..... 1-5

1-3 SummaCut Series knives, pens and pouncing tools 1-5

1-4 SummaCut Series interface specifications..... 1-6

1-5 SummaCut Series firmware 1-6

1-6 SummaCut Series performances 1-7

1-7 SummaCut Series environmental specifications 1-7

1-8 SummaCut Series electrical specifications 1-8

1-9 SummaCut Series accessories and consumables 1-9

2-1 LED Indication 2-3

SECTION 1

GENERAL INFORMATION

1.1. INTRODUCTION

The SummaCut range of cutters has been designed to produce computer-generated graphic designs on cut sheet or roll vinyl media. By replacing the knife with a fibre tip pen, the cutter can also be used to produce inexpensive previews of new graphic designs on paper.

This manual covers the following SummaCut Series cutter models:

- The SummaCut D520, which can handle media widths from 70 mm up to 675 mm (2.7" to 26.6")
- The SummaCut D620, which can handle media widths from 70 mm up to 775 mm (2.7" to 30.5")
- The SummaCut D760, which can handle media widths from 70 mm up to 915 mm (2.7" to 36")
- The SummaCut D1020, which can handle media widths from 120 mm up to 1175 mm (4.7" to 46.3")
- The SummaCut D1220, which can handle media widths from 120 mm up to 1375 mm (4.7" to 54.1")

The term 'summaCut Series Cutters' is used when information is provided which is common to all members of this series. The specific model terms D520, D620, D760, D1020 and D1220 are used when information pertains only to that particular model.

1.1.1. PRODUCT FEATURES

The following are the main features of the SummaCut Series cutters.

- Easy to use computer control via software utility.
- Variable media widths.

- Interchangeable pen for producing preview plots of sign designs on paper.
- Interchangeable pouncing tool.
- Adjustable knife pressure and offset settings controlled by microprocessor.
- Communication with host computer via standard serial RS-232-C interface.
- 6-key control panel with LED indicators.
- Metric or English units.
- Menu mode for selection of the cutter' s power-up operating configuration, controlled by microprocessor.
- Wide variety of axial cutting speeds (in metric or English units).
- Up to four separate user configurations stored in the non-volatile memory.
- Automatic media pull from roll.
- Automatic media sensing.
- User changeable origin to any location.
- Concatenation and curve smoothing to obtain better cut quality.
- Manual knife for cutting off the finished sign.
- Knife depth and offset test.
- Overcut for easy weeding.
- Optional media support system to guarantee tracking of longer signs (Standard for D1020 and D1220).
- User-selectable DM/PL™, HP-GL™ and HP-GL/2™ software protocols.
- Optional stand (Standard for D1020 and D1220).
- Multiple recut feature

1.1.2. SUMMACUT SERIES USER' S MANUAL

The User' s Manual provides the following information :

- Full technical specifications for the SummaCut Series cutters and the media to be cut.
- A complete description of the SummaCut Series main components.
- Step-by-step instructions for knife and pen installation, and media loading.
- Instructions for online and local mode (🖱️) operations.
- Information on the control panel and the cutter' s parameters.
- Maintenance and cleaning instructions.
- Information about the RS-232-C interface cables used to inter-connect the cutter and IBM, IBM-compatible, Macintosh and Macintosh-compatible host computers.

1.2. SPECIFICATIONS

1.2.1. CUTTER

	D520		D620		D760		D1020		D1220	
	mm	inch	mm	inch	mm	inch	mm	inch	mm	inch
Height	395	15.6	395	15.6	395	15.6	1010	39.8	1010	39.8
Width	890	35	990	40	1120	52	1390	54.7	1590	62.6
Depth	200	7.9	200	7.9	200	7.9	390	15.4	390	15.4
Weigh	17 kg	37 lbs	18 kg	40 lbs	20 kg	44 lbs	40 kg	88 lbs	45 kg	99 lbs

TABLE 1-1 :
SUMMACUT SERIES CUTTER SPECIFICATIONS

1.2.2. MEDIA

		D520		D620		D760		D1020		D1220	
		mm	inch	mm	inch	mm	inch	mm	inch	mm	inch
Width	Roll	220 to 610	8.6 to 24	220 to 710	8.6 to 28	220 to 850	8.6 to 33.5	220 to 1110	8.6 to 43.7	220 to 1310	8.6 to 51.6
	Sheet	70 to 675	2.7 to 26.6	70 to 775	2.7 to 30.5	70 to 915	2.7 to 36	120 to 1175	4.7 to 46.2	120 to 1375	4.7 to 54.1
Tracking performance		4m/13 feet max. within guaranteed specifications*						-8 m/26 feet max. within guaranteed specifications* for media less than 750 mm (30" wide). -4m/13 feet max. within guaranteed specifications** for media larger than 750 mm (30").			
Thickness		0.05 to 0.8	0.002 to 0.030	0.05 to 0.8	0.002 to 0.030	0.05 to 0.8	0.002 to 0.030	0.05 to 0.8	0.002 to 0.030	0.05 to 0.8	0.002 to 0.030
Max.Cutting/Plotting area		500 mm x 50 m.	19.7" x 164 ft.	600 mm x 50 m.	23.6" x 164 ft.	740 mm x 50 m.	29.1" x 164 ft.	1000 mm x 50 m	39.4" x 164 ft.	1200 mm x 50 m	47.2" x 164 ft.
Minimum Margins**		25	1	25	1	25	1	25	1	25	1

TABLE 1-2 :
SUMMACUT SERIES MEDIA SPECIFICATIONS

		D520		D620		D760		D1020		D1220	
Front margin		18	0.7	18	0.7	18	0.7	18	0.7	18	0.7
Rear margin	Sensor on	42	1.7	42	1.7	42	1.7	42	1.7	42	1.7
	Sensor off	25	1	25	1	25	1	25	1	25	1

* Media lengths greater than 4 m (13 feet) can be handled, but compliance with specifications is not guaranteed (will be dependent on media type, media size and other parameters not mentioned here). With the optional media support system, the tracking performance is 8 m / 26 feet.

** For positioning of the pinch rollers (see section 1.8.)

TABLE 1-2 :
SUMMACUT SERIES MEDIA SPECIFICATIONS (CONTINUED)

Vinyl Types

A wide range of vinyl types has been evaluated and tested on the SummaCut Series cutters. When using duly certified media, operation in accordance with the functional specifications of the model is warranted. Other media should be certified by Summa before use to ensure performance in compliance with specifications.

For a full list of all duly certified media suitable for friction drive operation, see Appendix A.

Plotting Paper

Bond paper (120 g/m² recommended)

1.2.3. KNIFE, PEN AND POUNCING TOOL

The SummaCut cutters are supplied with two standard knife blades (for vinyl media) and a black fibre tip pen.

Knife	<i>Medium</i>	<i>Quantity</i>
Standard knife	standard, reflective & fluorescent vinyl types	2 off
Knife for masking stencil	masking stencil & thick material	optional

Pen	<i>Colour</i>	<i>Quantity</i>
Fibre tip pen	black	1 off
Pouncing tool	<i>Paper</i>	<i>Optional</i>

TABLE 1-3:
SUMMACUT SERIES KNIVES, PENS AND POUNCING TOOLS

To order replacement knives, pens and/or pouncing tools, contact your local dealer, quoting the part numbers listed in [table 1-9](#).

The SummaCut cutters will only perform according to specifications if a genuine Summagraphics knife, pen or pouncing tool is installed. Do not replace the standard knife, pen or pouncing tool with products from other manufacturers.

1.2.4. INTERFACE

Communication	asynchronous RS-232-C
Serial : I/O Port connector	DB-9P
Mating connector	DB-9S
Byte format	8 data bits, 2 stop bits, no parity
Baud rate	38400, 19200, 9600, 4800, 2400 BPS

TABLE 1-4:
SUMMACUT SERIES INTERFACE SPECIFICATIONS

1.2.5. FIRMWARE

Language	DM/PL, HP-GL (758x emulation), HP-GL/2
Supported character sets	Standard ASCII
Supported fonts	Sans serif (single stroke & medium)
ROM-based plots	Confidence plot, DIN plot

TABLE 1-5:
SUMMACUT SERIES FIRMWARE

1.2.6. PERFORMANCE

Cutting specifications on 0.05 mm (0.002") wax-backed vinyl, total media thickness not greater than 0.25 mm (0.010")

Axial speed	50 to 600 mm/s	2 to 24 ips
Default speed	500 mm/s	20 ips
Acceleration	up to 2 G	up to 2 G
Addressable resolution	0.025 mm, 0.1 mm	0.001", 0.005"
Default resolution	0.025 mm	0.001"
Mechanical resolution	0.0127 mm	0.0005"
Accuracy	0.2% of move or 0.25 mm, whichever is greater*	0.2% of move or 0.010", whichever is greater*
Knife pressure	0 to 400 gr.	0 to 400 gr.
Pen pressure	0 to 400 gr	0 to 400 gr.
Pouncing pressure	0 to 400 gr	0 to 400 gr.

*Excludes differences due to media expansion, stretching, etc.

TABLE 1- 6:
SUMMACUT SERIES PERFORMANCES

1.2.7. CERTIFICATIONS

CE-Certification
 FCC Class A
 EN50022:1987
 EN50082-2:1995
 IEC 950 , EN 60950
 UL 1950
 CSA 950

1.2.8. ENVIRONMENTAL

(cutter without media)

Operating Temperature	15 to 35° C	59 to 95° F
Storage temperature	-30 to 70° C	-22 to 158° F
Relative humidity	35 - 85 %, non condensing	35 - 85 %, non condensing

TABLE 1-7:
SUMMACUT SERIES ENVIRONMENTAL SPECIFICATIONS

**IMPORTANT HINT**

The use of dimensionally stable media is an essential pre-requisite to obtaining high cut quality. Additionally, media expansion or contraction may occur as a result of temperature variations. To improve the dimensional stability of media, let it stabilise to the current environmental conditions before usage for a minimum period of 24 hours.

1.2.9. ELECTRICAL

Main Supply : 48-62 Hz, single phase.

Nominal line	Min./Max. line	Fuse D520/D620/D760	Fuse D1020/D1220
100 V AC	89 - 108 V AC	1.0 A, Slo-Blo	1.25 A, Slo-Blo
120 V AC	108 - 130 V AC	1.0 A, Slo-Blo	1.25 A, Slo-Blo
220 V AC	197 - 238 V AC	0.5 A, Slo-Blo	0.6 A, Slo-Blo
240 V AC	216 - 260 V AC	0.5 A, Slo-Blo	0.6 A, Slo-Blo

TABLE 1-8:
SUMMACUT SERIES ELECTRICAL SPECIFICATIONS

1.3. CUTTER ACCESSORIES AND CONSUMABLES

The following accessories and consumables are available for your SummaCut Series cutter :

OPTIONS/ ACCESSORIES/ CONSUMMABLES	SUMMACUT D520/D620/ D760, D1020 and D1220
User's Manual	MD9020
Power Supply Cables	market specific
Serial Interface Kit, consisting of: - 9 pin to 9 pin cable - 9 pin to 25 pin conv. - 9 pin to 8 pin DIN conv.	423-155
Standard knife	391-360
Standard knife holder	391-332
Sandblast knife	391-358
Media support system D520 D620 D760	398-528 398-628 398-728
Stand D520 D620 D760	398-550 398-650 398-750
Sandblast knife holder	391-363
Fiber tip pen black	MP0635
Razor blade & holder	391-142
Pouncing tool	391-980

TABLE 1-9:
SUMMACUT SERIES ACCESSORIES AND CONSUMABLES

1.4. REAR PANEL COMPONENTS

In order to get acquainted with your SummaCut cutter, read the following description of the rear panel components. Figure 1-1 shows the location of the main components.

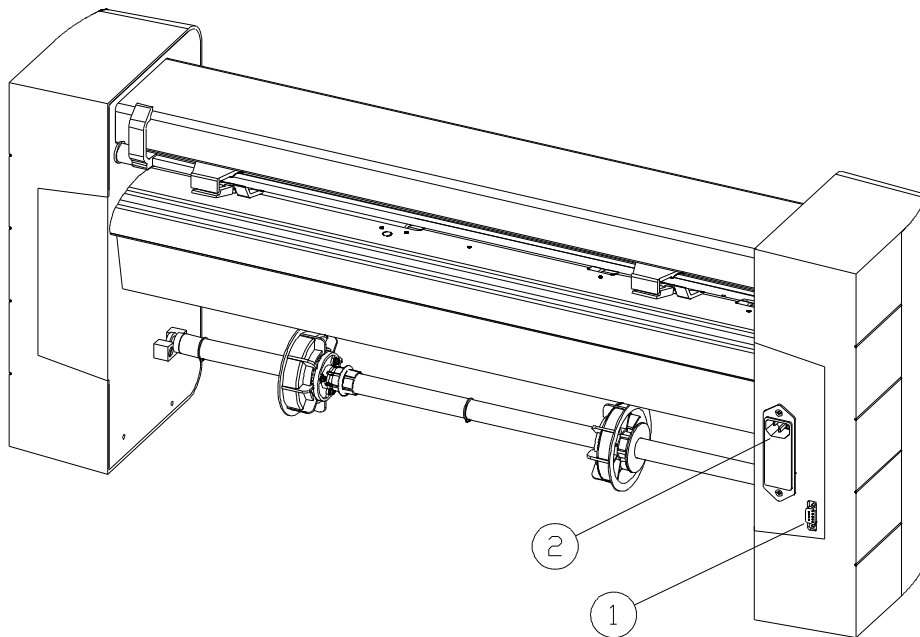

FIGURE 1-1:
SUMMACUT SERIES REAR VIEW

1. **RS-232-C Port.**- This DB-9P connector provides the communication link between the cutter and a host computer. It allows bidirectional communication between the host computer and the cutter.
2. **Power Entry Module.**- The fuse box, the voltage select board and the AC power cord receptacle are located in the power entry module. The power-up procedure is explained in detail in [Section 1.6](#). For information on the conversion of the cutter's operating voltage, see [Section 3.2](#).

1.5. FRONT PANEL CONTROLS

In order to get acquainted with your SummaCut cutter, read the following description of the front panel controls and components.

Figure 1-2 shows the location of the main components.

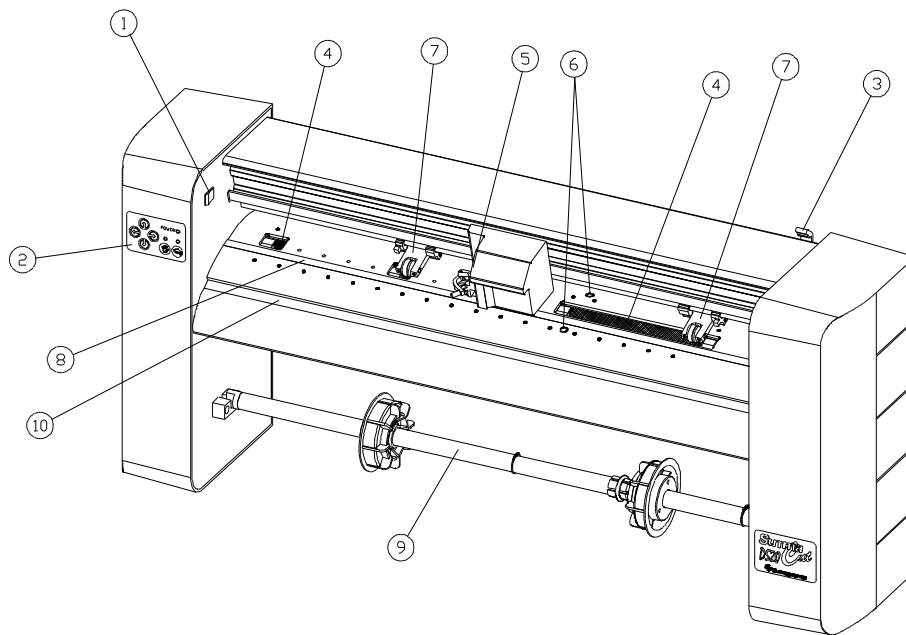



FIGURE 1-2:
SUMMACUT SERIES, FRONT VIEW

1. **Power ON/OFF switch.** - This rocker switch sets the cutter's power to ON or OFF. To switch the power ON, press the "I" side of the rocker switch. To switch the power OFF, press the "O" side of the rocker switch.
2. **Control Panel.** - The control panel contains 6 keys. Each control panel function is explained in [Section 2.1](#).
3. **Pinch roller lever arm.**- This lever is used to raise and lower the pinch rollers during media loading (Media loading is discussed in [Section 1.8](#)).
4. **Media Drive Sleeves.**- The media drive sleeves move the media only when the pinch rollers are in the 'down' position.
5. **Tool Carriage.** - The tool carriage is the mount for the knife holder and the pen .

6. **Sensors.** - The sensors detect the presence of a media to avoid any damage to the cutting strip. Upon powering up the machine, they cause the media to move all the way to the front edge of the platen.
7. **Pinch rollers.**- The pinch rollers hold the media clamped between the rubber rollers and the media drive sleeves.
8. **Cutting strip.**- Soft strip to avoid any damage to the knife tip when no media has been loaded. Since cutting is done on the cutting strip, it is essential that the cutting strip remains intact.
9. **Roll feed.** - This shaft can be removed from the cutter and inserted into a media roll.
10. **Manual cutting knife border:** - This border can be helpful when cutting off the sheet with the slitter knife.

1.6. POWERING UP THE CUTTER

1.6.1. GROUNDING



SAFETY WARNING

An insulated ground conductor must be installed as part of the branch circuit which supplies power to the wall outlet to which the cutter is connected. The ground conductor must have the same size, insulation material and thickness as the grounded and ungrounded branch-circuit supply conductors, but the insulating sheath should be green, or green with yellow striping.

The ground conductor described above must be grounded at the electrical distribution board, or, if power is supplied by a separate system, at the power supply transformer/motor generator set.

The wall sockets into which the cutter is plugged must be of the grounded type. The grounded conductors serving said wall sockets must be properly connected to ground.



CAUTION

Before plugging in the cutter' s power cord to a power source, make sure the cutter is set to the correct operating voltage (100 V, 120 V, 220 V, or 240 V AC) ([See section 3.2.](#))

See [Table 1-8](#) for the minimum and maximum operating voltage for the different voltage ratings.

To check the operating voltage setting, locate the power entry module (shown in [Figure 1-1](#)) on the cutter' s rear panel. The power entry module shows four possible voltage settings (100 V, 120 V, 220 V and 240 V). A pin next to one of the voltage settings indicates the voltage setting currently selected for the cutter. If this setting does not match the voltage supplied to your site, you will have to change the voltage setting prior to powering up the cutter.

For information about the conversion of the cutter's operating voltage and the exact fuse ratings, see [Section 3.2](#).

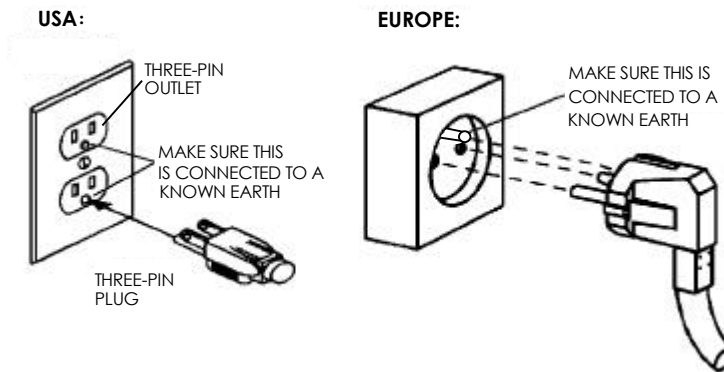



FIGURE 1-3:
GROUND CONNECTION



IMPORTANT OPERATIONAL TIP

This cutter must only be used with a power outlet that is properly grounded to ground. Use of an ungrounded outlet exposes the operator to risk of electric shock and will also lead to malfunctioning of the cutter.

1.6.2. POWER-UP PROCEDURE

➔ To power up the cutter, proceed as follows:

1. Make sure the cutter is placed on a flat, level and sturdy surface.
2. Plug one end of the AC power cord into the AC power cord receptacle on the cutter's rear panel.
3. Plug the other end of the AC power cord into the wall socket.
4. Press the "I" side of the ON/OFF rocker switch on the left side plate to switch the cutter ON.
5. The Power LED will flash up, and if media is loaded, the standard loading procedure will take place.

1.7. INSTALLATION OF A KNIFE, PEN OR POUNCING TOOL

1.7.1. KNIFE INSTALLATION



SAFETY WARNING

Your cutter uses razor-sharp knives. The knife blades may cause serious personal injuries if handled without proper care. Use extreme care when operating the cutter and when installing, removing or handling the knife!

→ To set up your cutter for knife operation, proceed as follows.

1. As shown in Figure 1-4, insert the knife blade into the knife holder using a pair of tweezers.

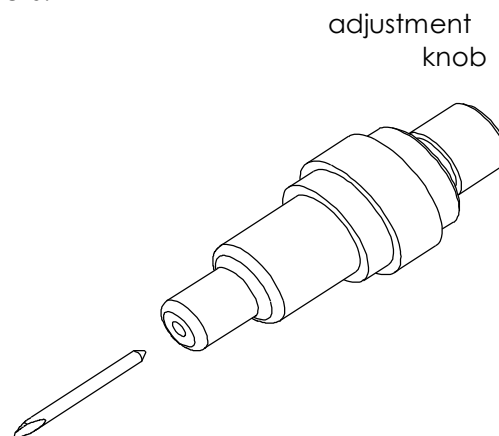

FIGURE 1-4
BLADE INSERTION

2. Set the knife blade length to zero by aligning the blade tip with the tip of the holder. An easy way of performing this is by holding the knife holder against your fingertip and gradually increasing the blade length by turning the adjustment knob until you feel the knife tip touching your fingertip.
3. Extend the tip of the blade by the distance required for the desired cutting media (**t**), as shown in [Figure 1-5](#). The blade should only extend beyond the knife holder sufficiently far to completely cut through the film layer, yet avoid penetrating through the backing, which would risk cutting into and damaging the cutting strip.

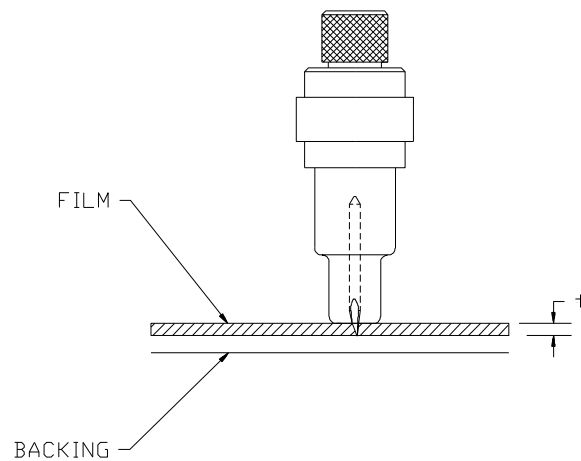

FIGURE 1-5
BLADE LENGTH ADJUSTMENT

4. Turn the cutting depth adjustment screw clockwise to increase the cutting depth. Turning the cutting depth adjustment screw anticlockwise will decrease the cutting depth.

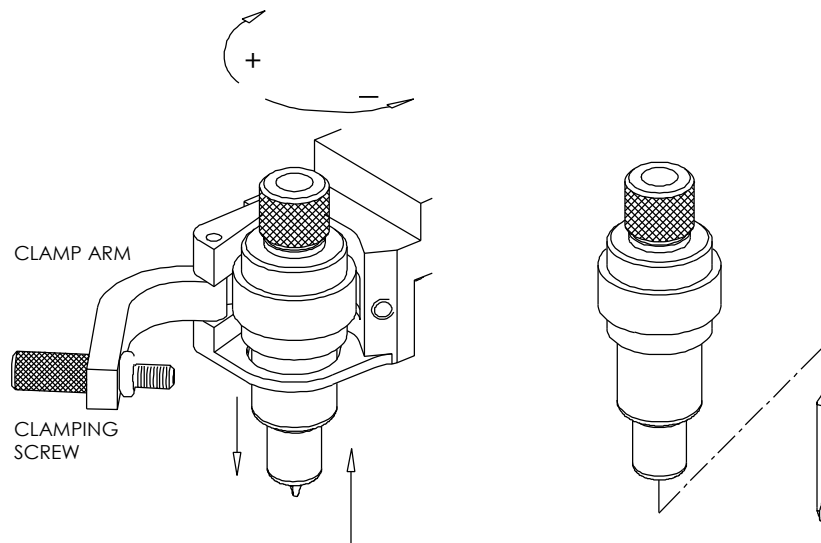

FIGURE 1-6
SETTING KNIFE DEPTH

5. To install the knife into the tool carriage :
 - Loosen the clamping screw, swing the clamp arm back and load the knife.
 - Close the clamp arm and tighten the clamping screw.

6. Set the knife pressure as follows :

- Power up the cutter and load a piece of media in the cutter (See 1.8.). Make sure that none of the two lower LED' s are on. If one LED is on, press on the respective button to turn it off.
- Start up the Summa Cutter Control software on your host PC (See 2.2.). Press the 'Menu' button on the main screen. (For more information about setting up the port parameters, read the help instructions included in the program)
- All the cutter' s parameters will now be displayed. The first one is the knife pressure which can be changed in a range of 0 to 400gr.
- Click the 'Cut Test Pattern' button in the lower right corner to perform a knife depth test as illustrated in Figure 1-7 .

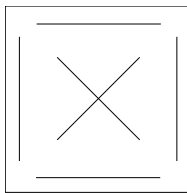

FIGURE 1-7
KNIFE DEPTH TEST PATTERN

The knife depth is correctly set when the test pattern is visible on the front side of the media backing, but not on the rear side of the media backing.

- Click on the 'OK' button to go back to the main window.

In general, you should increase the knife depth and knife pressure when using thicker vinyl types.

7. Analogous to point 6. , the 'knife offset' can be changed (See 2.2.3.).

NOTE

As the ideal knife pressure setting depends upon the thickness and the type of media to be cut, adjusting the knife pressure will require some practice. In general terms, you should increase the pressure when cutting thicker types of vinyl . For thinner types of vinyl, you will normally have to reduce the knife pressure.

**CAUTION**

After setting the cutting depth and/or the knife pressure, perform a thorough visual check of the knife blade, which can be seen protruding from the knife holder, and test cutting results on a scrap of vinyl media.

DO NOT OPERATE THE CUTTER if the knife blade cuts through the media backing, as this will seriously damage the cutter' s rubber cutting strip and the knife.

**CAUTION**

For most vinyl cutting activities, the knife blade tip will be barely visible at the bottom of the knife tool. If you can clearly see the knife blade tip, you will probably need to readjust the cutting depth.

To prevent damage to the cutter, check the depth of the knife blade tip and the quality of the cut each time you load a different type of vinyl into the cutter.

1.7.2. PEN INSTALLATION

The SummaCut cutters can also be operated with a pen. After replacing the knife with a pen, the cutter can be used as a plotter to draw draft plots of new or existing designs on paper.

➔ To install the pen, proceed as follows:

- Load a piece of media in the cutter ([See 1.8.](#)). Make sure that none of the two lower LED' s are on. If one LED is on, press on the respective button to turn it off.
- Start up the Summa Cutter Control on your host PC. Press the 'Menu' button on the main screen. (For more information about setting up the port parameters, read the help instructions included in the program.)

- All the cutter' s parameters will now be displayed. Scroll to the 'Tool' parameter and select 'PEN'.
- Click on the 'OK' button to go back to the main window.
- Analogous to [1.7.1., point 6](#), the pen pressure can be changed.

1.7.3. INSTALLATION OF A POUNCING TOOL

The SummaCut cutters can also be operated with a pouncing tool. After replacing the knife with a pouncing tool, the cutter can be used as a pouncer.

➔ To install the pen, proceed as follows:

- Load a piece of media in the cutter ([See 1.8.](#)). Make sure that none of the two lower LED' s are on. If one LED is on, press on the respective button to turn it off.
- Start up the Summa Cutter Control on your host PC. Press the 'Menu' button on the main screen. (For more information about setting up the port parameters, read the help instructions included in the program.)
- All the cutter' s parameters will now be displayed. Scroll to the 'Tool' parameter and select 'PEN'.
- Click on the 'OK' button to go back to the main window.
- Analogous to [1.7.1., point 6](#), the pouncing pressure can be changed.

1.8. LOADING MEDIA

The following procedures are mainly written for the use of roll media. When using sheets, there are two possibilities. Firstly, when using long sheets, roll up the sheet so that the alignment is identical to that of a roll. Secondly, when using short sheets, the alignment is not so important. If the sheet is cut off perpendicularly, it can be aligned to the front border.

1.8.1. POSITIONING THE PINCH ROLLERS

When working with cut sheet or roll media, the traction resulting from the contact between the pinch rollers and the drive sleeves moves the media in the direction of the X axis (forward/backward).

Proper movement of the media will only occur if the media is driven by the pinch rollers correctly located over two drive sleeves.

The pinch rollers are lowered or raised simultaneously by means of the pinch roller lever arm located on the right hand side of the cutter. The rollers must be lifted to facilitate vinyl loading, during which the media is fed from the rear of the cutter to the front.

When in the up position, the pinch rollers can be moved manually to the left or the right along the pinch roller shaft, so that they can be easily positioned in a detent (click position) where they are to be lowered to ensure optimum traction on the media.

When the pinch rollers are in the up position, the origin LED will flash.

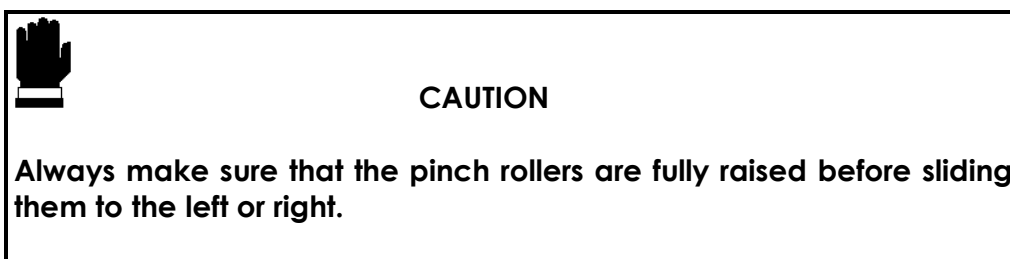

The pinch rollers **MUST** be positioned correctly and lowered onto the media before an automatic load sequence is initiated. Make sure that the two pinch rollers are positioned above the drive sleeves. The left pinch roller should be positioned in a detent (click position). The right pinch roller should be positioned somewhere on the long drive sleeve that only has a click position at the beginning and at the end of the sleeve. The drive drum will move the media only when the pinch rollers are lowered onto the sleeves.

Before lowering the pinch rollers, carefully check the position of the rollers in relation to the drive sleeves. When the pinch rollers are DOWN, the two rollers must run over the sleeves in order to ensure proper media traction. It is very important that both media edges always rest on the sleeves in such a way that the two pinch rollers, which are positioned 3 to 15 mm (0.1" to 0.6") from the media edge, will run over the sleeves when lowered to the drive drum.

1.8.2. FEEDING AND POSITIONING MEDIA

The loading procedure described below has been found to give excellent repeatability. When loading media, adhere to these step-by-step instructions strictly.

→ To load media, proceed as follows:

1. Raise the pinch rollers by means of the pinch roller lever arm located on the right-hand side of the cutter.

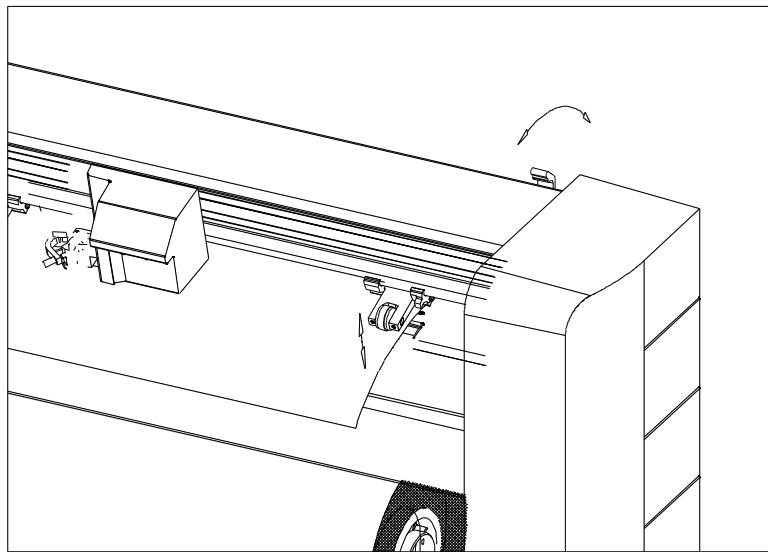

FIGURE 1-8 :
PINCH ROLLER LEVER.

- 2a. When working with roll media and the roll feed, proceed by placing the roll of media horizontally on a table or on another easy-to-reach surface. Make sure that the front edge of the media is at the bottom and pointing away from you. If not, turn the roll. Remove the roll feed from under the machine. Remove the loose core holder. Insert the shaft into the media roll from the right hand side, and press the core holder into the core. Press the shaft further, so that it comes out at the other side of the roll. Insert the loose core holder from the left hand side. Place this assembly back under the cutter.

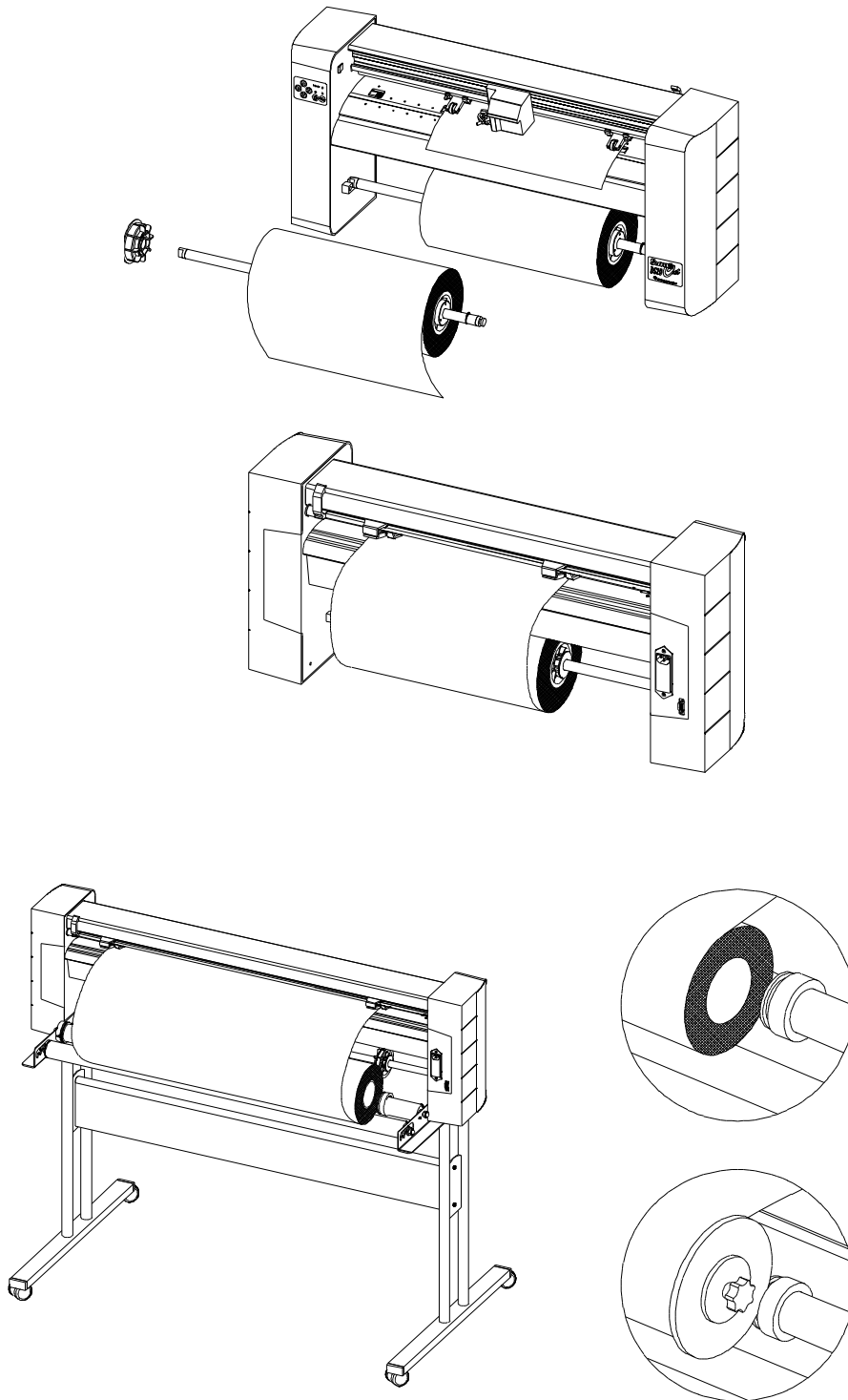

FIGURE 1-9
FEEDING ROLL MEDIA

- 2b. When working with roll media and using the media support system at the back of the machine, proceed by inserting a media flange at each end of the media roll and tighten the thumbscrew until the media roll is firmly gripped between the flanges. Make sure the flanges are firmly pressed against the roll. Place the roll of media on the media support rollers at the rear of the machine.
3. Start feeding the media from the rear of the machine until the front edge of the media reaches the roll again at the front.
Position the left media edge on the left-most drive sleeve and check whether the right media edge is positioned over the long drive sleeve. If so, the left pinch roller can be positioned in a detent (click position) over the left-most sleeve, and the right pinch roller is positioned somewhere over the long drive sleeve to suit the media width. The pinch roller can be lowered anywhere between the two detent (click positions) on the long drive sleeve to allow for flexibility in holding any media width.
In circumstances where the above does not work, because your media is too narrow to reach the long drive sleeve, try positioning the left media edge over the second left drive sleeve, and position the right media edge somewhere on the long drive sleeve.
4. To make sure that the media follows a straight path from the material roll over the platen back to the roll, align the side edge of the media to the roll, and make sure that the media is rolled up properly and follows a straight path.
5. The pinch rollers should be positioned over the drive sleeves about 3 to 15 mm (0.1" to 0.6") away from the media' s outer edges.

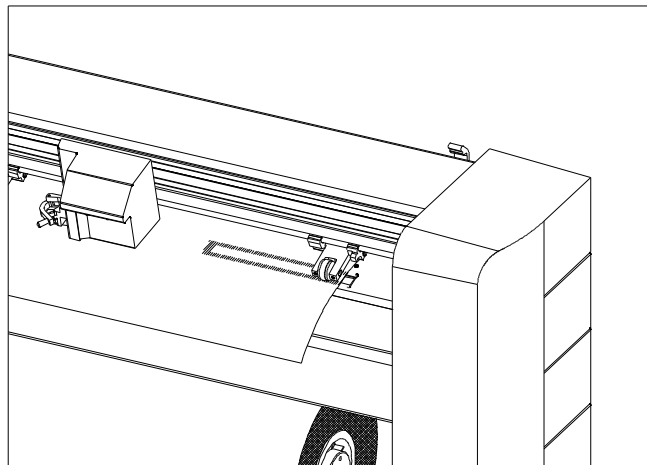

FIGURE 1-10
PINCH ROLLER POSITIONING

6. Lower the pinch roller lever to press the media firmly against the drive sleeves. After one second, the tool carriage automatically moves from the right to the left to sense the usable width.

NOTE

It is not necessary to unroll the media manually from the roll. The cutter will unroll the media automatically during the load sequence.

7. The positioning and routing of sheet material is identical to that of roll media.
8. The cutter is now ready for the actual load procedure.

SECTION 2

OPERATION

2.1. THE CONTROL PANEL

Figure 2-1 shows the control panel of the SummaCut Series cutters. The functions of the control panel keys are explained in the following paragraphs.

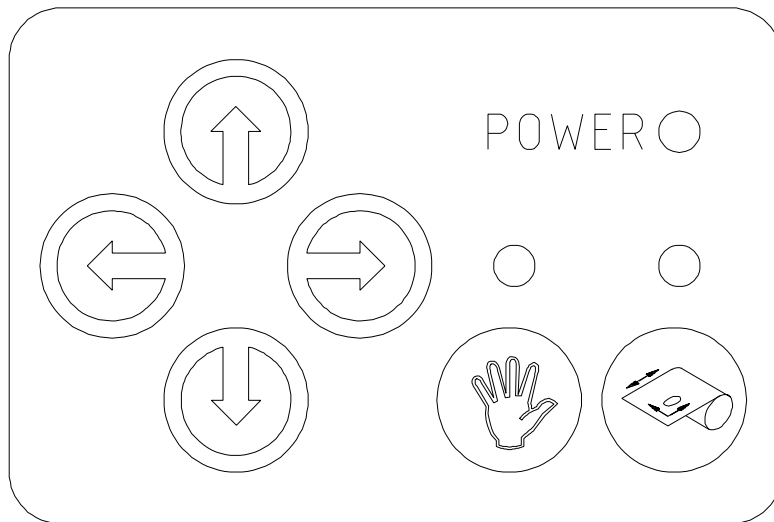









FIGURE 2-1:
SUMMACUT SERIES, CONTROL PANEL





2.1.1. THE ORIGIN KEY





The  key (ORIGIN) is used to move the origin or to abort the cut in progress. When the  key (ORIGIN) is pressed, the cutter goes in Set Origin mode. The current task is aborted and the respective LED will flash on. Move the knife origin using the , , ,  jogging keys and press the  key (ORIGIN) again to confirm the new origin position.



2.1.2. THE ON-LINE KEY

The  key (ON-LINE) toggles between on-line and off-line operation. Selecting OFF-LINE (the respective LED will flash on) will suspend all operations in progress. Pressing the  key while the cutter is off-line will make the cutter go on-line again, resuming the suspended operation.

While the cutter is off-line, the following operations can be performed:

- Press the  or  jogging key to move the tool carriage to the left or to the right.
- Press the  or  jogging key to make the media move forward (towards you) or backward (away from you). Moving the media forward will prove to be very practical when you have to cut the finished sign off manually.

On-line and off-line are two important concepts when using the SummaCut cutters.

When on-line, the cutter can be addressed by the host computer, which means that the cutter will execute cutting or plotting instructions issued by the host computer' s application software. The host computer will first issue a SELECT sequence to the on-line cutter.

When the cutter is on-line and ready to receive instructions from the host computer, it will remain deselected until actual instructions from the computer are received.

For normal cutting operations, the cutter **MUST** be on-line, so that it can receive instructions from the host computer and the cutting/plotting software.

To set the cutter on-line so that it can be selected by the host computer, the following conditions must be met:

- The cutter must be powered up.
- Media must be loaded. For detailed media loading instructions, see [Section 1.8](#).
- The proper tool must be installed.
- The cutter must be connected to the host computer via a RS-232-C link.
- The cutter must be configured for the scheduled operation.

To put the cutter off-line, press the  key. Pressing this key will suspend the current cutting/plotting operation until the cutter is put on-line again.

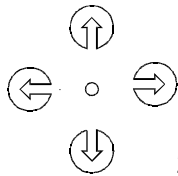

2.1.3. THE JOGGING KEYS

The Jogging keys are used to move the head and vinyl in off-line mode and in Set Origin mode.

2.1.4. LED INDICATORS

The SummaCut has 3 LEDs on its keypad, each of which can be in three different states : ON, OFF or FLASHING. Any combination of LED states represents an error code. See table below.

POWER LED	OFF-LINE LED	ORIGIN LED	Status
[X]	[]	[]	Cutter is online, ready to receive data.
[X]	[]	[*]	Cutter is loading media, or waiting for media to be inserted, or waiting for camrollers to be closed. When the sensors are not working, this key code will be shown.
[X]	[*]	[]	The motor is hot and waiting to cool down.
[X]	[]	[X]	The Load key has been pressed and the cutter is now in "Set Origin" mode, press the arrow keys to place the origin and then press the LOAD key again to set the origin and to return to on-line mode.
[X]	[X]	[]	The Online key has been pressed and the cutter is now in off-line mode, press the arrow keys to move the media and press the ON-LINE key again to return to on-line mode.
[*]	[]	[]	Low Line Voltage error.
[*]	[*]	[*]	High Line Voltage error.
[*]	[]	[*]	X error position.
[*]	[*]	[]	Y error position.
[*]	[X]	[X]	Internal error (=division by zero, bus error, bad command, ...).
[*]	[]	[X]	NVRAM FAILURE, It is then still possible to work with the cutter, but the cutter has been defaulted to a D610. As the nvram has been defaulted to a D610, the margins and the calibration will be incorrect! The correct machine type can be set with SummaCutter Control. Calibration and margins will then also be reset.
[X]	[X]	[X]	Other errors (most of the time a hardware error ,bad ROM or bad RAM.

[] LED off ; [X] LED on; [*] LED flashing.

TABLE 2-1:
LED INDICATION

2.1.5. BOOT KEYS

The SummaCut has some internal boot tests.

To activate these boot tests press, while powering on the unit, the corresponding key on the control panel until the power LED flashes or repeated beeps are heard. Then release the key, and the selected test will be activated.



left key: activates the MENU PLOT. Make sure that an A3 format paper is loaded and that the pen is installed. The MENU PLOT is a hard copy of the present cutter configuration, i.e. the items selected in the USER CONFIG submenus. The plot is organised by menu categories to show the current values for the various USER CONFIG 1 (->4) configurations.

NOTE

It is strongly recommended to produce a MENU PLOT hard copy each time you alter the cutter configuration. The resulting plot should be kept with the cutter documentation in order to provide other users with details of the actual configurations of the unit.



right key : activates the Din Test. Make sure that some media is loaded in the unit. The DIN CUT also performs an electrical and mechanical test of the cutter, in order to check the cut quality, but also provides the user with feedback on knife setting, knife pressure, knife offset and cutting depth.

This cut is always run as a DIN A4 portrait/A-size image, regardless of the actual size of the media loaded. If the media loaded is smaller than DIN A4/A-size, part of the outer box will be clipped (not cut). This cut is always executed in the sequence prescribed by the ISO DIN standard.

2.2. SUMMA CUTTER CONTROL

All the settings of the SummaCut Series can be changed with the control program Summa Cutter Control. For information on installation or general setup of this program, refer to the 'Readme.txt' file on the installation disk.

This program will only communicate with the cutter if the cutter is in on-line mode. This means that the two green LEDs are off.

By clicking on the 'Menu' button in the main Summa Cutter Control window, all the cutter' s settings can be changed.

Four different user configurations can be saved in the cutter' s memory. The selected configuration number is marked at the bottom of the menu window. These four configurations are maintained independently.

Following parameters can be changed with Summa Cutter Control:

2.2.1. KNIFE PRESSURE

The KNIFE PRESSURE parameter is used to set or modify the cutting pressure of the knife.

The default knife pressure value is 120 grams.
The knife pressure can be set between 0 and 400 grams.
The knife pressure value is set in 5 gram increments.
Knife pressure setup is explained in detail in [section 1.7.1](#).

2.2.2. POUNCING PRESSURE

The POUNCING PRESSURE submenu is used to set or modify the pouncing pressure of the pouncing tool.

The default pouncing pressure value is 120 grams.
The pouncing pressure can be set between 0 and 400 grams.
The pouncing pressure value is set in 5 gram increments.
On the LCD, the active pouncing pressure value is marked with an *.
Pouncing pressure setup is explained in detail in [section 1.7.3](#).

2.2.3. KNIFE OFFSET

The KNIFE OFFSET parameter is used to set or modify the distance between the knife blade tip and the centre axis.

The default knife offset value is .45 mm.

The value can be set between 0 and 1 mm.

Make sure that the selected knife offset value matches that of the knife. Some fine tuning may be necessary because of the mechanical tolerances on the knife. To verify the knife offset, a test can be cut by clicking on the 'Cut test pattern' button.

If the offset value is set too low, the rectangles will not close.

When the offset value is set too high, the rectangles will be distorted.

The offset test is illustrated below.

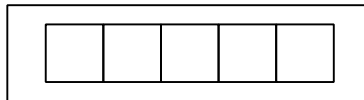

2.2.4. POUNCING GAP

The pouncing gap submenu is used to set or modify the distance between the pounced wholes. This routine applies to the pouncer only.

The default pouncing gap value is 0 mm.

The value can be set between 0 and 50 mm.

On the LCD, the active pouncing gap value is marked with an *.

2.2.5. VELOCITY

The VELOCITY is used to set or modify the velocity of the tool.

The default velocity is 500 mm/s (20 ips).

The velocity can be set between 50 mm/s (2 ips) and 600 mm/s (24 ips).

2.2.6. OVERCUT

The OVERCUT parameter enables you to generate an overcut in order to facilitate weeding of the cut.

The default overcut is set to 1.

The overcut setting can be disabled (=0) or set to any value between 0(=off) and 10. One unit is about 0.1 mm or 0.004".

2.2.7. CONCATENATION

The CONCATENATION feature increases the speed and quality with which cut data having a very high resolution is cut. However, when changing over to normal characters again, deactivate concatenation by setting this parameter to 0.

2.2.8. SMOOTHING

The SMOOTHING feature helps to cut smoother curves when curve data with many short vectors is received from the computer.

The default setting is OFF.

2.2.9. LANGUAGE

The LANGUAGE parameter is used to select the active cutting/plotting language for the cutter.

The SummaSign cutters support DM/PL , HP-GL and HP-GL/2.

NOTE

The active cutting/plotting language MUST match the cutting software.

Always select a language which is supported by the host computer' s cutting software.

Whenever possible, select the DM/PL menu option to set the active cutting/plotting language to Houston Instrument Digital Microprocessor/Plotting Language (DM/PL). This selection will allow the cutter to operate with DM/PL-based cutting/plotting software. This language, having special command extensions for cutting, normally gives superior cutting performance.

Select the HP-GL menu option to set the active cutting/plotting language to HP-GL. The cutter will emulate an HP model 758xB plotter (with selectable origin, [see 2.2.15](#)).

2.2.10. TOOL

The TOOL submenu is used to select the default tool at power up.

To configure the cutter for plotting operations, select PEN.

To configure the cutter for cutting operations, select the DRAG KNIFE option.

To configure the cutter for pouncing operations, select the POUNCING TOOL option.

2.2.11. ADDRESSING

The ADDRESSING parameter is used to select the cutter' s default DM/PL user-addressable resolution. In HP-GL & HP-GL/2 the addressing is fixed at 0.025 mm.

The default addressing resolution is 0.025 mm (Europe) or 0.001" (US).

The user-addressable resolution can be set to 0.025 mm or 0.001" or 0.1 mm or 0.005".

2.2.12. BAUD RATE

The BAUD RATE parameter is used to set or modify the operating baud rate for RS-232-C serial communications between your cutter and the host computer.

The default baud rate is 9600 bps.

The baud rate can be set to any of the following values: 2400 bps, 4800 bps, 9600 bps, 19200 and 38400 bps.

NOTE

The baud rate setting of your cutter **MUST** match the host computer' s baud rate setting.

2.2.13. PARITY

The PARITY submenu is used to set or modify the byte format and parity type for RS-232-C serial communications between your cutter and the host computer.

The default parity setting is bit 8 = 0 (8 data bits, no parity, the 8th bit being a low bit). The parity can be set to any of the following values:

information	Parity setting	Remarks
BIT 8 = 0	8 data bits, no parity	bit 8 = low (0)
BIT 8 = 1	8 data bits, no parity	bit 8 = high (1)
EVEN	7 data bits, 1 parity bit	parity bit = even
ODD	7 data bits, 1 parity bit	parity bit = odd

NOTE

The parity setting of your cutter **MUST** match the host computer' s parity setting.

2.2.14. RTS/DTR

The RTS/DTR submenu controls the Request To Send (RTS) and Data Terminal Ready (DTR) signals of the cutter' s RS-232-C serial communications interface for hardware handshaking.

The RTS/DTR default value is TOGGLE.

RTS/DTR can be set to TOGGLE (hardware handshaking) or HIGH (software handshaking).

2.2.15. HP-GL ORIGIN

The HP-GL ORIGIN parameter will only be displayed if the PLOT LANGUAGE is set to HP-GL. (See Paragraph 2.2.9.) The HP-GL ORIGIN submenu is used to set the origin in the centre (see HP-GL 758x) or in the bottom-right corner (see HP-GL 7475) of the media loaded.

The HP-GL ORIGIN option can be set to RIGHT_FRONT or CENTER.

If the cut is found to be incomplete, and is wholly located in the upper left corner of the media, then modify the HP-GL ORIGIN setting to RIGHT FRONT. If the cut is found to be incomplete, and is wholly located in the lower right corner of the media, then change the HP-GL ORIGIN setting to CENTER.

2.2.16. MEDIA SENSOR

The MEDIA SENSOR parameter is used to activate or deactivate the media sensors.

The sensors detect whether media is loaded, or detect the end of media. The sensors prevent damage to the cutting strip and knife tip.

2.2.17. AUTOLOAD

The AUTOLOAD option enables the user to the change the vinyl unroll proceedings. When AUTOLOAD is ON , the cutter will automatically unroll the vinyl when needed. When the AUTOLOAD option is OFF, the operator himself should unroll enough media before starting to cut.

The default setting is ON. The best results and performance are guaranteed when using this setting.

2.2.18. TOOL COMMAND

The TOOL COMMAND is used to determine whether the DM/PL and HP-GL pen/knife-select commands (the P and SP commands respectively) are ignored or accepted.

When the TOOL COMMAND option is set to "ACCEPT", the P or SP commands will change the selected tool in the cutter according to the suffix that follows the pen/knife command. However, the pen must already have been inserted before because the cutter will not stop when receiving this command. When the TOOL COMMAND option is set to "IGNORE" the pen/knife commands are ignored.

The default setting is "ACCEPT".

2.2.19. LOAD ON W CMD

The LOAD ON W CMD parameter will only be displayed if the PLOT LANGUAGE is set to DM/PL ([See Paragraph 2.2.9.](#)). The LOAD ON W CMD determines, when receiving the DM/PL Window-command (W-command), whether aside from the scaling function, media is loaded or not. Besides scaling, the W-command is also very useful when cutting long signs. With the W-command, media loading will go smoother. Sufficient media will be pulled off the roll at once. Even when AUTOLOAD is off, there is no need anymore to unroll the media manually.

2.2.20. FLEX-CUT

FLEX-CUT can be set to OFF, to Mode 1 or Mode 2. When the cutter is set to Mode 1 or Mode 2, it will alternately cut one length with full pressure, and one length with reduced pressure. The feature FLEX-CUT offers the advantage that it cuts completely through the material, yet allowing the material to stay together by means of the small media bridges.

MODE 1 is the quickest mode, but it is less precise because the pressure changes during the cutting. MODE 2 is a lot slower, but at the same time it is much more precise, as the cutter stops at every change of pressure.

2.2.21. CUT LENGTH

This parameter determines the length that is cut with full pressure. By clicking on the 'Cut Test Pattern' button, the FLEX-CUT test pattern will be cut.

2.2.22. FLEX CUT LENGTH

This parameter determines the length that will be cut with reduced pressure or without pressure. By clicking on the 'Cut Test Pattern' button, the FLEX-CUT test pattern will be cut.

2.2.23. FLEX PRESSURE

This parameter determines the pressure of the FLEX-CUT LENGTH. By clicking on the 'Cut Test Pattern' button, the FLEX-CUT test pattern will be cut.

2.2.24. RECUT OFFSET

The recut offset submenu is used to set or modify the distances between the drawings when making multiple recuts.

The default recut offset value is 0 mm.

The distance can be set between 0 and 255 mm.

On the LCD, the active recut offset value is marked with an *.

2.2.25. RECUT

The Summa Cutter Control program also offers the possibility to recut the last file sent to the cutter (provided that it fitted into the buffer).

To make a recut, proceed as follows:

1. Cut the file once with your usual software.
2. Start up the Summa Cutter Control program. Make sure that the port is correctly configured.
3. Press the Recut button.
4. Select the desired number of copies and the recut offset

SECTION 3

GENERAL INFORMATION



3.1. MAINTENANCE & CLEANING

The SummaCut cutter range has a number of sliding surfaces made of smooth metals and plastics. They are virtually friction-free and require no lubrication. They will, however, collect dust and lint which may affect the performance of the cutter. Keep the cutter as clean as possible by using a dust cover. When necessary, clean the unit with a soft cloth dampened with isopropyl alcohol or mild detergent. Do not use abrasives.

3.1.1. CLEANING THE DRIVE SYSTEM

After a time, the sleeves of the drive drum may become clogged with accumulated residue from the media. This situation may affect traction as the media will tend to slip between the pinch rollers and the drive sleeves.

➔ To clean the drive sleeves, proceed as follows:

1. First disable the sensors by covering them, or via the configuration menu.
2. Place the cutter off-line. Local operation will allow you to use the control panel jogging keys, even when no media is loaded.
3. Remove the backing from a piece of vinyl. Place the vinyl with the tacky side down between one of the pinch rollers and a drive sleeve. Lower the pinch roller arm.
4. Use the  and  jogging keys to move the piece of vinyl backward and forward several times, until all residue is removed from the drive sleeves.
5. Raise the pinch roller arm and remove the piece of vinyl media.
6. Repeat steps 3 through 5 for the other drive sleeves.

7. Set the cutter's power switch to OFF.

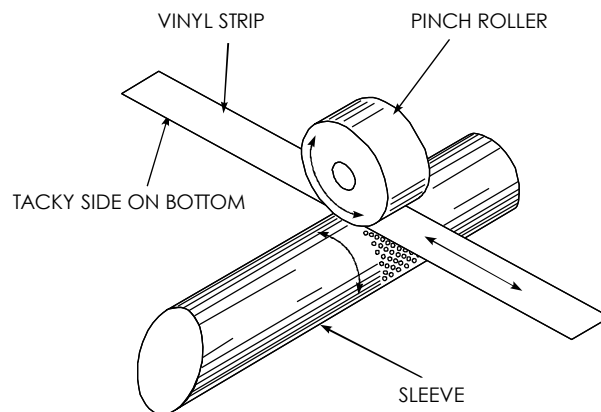

FIGURE 3-1:
CLEANING THE DRIVE SLEEVES

3.1.2. CLEANING THE SENSORS

After a certain time, the sensor may become dirty with accumulated residue from the media. This situation may cause malfunctioning of the cutter.

➔ To clean the sensor area, proceed as follows:

1. The sensors are located on the cutter's right side. One sensor is located on the front platen; the other sensor is located on the rear platen.

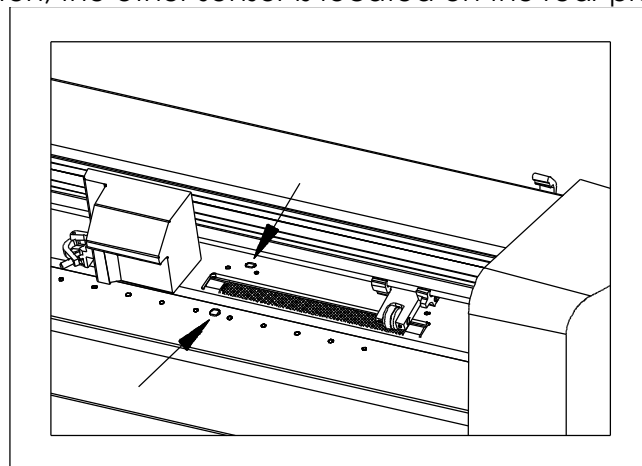

FIGURE 3-2:
LOCATION OF THE SENSORS

2. To keep the sensors clean, it is sufficient to wipe them out now and then with a cotton swab.

3.2. OPERATING VOLTAGE CONVERSION

The power entry module cover shows four possible AC voltage settings (100 V, 120 V, 220 V and 240 V). The pin in one of the holes indicates the cutter's active voltage setting. If this setting does not match the voltage supplied to your site, you must change the voltage **BEFORE** powering on the cutter.

When changing the voltage setting, you will also have to change the fuses as appropriate to the voltage.

To change the fuse(s), remove the fuse(s) from the fuse box behind the cover plate of the power entry module.

For 100 or 120 V AC operation, use only 1.0 A Slo-Blo fuses in case of the D520, D620 and the D760 SummaCut models.

For 220 or 240 V AC operation, use only 0.5 A Slo-Blo fuses in case of the D520, D620 and the D760 SummaCut models.

For 100 or 120 V AC operation, use only 1.25 A Slo-Blo fuses in case of the D1020 and D1220 SummaCut models.

For 220 or 240 V AC operation, use only 0.6 A Slo-Blo fuses in case of the D1020 and D1220 SummaCut models.

NOTE

Always make sure that you are using the correct fuses for your voltage selection.

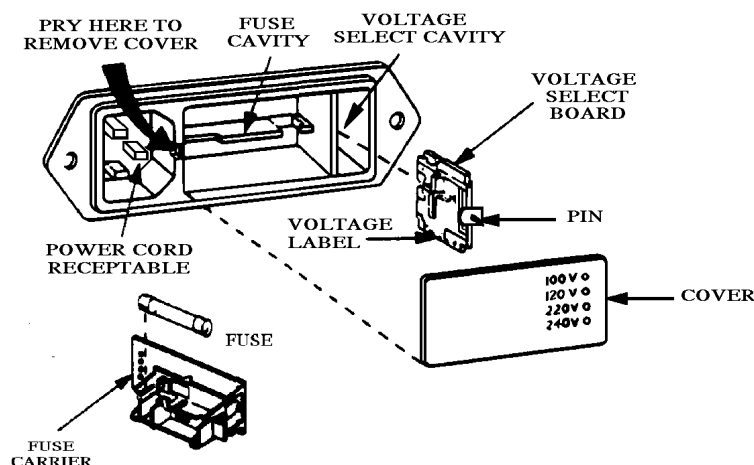

FIGURE 3-3
POWER ENTRY MODULE

SECTION 4

INTERFACE

4.1. INTRODUCTION

This section describes the signal connections for RS-232-C serial communication between your cutter and the host computer. When connecting the cutter to the host computer, always proceed as follows:

1. Refer to the cutting/plotting application software documentation and check the recommended cabling specifications.

If your cutter is not specifically listed, use the cabling specified for the Houston Instrument DMP-60C cutters.

2. If the documentation of the cutting/plotting software does not contain specific cabling instructions, use the Summagraphics cable specifications recommended for your computer.

4.2. INTERFACE NOTES

4.2.1. SYSTEM SETUP

4.2.1.1. MS-DOS or PC-DOS operating system

➔ To set up your system, proceed as follows:

1. Boot up the operating system.
2. If the cutter is to be connected to serial port #1 (known as COM1) the port must be configured by entering the following command at the system prompt: MODE COM1:9600,N,8,2,P.
3. If the cutter is to be connected to serial port #2 (known as COM2) the port must be configured by entering the following command at the system prompt: MODE COM2:9600,N,8,2,P.

4. To redirect the output to serial port #1, enter the following command at the system prompt: MODE LPT1:=COM1:.
5. To redirect the output to serial port #2, enter the following command at the system prompt: MODE LPT1:=COM2:.
6. The computer end of the cable must be plugged into the serial port defined as COM1 (or COM2). The cutter' s baud rate must be set to 9600, with parity NONE and RTS/DTR mode set to TOGGLE.

4.2.1.2. Windows 3.xx.

➔ To set up your system, proceed as follows:

1. Select "Main group" in the Program Manager. Select "Control Panel", then "Ports" and then the port that is connected to the cutter. Press the "Settings" Button to see the port settings.
2. The default settings of the cutter are as follow:
 - Baudrate : 9600 (see 2.2.12.)
 - Data Bits : 8
 - Parity : none (see 2.2.14.)
 - Stop Bits: 2
 - Flow Control : Hardware or Xon / Xoff

4.2.1.3. Windows 95

➔ To set up your system, proceed as follows:

1. Press the "Start" Button and select "Settings", continued by "Control Panel". Press on the "System" icon and select the "Device Manager" tab. Select the port that is connected to the cutter and click on the properties button. Select the "Port Settings" tab to set the port settings.
2. Analogous to 4.2.1.2.

4.2.2. SERIAL INTERFACE CONNECTOR ON CUTTER

RS-232C Serial Interface Connector		
<i>Pin n°</i>	<i>Signal</i>	<i>Description</i>
1	NC	Not Connected
2	RXD	Receive Data
3	TXD	Transmit Data
4	DTR	Data Terminal Ready
5	GND	Signal ground
6	NC	Not connected
7	RTS	Request To Send
8	CTS	Clear To Send
9	NC	Not Connected

4.3. AVAILABLE SERIAL SIGNALS

If you are making your own cable, only a few of the cutter pins will actually need to be connected to the host computer. To ensure optimum results, the cable length should not exceed 4.8 m (16 feet). It should be taken into account that your computer or cutting software may also require additional loopback connections at the host computer' s end of the data cable.

- Connect the Transmit Data (TXD) pin of the computer to pin #2 of the cutter.
- Connect the Receive Data (RXD) pin of the computer to pin #3 of the cutter.
- For hardware handshaking, connect the Clear To Send (CTS) pin of the computer to pin #4 or pin #7 of the cutter. Connect the Request To Send (RTS) pin of the computer to pin #8 of the cutter.
- Connect the ground (GND) pin of the computer to pin #5 of the cutter.

5 Contour cutting on the SummaCut Series

5.1. INTRODUCTION

The SummaCut Series cutters have accurate alignment methods to guarantee precise contour cutting.



Depending on the selected alignment method, the cutters can counterbalance the following irregularities:

1. ROTATED DESIGN : If the printed design is not loaded straight into the unit, the contour can be rotated equally to fit the printed graphic.

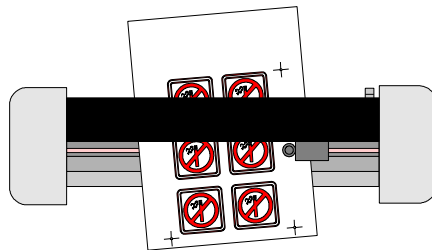

2. SKEWED DESIGN : If the X and Y axes of the printed design are not perpendicular, the contour can be skewed to fit the printed design.

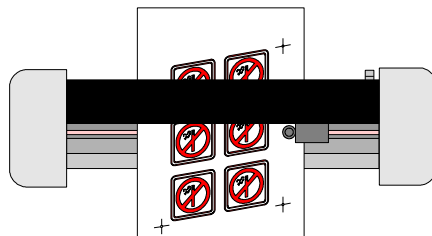

3. INCORRECTLY SCALED DESIGN : If the print size is different from the original design in your software due to media expansion or shrinkage, or due to printing inaccuracies, the contour can be scaled to fit the printed graphic.

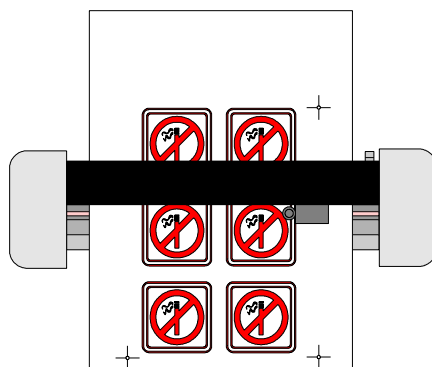

NOTE : The scaling can only be adjusted by a few percent.

→ Any combination of the three above irregularities can be handled too.

The parameter SPECIAL_LOAD in the user configuration menu determines which alignment method is used. Use SummaCutter Control to select the desired alignment method:

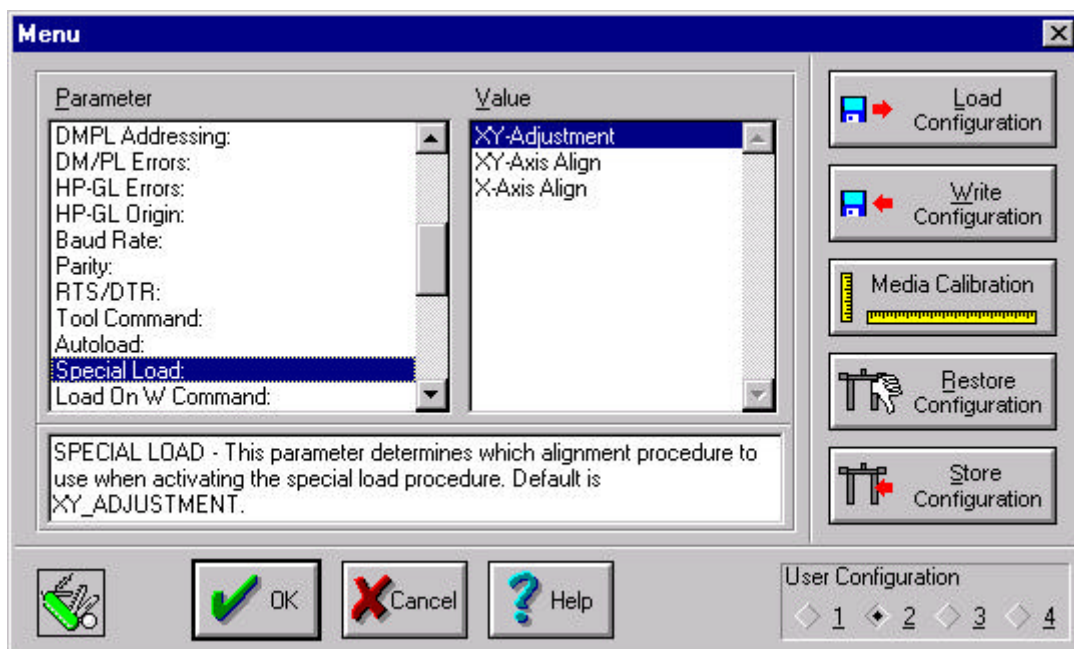
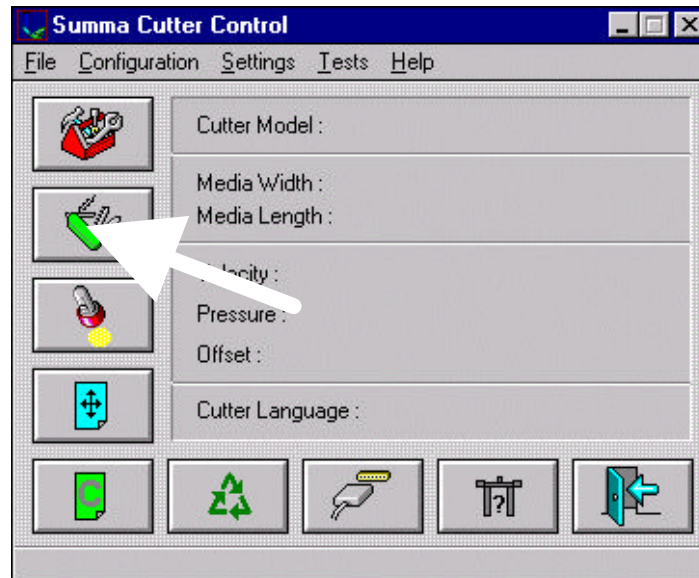

The alignment methods are based on the principle of cross-marks that are printed together with the drawing. These cross-marks can be of any type.

There are three alignment methods.

Alignment methods:

1. **X-Alignment** : counterbalances a "rotated design" problem. For this method, the origin and one point along the x-axis must be specified. This method only rotates the contour. It does not require any distance parameters. This is the fastest and easiest method. It is advised to use this method with small sheets (up to A3 (11" x 17")).

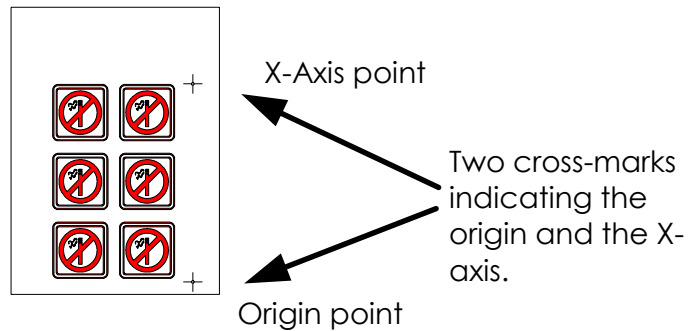

2. **XY-Alignment** : counterbalances the "rotated design" and "skewed design" problems. For this method, the origin, one point along the x-axis and one point along the y-axis must be specified. This method rotates and skews the drawing. It does not need any distance parameters. This method is the most precise method without using any distance parameters.

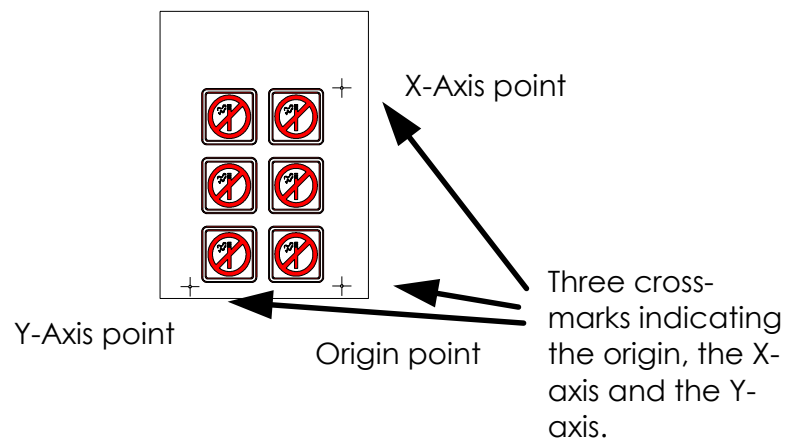

3. **XY-Adjustment** : counterbalances the "rotated design", "skewed design" and "Incorrectly scaled design" problems. For this method, the origin, one defined point along the x-axis and one defined point along the y-axis must be specified. This method rotates, skews and scales the drawing. It requires two parameters ($x_distance$ and $y_distance$). These distances define the position of the two points along the axes. This is the most accurate manual alignment method.

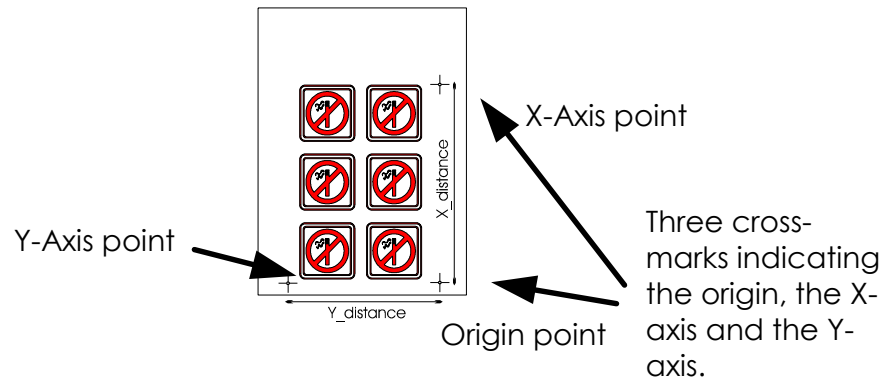

5.2. GENERAL (see section 6 for the actual procedure details)

For accurate Contour Cutting with the alignment methods, proceed as follows:

- Create the design on which you want to perform the contour cut.
- Place cross-marks around your design.
- Print out the design with the cross marks.
- Load the printed design in the cutter and set the cross-mark parameters in the cutter (only when using the XY-adjustment method).
- Execute the special load procedure.
- Cut out the contour.

5.3. CREATING THE DESIGN

- Create in your software the design you want to print and Cut:



- Define the Contour:

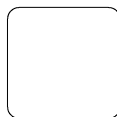

⇒ Do not define the contour exactly on a printed line. This way it will not catch the eye if the contour has moved a little during cutting.



⇒ Place the contour on a separate layer, assign a unique color to it, etc. (refer to your software documentation), so that it is easy to select the contour or the design.

NOTE

Most dedicated sign-making software will provide some easier ways to do all this. Please contact your dealer.

- Make multiple copies if necessary (of both the design and the contour):

**5.4. PLACING THE CROSS-MARKS**

- Place two cross-marks indicating the X-axis.

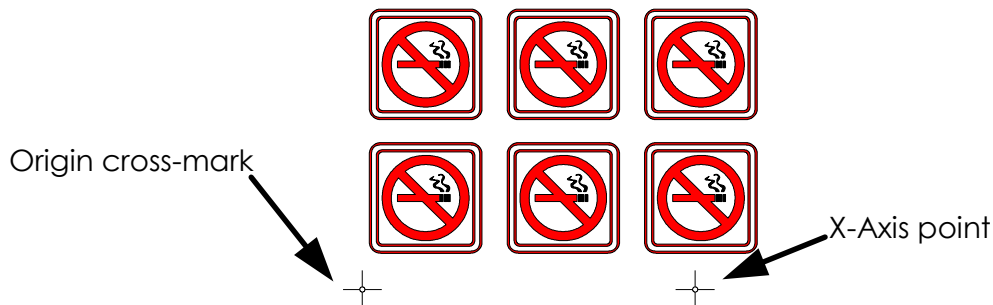

- ◆ Make sure that the origin cross-mark is situated completely at the left side and below all the contours that will be cut.
- ◆ Make sure that the two cross-marks are situated exactly at the same height.
- ◆ The cross-marks may be of any type.
- ◆ The exact distance between the two points that are indicated by these cross-marks must be known (only when using the XY-adjustment method). Do not measure these distances on the print out but measure them in the software!

⇒ Place the markers as far as possible from each other for maximum accuracy.

⇒ Place the cross-marks on a separate layer for easier handling.



- Place the cross-mark indicating the Y-axis (only when using the XY-Alignment and the XY-Adjustment method):

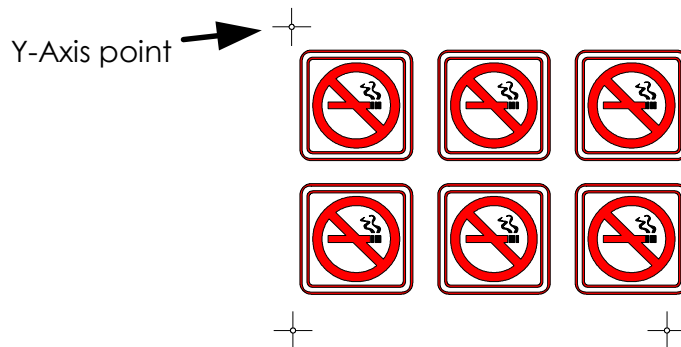

- ◆ Make sure that the cross-mark is placed exactly above the origin marker.
- ◆ The exact distance between the two points that are indicated by this marker and the origin must be known (only when using the XY-Adjustment method). Do not measure these distances on the print-out, but measure them in the software.



⇒ Place the markers as far as possible from each other for maximum accuracy.

5.5. PRINT THE DESIGN

- Print the markers and the design with your printer.
- When printing on a roll, make sure that the orientation is as follows:

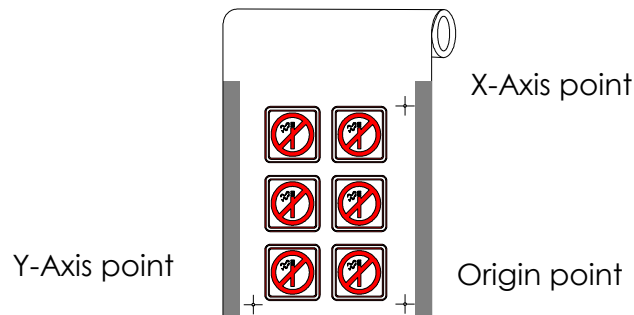

- ◆ Make sure that there is at least 1 cm, preferably 2cm margin (0.4", preferably 0.8") on each side.
- When printing on sheets or cutting off your print from the roll, make sure that there is a margin of at least 8 cm (3.15") at the end of the sheet:

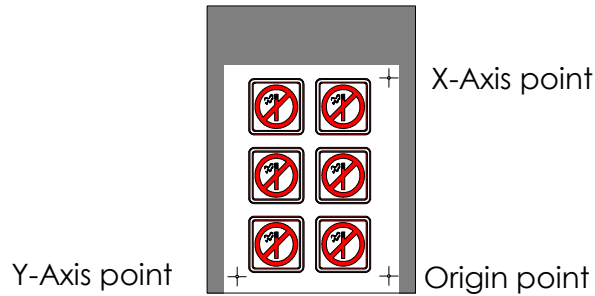

5.6. LOADING THE CUTTER AND SETTING THE PARAMETERS

- Load the print out in the cutter as described in the User's Manual. Make sure that the cross-mark indicating the origin is situated at the front right.

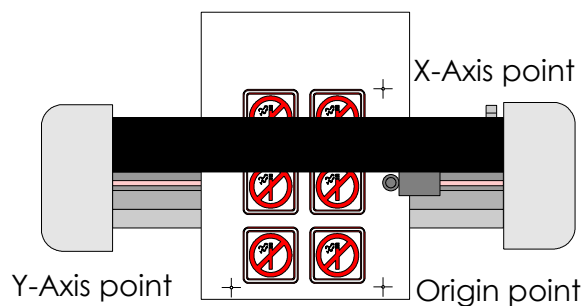



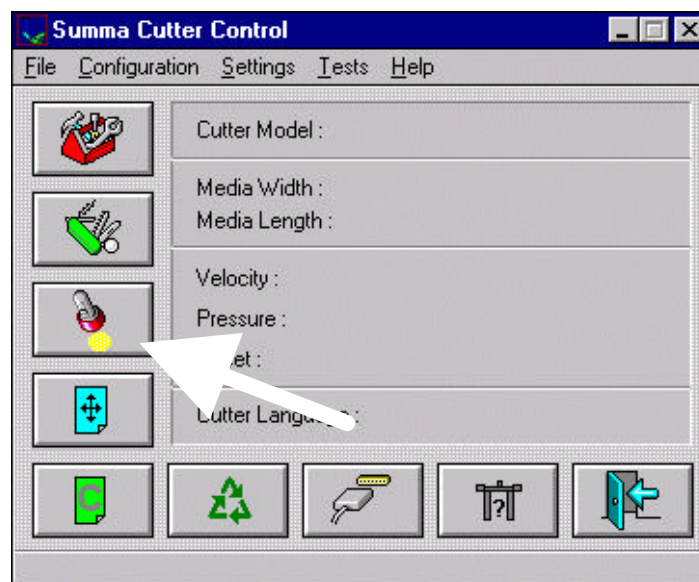

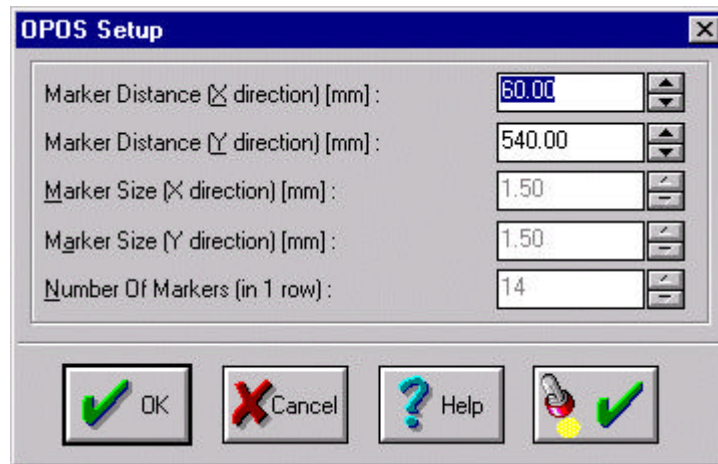

- If you have selected the XY-adjustment method (see above), then open Summa Cutter Control and select OPOS in the Configuration menu.



- ◆ Fill in the values for the marker distances and press OK:



5.7. REGISTRATING THE CROSS-MARKS

- Before proceeding, make sure all the cutting parameters are correct (pressure, velocity, ...). See User's Manual.
- Press the  key. The origin LED will turn green.
- Press the  key . The on-line LED will flash.
- Position the knife tip exactly above the origin-marker using the , , ,  jogging keys.

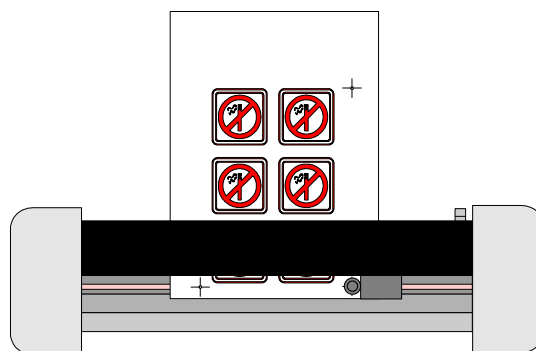

During this entire procedure, make sure that the knife does not rotate, which may cause an offset error.

Indicate the cross-marks with extreme accuracy because it directly influences the result.

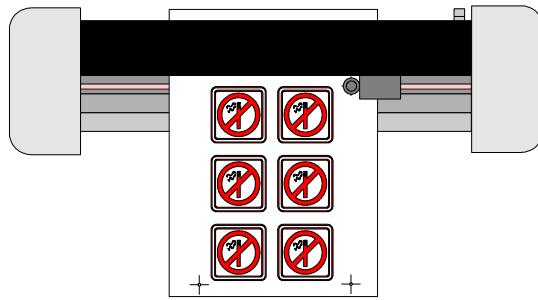

- Press the  key. Position the knife tip exactly above the mark indicating the X-axis.



- Press the  key . If the X-axis-alignment method has been chosen, the special load procedure will stop here. For the two other methods: position the knife tip exactly above the cross-mark indicating the Y-axis. Press the  key .

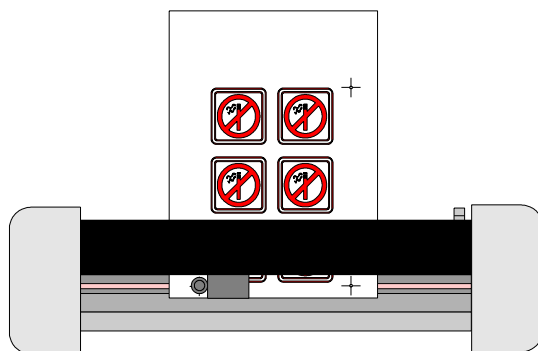

5.8. CUTTING THE CONTOUR

- Follow the specific instructions for contour cutting in your software. If there are no such instructions, follow the explanation below.
- Move the entire design (cross-marks and contours included) in your software so that the origin mark is situated in the lower left corner of the cutting area (In most sign-making software the orientation is landscape. If not, you will have to rotate everything).

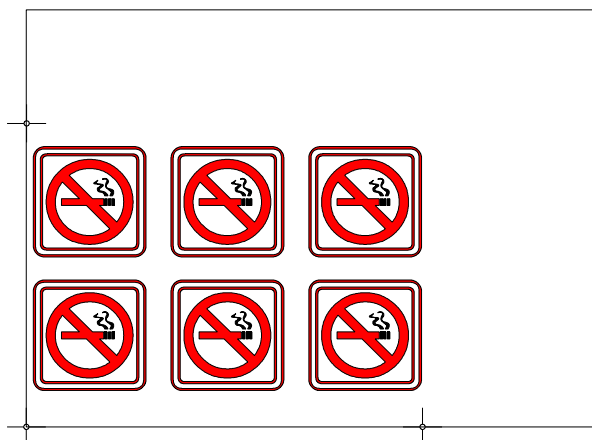

- Select the contours and cut them out:

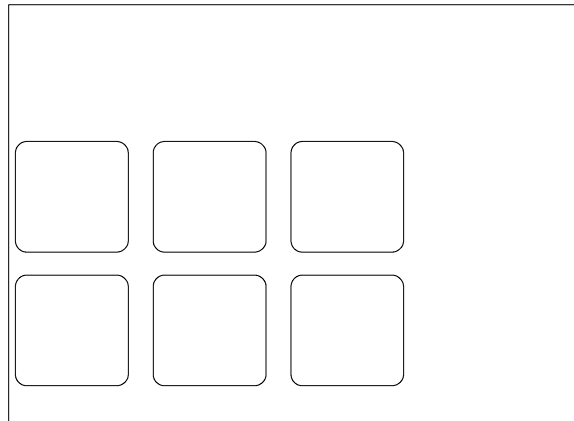

- ◆ Make sure that only the contours are cut.
- ◆ Make sure that the origin of the cutting area is used.



⇒ Some software will shift the selected contours to the origin when cutting. This can be avoided by adding a small rectangle that has its lower left corner right in the origin. Select this rectangle together with the contours.

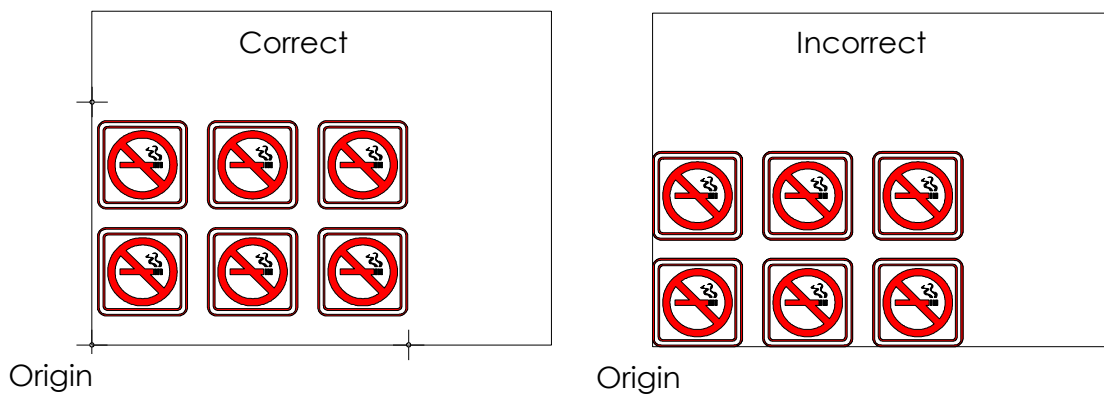

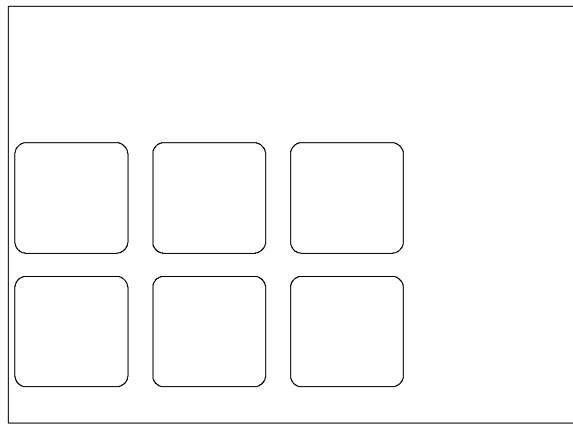

- ◆ Make sure that only the contours are cut.
- ◆ Make sure that the origin of the cutting area is used.



⇒ Some software will shift the selected contours to the origin when cutting. This can be avoided by adding a small rectangle that has its lower left corner right in the origin. Select this rectangle together with the contours.

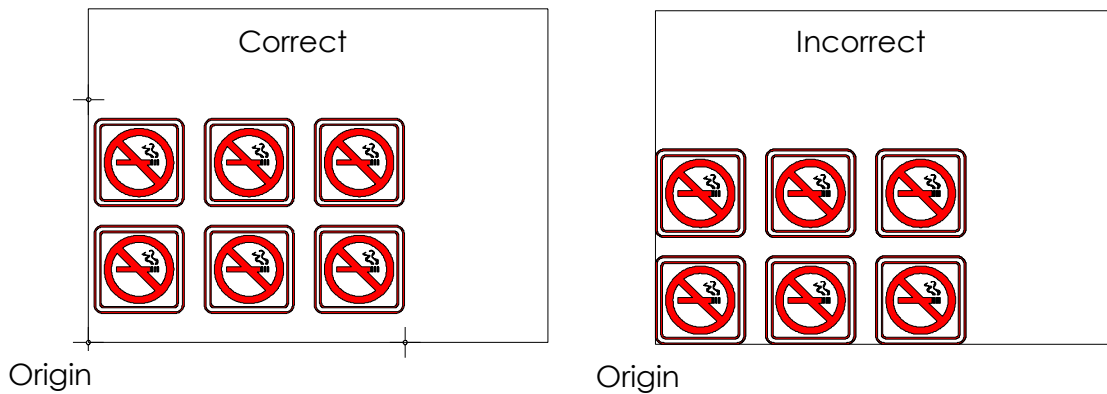

APPENDIX A

MEDIA CERTIFICATION

Types of media

A wide range of vinyl types has been evaluated and extensively tested on the SummaCut Series cutters. To ensure operation in compliance with the functional specifications of the SummaCut cutters as listed in Section 1 of the User's Manual, only duly certified media should be used.

An alphabetic list of all duly certified media is included below. Before using other media, please contact your local Summa representative for advice.

Manufacturer	Type
3 M	Scotchcal Series 100 Scotchcal Series 3480 Scotchcal Translucent Series 3630 Scotchcal Special Effects 210 Controltac Series 170 Controltac Series 180
APA	
ARLON	Series 2100 Series 2500
FASSON	Economy Fascal 900 High Performance Fascal 4500 Translucent Fascal 8800 Intermediate
GRAFITACK	Economy 100 Series 200 - 300 Series Transparent
KAPCO	High Performance Cast Vinyl Intermediate K5000
MACTAC	MaCal 8900 MaCal 9700 MaCal 9800

MULTIFIX	Series 1000 Series 5000 Series 7000
MULTISTIQ	Series 4500 Series 4600 Series 4700
PMF	500-600-700 Series
TESA	Tesacal 4196
X-FILM	Economy

SUMMA ADDRESSES

Americas and Asia Pacific

Summa, Inc.
372 North Billy Mitchell Road
Salt Lake City, Utah 84116
USA
+(01) 801-355-6669 Tel
+(01) 801-355-4446 Fax

Europe

Summa NV
Rochesterlaan 6
8470 GISTEL
Belgium
+32 59 270011 Tel
+32 59 270063 Fax