

GOTM

PRODUCE

User Manual
Rev 008



Notice

Summa reserves the right to modify the information, contained in this User Manual, at any time without prior notice. Unauthorized copying, modification, distribution or display is prohibited. All rights reserved.

Copyright © Summa NV

Contact Information

All inquiries, comments or suggestions concerning this and other Summa manuals should be directed to:

Summa, nv
Rochesterlaan 6
B-8470 GISTEL
Belgium

Website

www.summa.com

Revision history

Version	Reason for modification	Publication date	Author
001	Original version	01 March 2019	-
002	Added changes for GoProduce version 1.7.20	04 September 2019	-
003	Added changes for GoProduce version 1.8.16	06 November 2019	-
004	Added changes for GoProduce version 2.x.x	01 February 2021	W.V.
005	Layout and language revision Updates for release 2.4.0	09 September 2022	A.L.
006	Updates up to and incl. release 2.4.2	07 December 2022	A.L.
007	Updates for release 2.5	02 March 2023	A.L.
008	Updates for release 2.6	September 2023	A.L.

Table of Contents

1	Installation	3
1.1	General.....	3
1.2	Installation	3
1.3	Activation.....	4
1.4	Requesting a trial version	6
2	Standard program.....	7
2.1	Main window	7
2.2	Quick access toolbar.....	8
2.3	Ribbon.....	8
2.3.1	Job tab.....	8
2.3.2	Selection tab	11
2.3.3	Material manager tab	12
2.3.3.1	Materials.....	12
2.3.3.2	Methods	31
2.3.3.3	Camera profiles.....	31
2.3.3.4	Routing bits	34
2.3.4	Devices tab	34
2.3.5	General tab	34
2.4	Action sets	36
2.4.1	General.....	36
2.4.2	List of available actions	37
2.4.2.1	Clean up.....	37
2.4.2.2	Device	37
2.4.2.3	General.....	38
2.4.2.4	Job.....	44
2.4.2.5	Layer	44
2.4.3	Predefined action sets.....	45
2.4.3.1	Tandem mode	46
2.4.3.2	Backside cutting (Legacy action set)	48
2.4.4	Creating action sets	49
2.5	Layer window.....	50
2.5.1	General.....	50
2.5.2	Set materials	51
2.5.3	Set camera profiles	51
2.5.4	Set methods/tool parameters	52
2.5.4.1	Case 1: Material and method set correctly in the cut data file	52
2.5.4.2	Case 2: Material not set correctly / wrong method chosen for material.....	53
2.5.4.3	Case 3: Method is unknown (or not correctly set in the design program)	53
3	Pro Pack.....	54
3.1	General.....	54
3.2	Ability to import other file types	54
3.3	Barcode workflow.....	54
3.3.1	About barcode workflow.....	54
3.3.1.1	Barcode workflow on roll.....	54

3.3.1.2	Barcode workflow on sheet	55
3.4	Twin workflow	55
3.4.1	About Twin workflow	55
3.5	Hot folder support	55

1 INSTALLATION

1.1 General

Summa GoProduce is a software that integrates the flatbed into the workflow. It is the perfect link between the design station, RIP station, printers and cutting devices. Once the workflow is set up, macros automate the process. Consequently, the number of times the operator has to intervene to start the next job is reduced to a minimum, as is the downtime of the machine.



NOTE: The program is copy-protected with a license code. Different license codes can unlock different options in the program.



NOTE: We recommend installing the GoProduce software on a computer that has internet connection. This way, the activation procedure will automatically proceed online and more importantly, it is useful for later servicing. The license key should only be activated offline if the computer is used in a high security environment with no internet connection. In this case, the activation procedure will automatically proceed offline.

1.2 Installation

1. Double-click the installation program to start the setup. Follow the on-screen instructions to complete installation. The following screen appears.

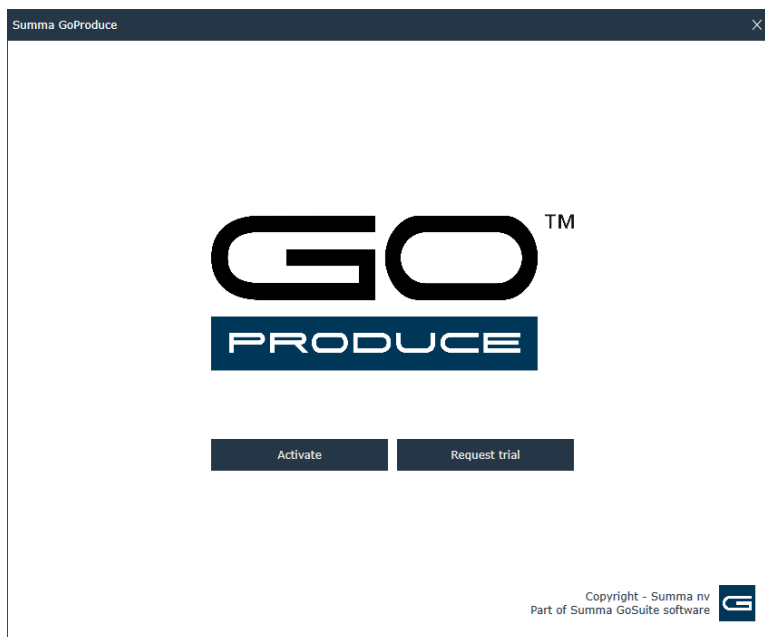

2. Start the activation procedure (see chapter 1.3) or the trial version request procedure (see chapter 1.4) by clicking the corresponding button.



NOTE: You can also do this later from within the software itself ([General](#) > [About](#)).

- When clicking **Activate** to activate the Pro Pack license key, follow the on-screen instructions to complete the procedure.

When activating on an offline computer and the computer cannot connect to the license manager, in one of the activation procedure steps a QR code will appear on the screen:

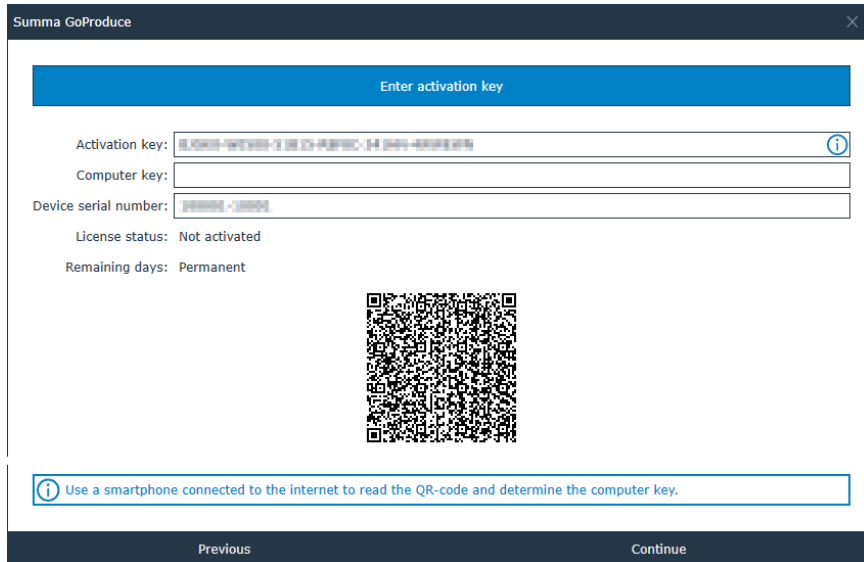

Use your smartphone to scan the QR code and get a computer key that needs to be entered in the window above.

- Complete the activation procedure and click **Continue**. The following screen appears, giving an overview of the licenses.

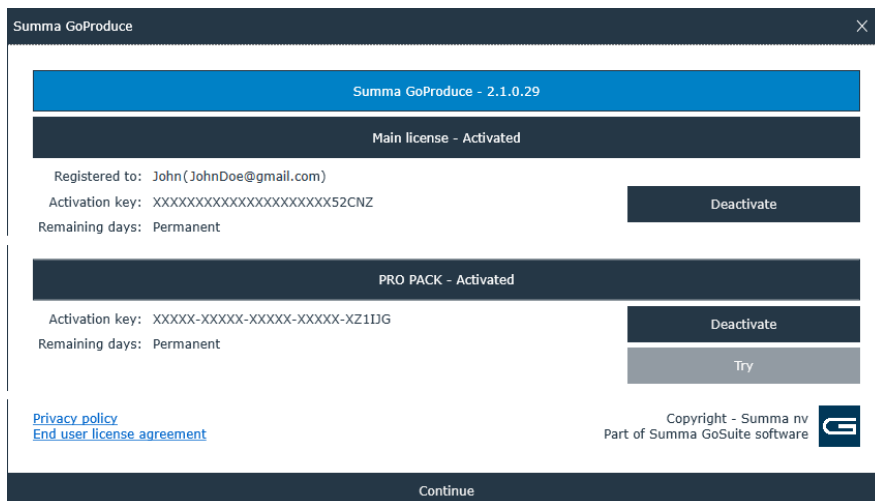

- Click **Continue** to launch GoProduce.

1.4 Requesting a trial version



NOTE: It is assumed that the computer is connected to the internet when activating a trial version license code.



NOTE: The trial license key is linked to the computer. Only one trial version can be installed per computer. It is, however, possible to activate a purchased license code afterwards on that same computer.

1. Click **Request trial**. Follow the on-screen instructions to complete the trial version request procedure.



NOTE: The trial key is sent to you by email.

2. After completing the trial version request procedure, the following screen appears. You can now try the Pro Pack by clicking **Try**.

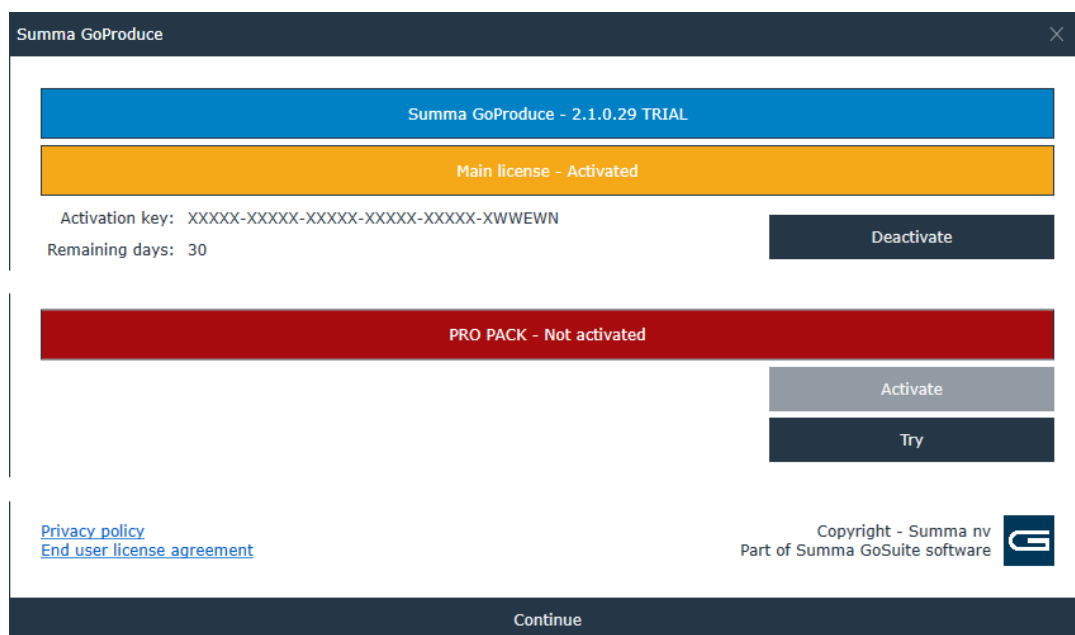

3. Click **Continue** to launch GoProduce.

2 STANDARD PROGRAM



NOTE: When GoProduce communicates with the table, it first checks the firmware revision. If the firmware revision is not compatible with the current version of GoProduce, a message will appear. You will not be able to send any cut data to the table. The cutter firmware needs to be updated first.

2.1 Main window

The window of the program Summa GoProduce consists of four main areas. The ribbon contains five tabs. On the left side, there is a docked window with the action sets. On the right side, there is a docked window with layer information. In the middle, a job preview will be shown. If multiple jobs are opened, they open in docked tabs of the middle window.

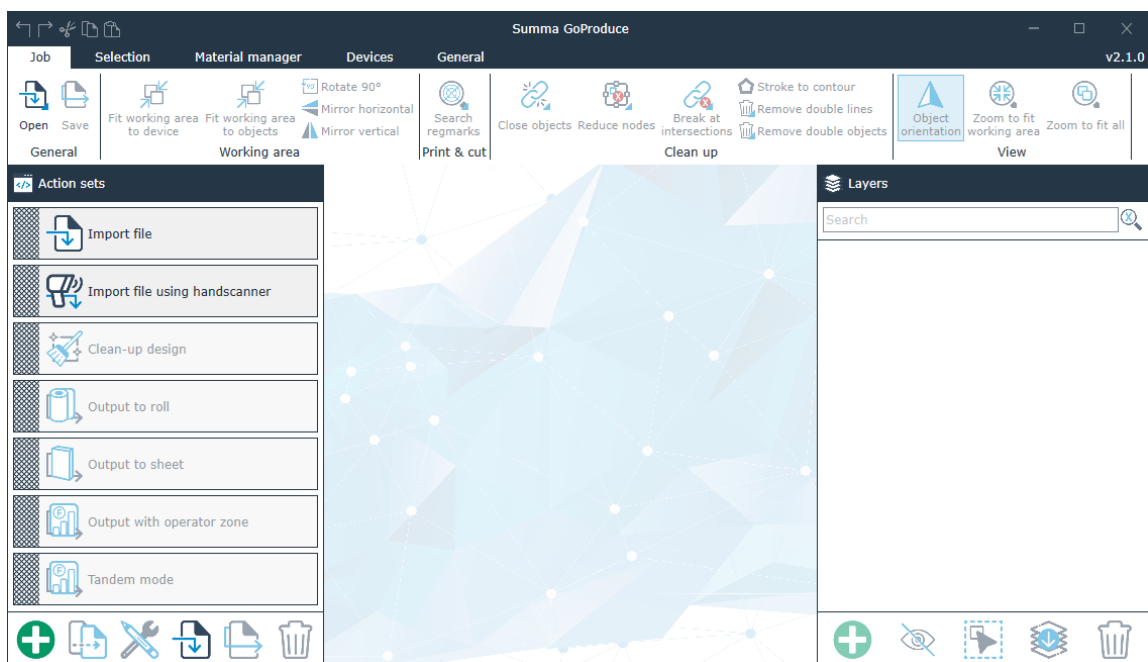

All docked windows can be set floating. To do so, click the window name and drag it to where you want it. There are also keyboard shortcuts that allow you to dock the window left, right, top, bottom or in the rest of the free space.

2.2 Quick access toolbar

The title bar is also the quick access toolbar and includes the following commands: undo, redo, cut, copy and paste.



2.3 Ribbon

The ribbon contains five tabs.

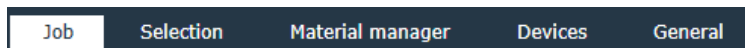

2.3.1 Job tab

This tab contains some basic editing features that can optimize job cutting. Most of those functions can be included in the import action set. A default import action already includes some of these functions. You can create additional specific import actions that also include these features.

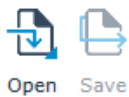

Click **Save** to save a job. They are stored as SGPJ files. Click **Open** to open a job. Jobs include the original cut data that was imported, and settings related to material and tools. Thus, if copies of previous jobs are needed, they can easily be created using the settings used previously.

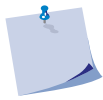

NOTE: The basic version of GoProduce allows importing the following file types:

- SGSJ files (*.sgsj; *.SGSJ)
- PDF files (*.pdf; *.PDF)
- DXF files (*.dxf; *.DXF)
- OXF files (*.oxf; *.oxf2; *.OXF; *.OXF2)
- SGP files (*.sgp; *.SGP)
- SVG files (*.svg; *.SVG)



Export

When the Pro Pack is installed, you can export the job to a PDF file.

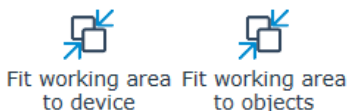

Fit working area to device

Fit working area to objects

Click **Fit working area to device** to reset the working area to the device size. The cutter needs to be connected and the media loaded. Click **Fit working area to objects** to use the bounding box of all your objects as working area.

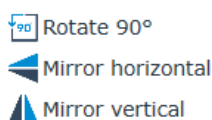

Rotate 90°

Mirror horizontal

Mirror vertical

Click Rotate 90° to rotate the job 90° CCW. Click **Mirror horizontal** or **Mirror vertical** to mirror the job horizontally or vertically. The objects do not have to be selected first; clicking the action automatically selects all objects before the action is performed.



Print & cut

This function searches for the registration marks on certain layers. Usually the registration marks are recognized while importing the file. In some cases, however, additional registration marks may have been added on special layers or the file to be imported may not have been prepared correctly. In that case, this function can be used to scan each layer for registration marks. First, right-click on the icon. A settings window will open.

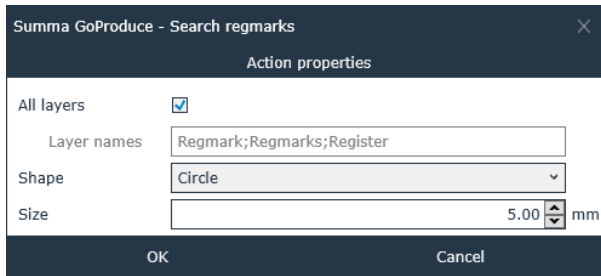

You can scan all layers or enter the name of a specific layer to be scanned. The shape and size of the registration mark also need to be defined. Set all the parameters to the desired value and click **OK**. Then click **Search remarks**. If registration marks are found on the selected layer, they are given this property and are made clearly visible on the screen.



Close objects

This function checks whether all objects are closed. When an object is not closed, this function will close it. This action is applied to all objects. The standard import action will do this automatically (see section 2.4).

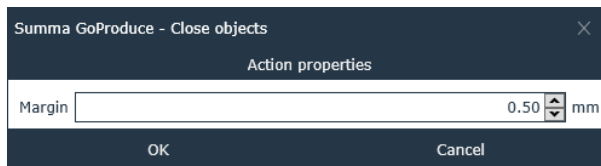

Right-click the **Close objects** icon to define the distance that can be covered to close an object. The maximum allowed value is set at 3 mm.



NOTE: The higher the chosen value, the more cut data and quality can be lost.



Reduce nodes

This function can be used to reduce the number of nodes. This action is applied to all objects. If the distance between three nodes is less than the set value, the middle node is deleted. The two nodes that remain are connected with a line.

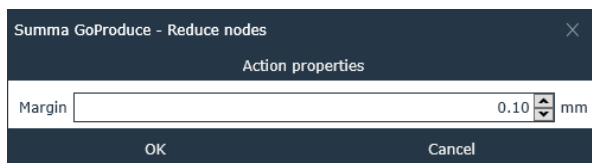

Right-click the **Reduce nodes** icon to define the distance below which the middle nodes must be deleted. The maximum value is 3 mm.



This function breaks curves at intersections and is usually used in combination with other clean-up functions. It isolates common parts of different curves so that those double parts can be deleted. The disadvantage is that after this, some curves will be open, which can negatively affect the sorting process. The maximum allowed value is set at 3 mm.



NOTE: The higher the chosen value, the more cut data and quality can be lost.

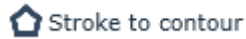

This function converts all strokes to contours. Sometimes jobs are poorly designed, and a contour line was defined using a brush or other less appropriate tool, rather than by a single line. In that case, the program can convert those double lines into a single line. The inner lines will be deleted, and the outer line will be kept. We recommend not to rely on this feature too often but instructing designers to define correct cut lines.

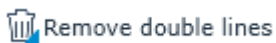

This function automatically selects all lines (open curves) and deletes any double lines. Right-click the icon to set the maximum distance. The maximum allowed value is set at 3 mm.



NOTE: The higher the chosen value, the more cut data and quality can be lost.



This function automatically selects all objects (closed curves) and deletes any double objects. Right-click the icon to set the maximum distance. The maximum allowed value is set at 3 mm.



NOTE: The higher the chosen value, the more cut data and quality can be lost.



This function reveals or hides the orientation of the objects. When you click it, a triangle appears at the starting point of each object, indicating the direction of the curve. Click the triangle to reverse direction, if necessary.



Zoom to fit all

These two shortcut keys allow you to easily zoom in on all objects or the work area.

2.3.2 Selection tab

This tab contains the basic editing functions such as duplicate, resize, ...



Select all

Click this icon to select all objects in the job. Individual objects can be selected by clicking on them. A group of objects can be selected by drawing a selection frame around them; the objects must then be completely inside the frame. Hold down the shift key to add objects to the already selected group. Black selection handles will appear around the selected objects. Use the outer selection handles to resize the objects. Use the middle one to move the objects around.



Node selection



Node selection

Click this icon to reveal or hide the nodes of the selected objects. The selection handles disappear, and the nodes are displayed as squares. The starting point is a square just slightly larger than the others.

Once the nodes are selected, certain properties can be adjusted. Editing the nodes is not possible. Click on a node to make it the new starting point. Clicking on the starting point node reverses the direction of the curve (can be made visible by making the starting point visible with the action in the **Job** tab).



Zoom to fit selection

Click this icon to zoom in on the selected objects.



Duplicate

Click this icon to duplicate the selected objects. The duplicate is placed 5 mm higher and more to the left so that it is clearly visible.



Group Ungroup

Click one of these icons to group or ungroup the selected objects.



This function allows you to resize and reposition the selected objects. The anchor point of an object ("object origin") can be changed by clicking one of the circles. The object can then be moved by changing the X and Y values. This allows you to align objects. The object can be resized by changing the width and height values or the percentage value. You can lock the proportions by clicking on the padlock icon. The origin point remains stationary when the size of the object or group of objects is changed.



Rotates the selected objects. First enter the rotation value, then click the icon. The bottom two icons are used to flip the selected objects horizontally or vertically. When rotating and flipping, the center point always remains stationary.

2.3.3 Material manager tab



GoProduce includes a materials database that contains an extensive range of material types and can be customized to meet specific needs. The material manager offers the advantage of working with methods, which means you only need to select the material you want to process, and then the material manager automatically chooses the correct tool and settings to process the job.







Some RIPs allow selecting the material to be selected already when printing the job. In that case, you do not need to select the material type again in Summa GoProduce. This tab is not used when processing a job, but to predefine settings for different materials.



NOTE: In this tab, the default properties of the materials, methods and camera profiles are chosen. So, if a job is processed and a setting needs to be changed just for this one time, change it in the layer window and not in the **Material Manager** tab.

2.3.3.1 Materials



-  **Default** : Set the selected material as default material. If no material is defined in the cut data file, Summa GoProduce will automatically use the default material.
-  **New** : Create a material.
-  **Import** : Import a material. Several predefined materials are available.
-  **Duplicate** : Duplicate the selected material.
-  **Export** : Export the selected material to use on another computer.
-  **Delete** : Delete the selected material. A material cannot be deleted when it is being used.
-  **Edit** : Edit the selected material.

2.3.3.1.1 Editing a material

Summa GoProduce - Material

Name: Aluminium Composite Board

Category: Aluminium Composite Board

Description:

Camera profiles

Profile type	Camera profile
Regmark	Default
Barcode	Default
Media edge	Default

Finishing presets

Thicknesses	Methods	Tools
0,079 inch	Crease	
0,118 inch	V-Cut 45	
0,157 inch	Thru-cut	
0,236 inch		

OK Cancel

- **Name** and **Category**: A material type is primarily defined by its name and is part of a category.
- **Description**: Add a description that clarifies the material type or add additional information that may be relevant to processing the material.
- **Camera profiles**: A series of default camera profiles are installed when the program is installed. Each material type has three camera type profiles linked to it:
 - *Regmark* is used to recognize registration marks.
 - *Barcode* is used to recognize the barcode.
 - *Media edge* is used to recognize object contours and media edges.
- **Thicknesses**: The different material thicknesses are listed here (some materials have one fixed thickness).



: Add a thickness.



: Make the selected thickness the default thickness (important when there is no material data in the cut file).



: Duplicate the selected thickness.



: Delete the selected thickness.

- **Methods** are chosen in the design program and are linked to a certain tool appropriate for this material.



: Create a method.



: Duplicate the selected method.



: Delete the selected method.

- **Tools:** Click the cross-hatched area of a method to see which tool is linked to it.



: Choose a tool to link to the selected method:

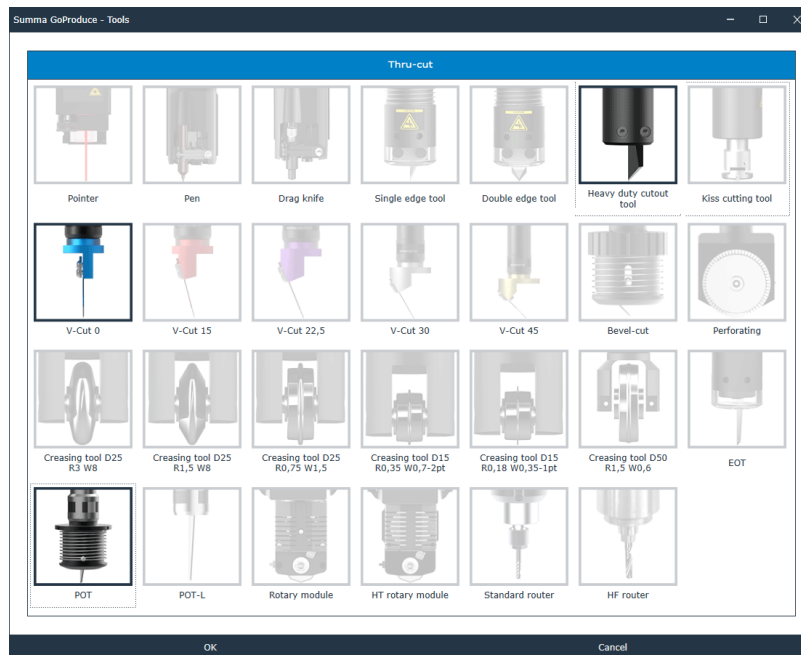

The tools currently linked to this method are highlighted. To add a tool for the selected method, click a non-highlighted tool. To remove a tool for this method, click the highlighted tool again.



: Set the parameters for the selected tool. Select the tool by clicking the cross-hatched area in front of the tool name. You can configure different parameter sets for each tool:

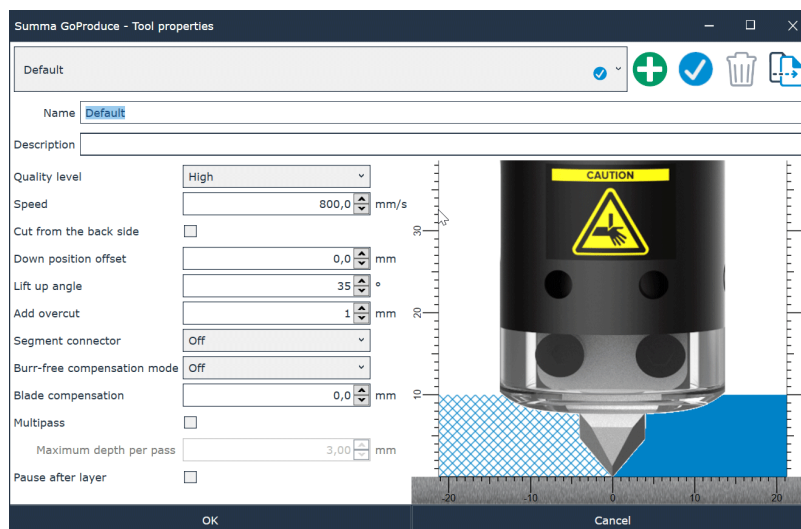

: Create a set of parameters.



: Set this set of parameters as default.



: Delete this set of parameters.



: Duplicate this set of parameters.

2.3.3.1.1.1 Tool parameters

KNIFE TOOLS

- **Quality level:** This is an overall quality parameter, which is default set to *High*. Setting it to *Standard* increases throughput.
- **Speed:** This is the speed at which the knife cuts. Reduce this speed for thicker materials.
- **Cut from the backside:** The tool will be used after the material is flipped (you will be prompted to do so during job processing).



NOTE: When cutting from the backside, it is important that the back of the material is similar to the front of the material structure-wise and color-wise. If it isn't, the *Media Edge* camera profile might have trouble detecting the material edges due to loss of contrast with the conveyor.

- **Down position offset:** The cutting depth can be adjusted with this parameter. This parameter can only take positive values. The maximum cutting depth is calibrated with Axis Control. This parameter can be used if the tool needs to cut less deep than the calibrated depth. The right part of the window visualizes the value of this offset. To the left of the blade, the value is visualized by the blue line. To the right of the blade, the total thickness of the material is visualized. In the example below, the material is 2 mm thick and the offset for depth of cut is set to 1 mm.

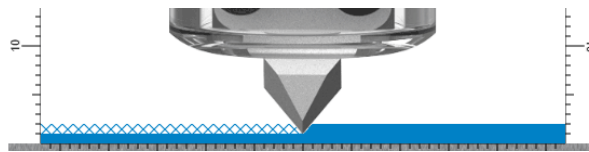

- **Lift up angle:** This is the maximum angle the cutter will cut without having to lift the knife. If the angle between two consecutive vectors is greater than the set value, the cutter lifts the knife, rotates it, sets it down again and then continues cutting. If this value is increased, the job can be cut faster, but the quality will be lower.

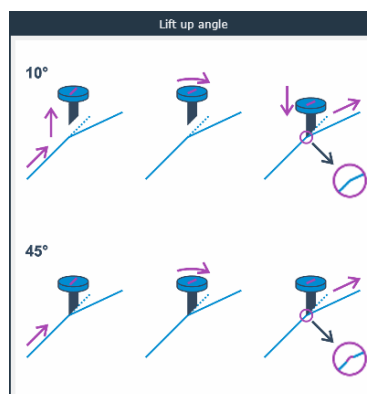

- **Add overcut:** Used to facilitate weeding. Each time before the knife goes up or down, the cutter cuts a little further. This parameter determines how far the knife cuts further. This overcut is the overcut of the centre of the knife point.

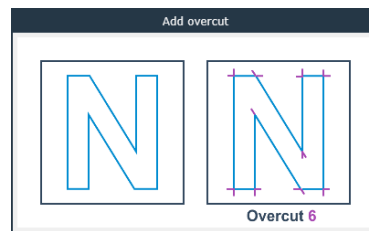

- **Overcut elimination:** Cut-out knives are often used to cut thick materials. This means that a relatively large natural overcut is formed at the top of the material. If the cut-out knife has only one cutting edge (“single edge”), this can be compensated for by cutting the vector in half and ensuring that the machine cuts away from the starting and ending points of each vector. There are four options for this parameter:
 - Off:* The overcut is not compensated for.
 - Keep inner and outer shapes:* The overcut is compensated in each angle where the knife is lifted (and where the angle is greater than the lift-up angle).
 - Keep inner shapes:* Compensation is done only in the inner angles of closed paths.
 - Keep outer shapes:* Compensation is done only in the outer angles of closed paths.

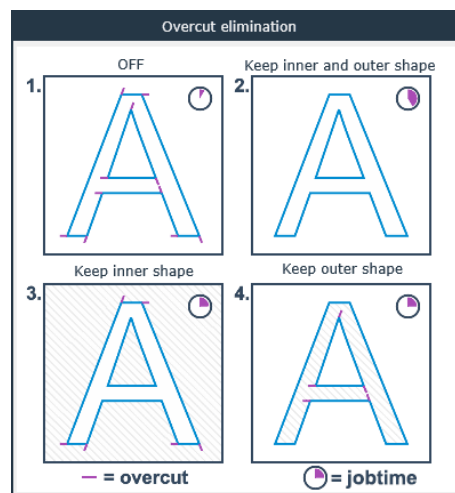

- **Overcut elimination distance:** This is the distance between where compensation is done and the end of the original vector. This value depends on the thickness of the material. Use half of the thickness of the material as value as a quick reference.

- **Segment connector:** With long cut-only jobs, the segments may not align 100%. This parameter solves this by cutting small extra lines (by default 3 mm long) and ensuring that closed curves are closed when cut into segments. This way, large, closed curves are easy to weed.

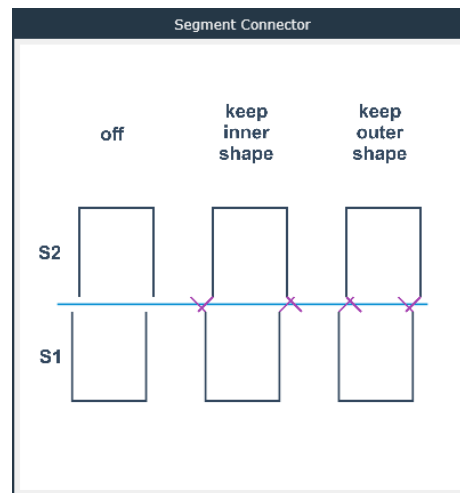

- **Blade compensation:** To obtain a smooth curve, the blade must be adjusted in the direction of the cutting line. When cutting thick materials, the blade direction will only be correct at the bottom of the material. At the top of the material, the blade will not be adjusted in the direction of the cutting line. To compensate, this parameter is used. This parameter anticipates the orientation of the blade by setting a distance so that the upper and lower cuts are both closest to the ideal cutting line. However, this parameter can never fully compensate, due to the physical limitations of the blade and the cutting process.
- **Multipass:** Either the material is too thick to be cut in one pass or the tool cannot cut the material in one pass. This parameter allows the same shape to be cut over multiple passes.
- **Max depth per pass:** This parameter determines the maximum depth per pass.
- **Pause after layer:** A pause can be made after using this tool.

CREASING WHEELS

- **Quality level:** This is an overall quality parameter, which is default set to *High*. Setting it to *Standard* increases throughput.
- **Speed:** This is the speed at which the creasing wheel creases.
- **Cut from the backside:** The tool will be used after the material is flipped (you will be prompted to do so during job processing).



NOTE: When cutting from the backside, it is important that the back of the material is similar to the front of the material structure-wise and color-wise. If it isn't, the *Media Edge* camera profile might have trouble detecting the material edges due to loss of contrast with the conveyor.

- **Down position offset:** The creasing depth can be adjusted with this parameter. This parameter can only take positive values. The maximum creasing depth is calibrated with Axis Control. This parameter can be used if the tool needs to crease less deep than the calibrated depth.
- **Flute direction:** If the material is corrugated, the creasing depth will be oriented too much in one direction (flute direction). In this case, set the flute direction correctly and set an offset for this direction. Possible settings are none, X and Y.

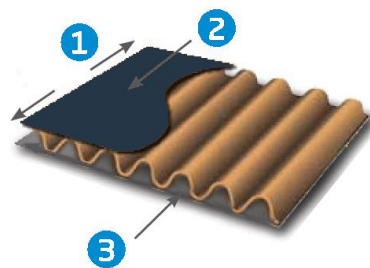

1. Flute direction
2. Top liner (outside)
3. Bottom liner (inside)

- **Pause after layer:** A pause can be made after using this tool.

PERFORATING KNIVES

- **Quality level:** This is an overall quality parameter, which is default set to *High*. Setting it to *Standard* increases throughput.
- **Speed:** This is the speed at which the knife perforates.
- **Cut from the backside:** The tool will be used after the material is flipped (you will be prompted to do so during job processing).



NOTE: When cutting from the backside, it is important that the back of the material is similar to the front of the material structure-wise and color-wise. If it isn't, the *Media Edge* camera profile might have trouble detecting the material edges due to loss of contrast with the conveyor.

- **Down position offset:** The perforating depth can be adjusted with this parameter. This parameter can only take positive values. The maximum perforating depth is calibrated with Axis Control. This parameter can be used if the tool needs to perforate less deep than the calibrated depth.
- **Flute direction:** If the material is corrugated, the creasing depth will be oriented too much in one direction (flute direction). In this case, set the flute direction correctly and set an offset for this direction. Possible settings are none, X and Y.

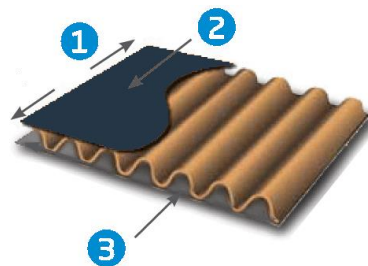

1. Flute direction
2. Top liner (outside)
3. Bottom liner (inside)

- **Overcut elimination:** Cutout knives are often used to cut thick materials. This means that a relatively large natural overcut is formed at the top of the material. If the cut-out knife has only one cutting edge (“single edge”), this can be compensated for by cutting the vector in half and ensuring that the machine cuts away from the starting and ending points of each vector. There are four options for this parameter:
 - Off:* The overcut is not compensated for.
 - Keep inner and outer shapes:* The overcut is compensated in each angle where the knife is lifted (and where the angle is greater than the lift-up angle).
 - Keep inner shapes:* Compensation is done only in the inner angles of closed paths.
 - Keep outer shapes:* Compensation is done only in the outer angles of closed paths.

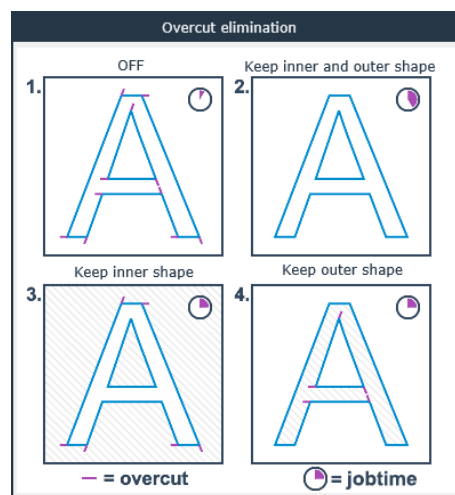

- **Overcut elimination distance:** This is the distance between where compensation is done and the end of the original vector. This value depends on the thickness of the material. Use half of the thickness of the material as value as a quick reference.
- **Pause after layer:** A pause can be made after using this tool.

V-CUT KNIVES

- **Quality level:** This is an overall quality parameter, which is default set to *High*. Setting it to *Standard* increases throughput.
- **Speed:** This is the speed at which the knife cuts.
- **Cut from the backside:** The tool will be used after the material is flipped (you will be prompted to do so during job processing).



NOTE: When cutting from the backside, it is important that the back of the material is similar to the front of the material structure-wise and color-wise. If it isn't, the *Media Edge* camera profile might have trouble detecting the material edges due to loss of contrast with the conveyor.

- **Down position offset:** The cutting depth can be adjusted with this parameter. This parameter can only take positive values. The maximum cutting depth is calibrated with Axis Control. This parameter can be used if the tool needs to cut less deep than the calibrated depth. The right part of the window visualizes the value of this offset. To the left of the blade, the value is visualized by the blue line. To the right of the blade, the total thickness of the material is visualized. In the example below the material is 10 mm thick and the offset for depth of cut is set to 1 mm.

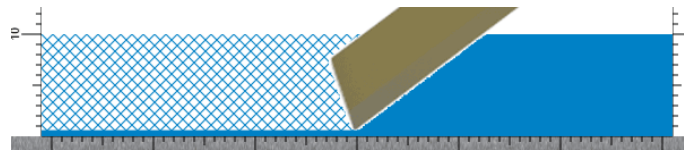

- **Bevel-cut:** This parameter can be set to *Off*, *Keep inner shape* or *Keep outer shape*. A single line in the design cut with a V-cut tool is converted to a double line that creates the V-shape in the material. However, sometimes it may be necessary to cut only one side of the V-shape. This parameter makes this possible and lets you choose which of the two lines.

- **V-Cut Gap:** This parameter can be used to change the base of the V-shape cut by the knife. In the figure below, the down position offset is configured to allow a cut of only 20% into the liner. The denser the core material, the smaller the value for the gap needs to be (1). As a result, the outer corner will appear smoother and sharper. If the liner material is stiffer, a larger gap is required (2). This will result in a duller and larger outer corner.

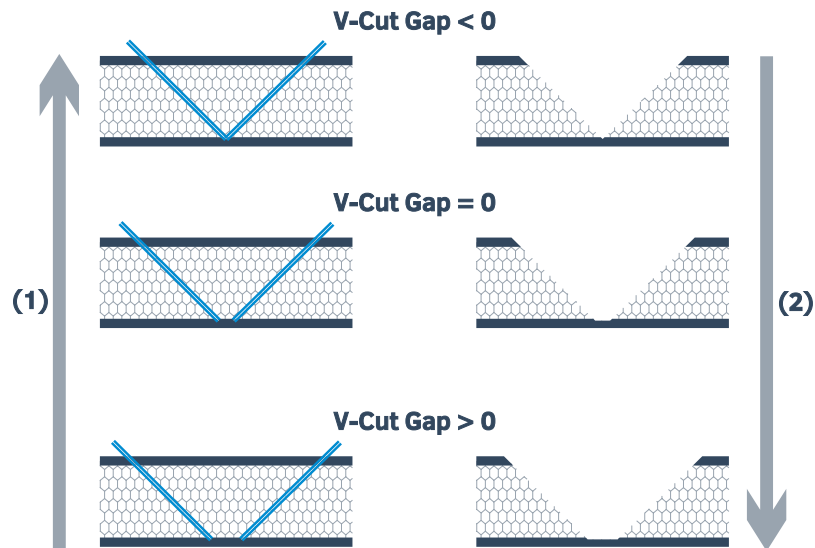

- **Pause after layer:** A pause can be made after using this tool.

BEVEL-CUT KNIVES

- **Quality level:** This is an overall quality parameter, which is default set to *High*. Setting it to *Standard* increases throughput.
- **Speed:** This is the speed at which the knife cuts.
- **Cut from the backside:** The tool will be used after the material is flipped (you will be prompted to do so during job processing).



NOTE: When cutting from the backside, it is important that the back of the material is similar to the front of the material structure-wise and color-wise. If it isn't, the *Media Edge* camera profile might have trouble detecting the material edges due to loss of contrast with the conveyor.

- **Down position offset:** The cutting depth can be adjusted with this parameter. This parameter can only take positive values. The maximum cutting depth is calibrated with Axis Control. This parameter can be used if the tool needs to cut less deep than the calibrated depth. The right part of the window visualizes the value of this offset. To the left of the blade, the value is visualized by the blue line. To the right of the blade, the total thickness of the material is visualized. In the example below, the material is 5 mm thick and the offset for depth of cut is set to 0.5 mm.



- **Bevel-cut:** This parameter can be set to *Off*, *Keep inner shape* or *Keep outer shape*. A single line in the design cut with a V-cut tool is converted to a double line that creates the V-shape in the material. However, sometimes it may be necessary to cut only one side of the V-shape. This parameter makes this possible and lets you choose which of the two lines.

- **V-Cut Gap:** This parameter can be used to change the base of the V-shape cut by the knife. In the figure below, the down position offset is configured to allow a cut of only 20% into the liner. The denser the core material, the smaller the value for the gap needs to be (1). As a result, the outer corner will appear smoother and sharper. If the liner material is stiffer, a larger gap is required (2). This will result in a duller and larger outer corner.

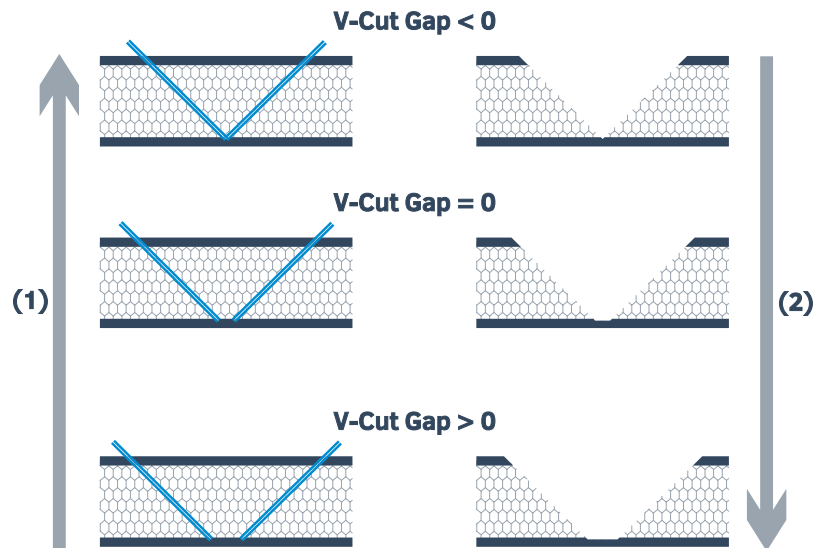

- **Pause after layer:** A pause can be made after using this tool.

PEN TOOL

- **Quality level:** This is an overall quality parameter, which is default set to *High*. Setting it to *Standard* increases throughput.
- **Speed:** This is the speed at which the pen draws.
- **Cut from the backside:** The tool will be used after the material is flipped (you will be prompted to do so during job processing).



NOTE: When cutting from the backside, it is important that the back of the material is similar to the front of the material structure-wise and color-wise. If it isn't, the *Media Edge* camera profile might have trouble detecting the material edges due to loss of contrast with the conveyor.

- **Pause after layer:** A pause can be made after using this tool.

POINTER

- **Quality level:** This is an overall quality parameter, which is default set to *High*. Setting it to *Standard* increases throughput.
- **Speed:** This is the speed at which the pointer moves.
- **Cut from the backside:** The tool will be used after the material is flipped (you will be prompted to do so during job processing).



NOTE: When cutting from the backside, it is important that the back of the material is similar to the front of the material structure-wise and color-wise. If it isn't, the *Media Edge* camera profile might have trouble detecting the material edges due to loss of contrast with the conveyor.

ROTARY KNIVES

- **Quality level:** This is an overall quality parameter, which is default set to *High*. Setting it to *Standard* increases throughput.
- **Speed:** This is the speed at which the knife cuts. Reduce this speed when processing thicker materials.
- **Cut from the backside:** The tool will be used after the material is flipped (you will be prompted to do so during job processing).



NOTE: When cutting from the backside, it is important that the back of the material is similar to the front of the material structure-wise and color-wise. If it isn't, the *Media Edge* camera profile might have trouble detecting the material edges due to loss of contrast with the conveyor.

- **Rotational speed:** Defines the rotational speed of the rotary knife.
- **Lift up angle:** This is the maximum angle the cutter will cut without having to lift the knife. If the angle between two consecutive vectors is greater than the set value, the cutter lifts the knife, rotates it, sets it down again and then continues cutting. If this value is increased, the job can be cut faster, but the quality will be lower.

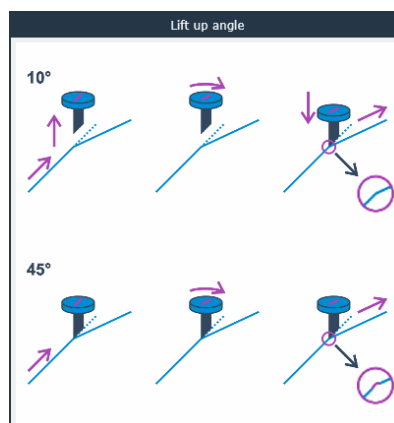

- **Overcut elimination:** A rotary blade creates a very large natural overcut. This can be compensated for by stopping shortly before the end of a vector. There are four options for this parameter:
 - Off:* The overcut is not compensated for.
 - Keep inner and outer shapes:* The overcut is compensated in each angle where the knife is lifted (and where the angle is greater than the lift-up angle).
 - Keep inner shapes:* Compensation is done only in the inner angles of closed paths.
 - Keep outer shapes:* Compensation is done only in the outer angles of closed paths.

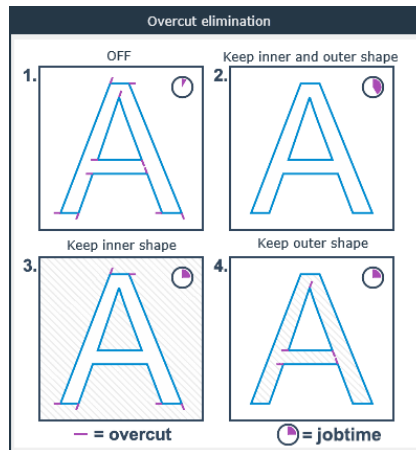

- **Overcut elimination distance:** This is the distance the knife stops before the end of the vector.
- **Segment connector:** With long cut-only jobs, the segments may not align 100%. This parameter solves this by cutting small extra lines (by default 3 mm long) and ensuring that closed curves are closed when cut into segments. This way, large, closed curves are easy to weed.

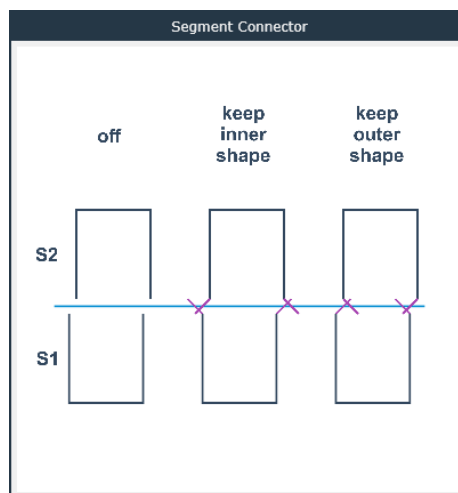

- **Pause after layer:** A pause can be made after using this tool.

ROUTER

- **Quality level:** This is an overall quality parameter, which is default set to *High*. Setting it to *Standard* increases throughput.
- **Speed:** This is the speed at which the routing bit routs. This setting is material dependent.
- **Cut from the backside:** The tool will be used after the material is flipped (you will be prompted to do so during job processing).



NOTE: When cutting from the backside, it is important that the back of the material is similar to the front of the material structure-wise and color-wise. If it isn't, the *Media Edge* camera profile might have trouble detecting the material edges due to loss of contrast with the conveyor.

- **Rotational speed:** Defines the speed of the miller motor. This setting is material-dependent, in combination with the routing speed and bit diameter.



NOTE: This parameter is not visible when the standard router is the selected tool.

- **Bit:** Selection of the used routing bit.
- **Down position offset:** This parameter can be used to set the milling depth. This parameter can only take positive values. The maximum milling depth is calibrated with Axis Control. This parameter can be used if the routing paths do not need to be routed all the way through.
- **Routing path:** This parameter defines what is going to be routed. There are five options for this parameter:
 - As designed:* Routing on the design line.
 - Keep inner shape:* Routing on the outside of the design line.
 - Keep outer shape:* Routing on the inside of the design line.
 - Hatch fill*
 - Island fill*

However, if there are objects within other objects, the routing path moves from side to side for the object located within another object. So, when Summa GoProduce fills object 1 and there is a closed object 2 in this fill, object 2 is not filled. This is repeated when there are more objects in it.

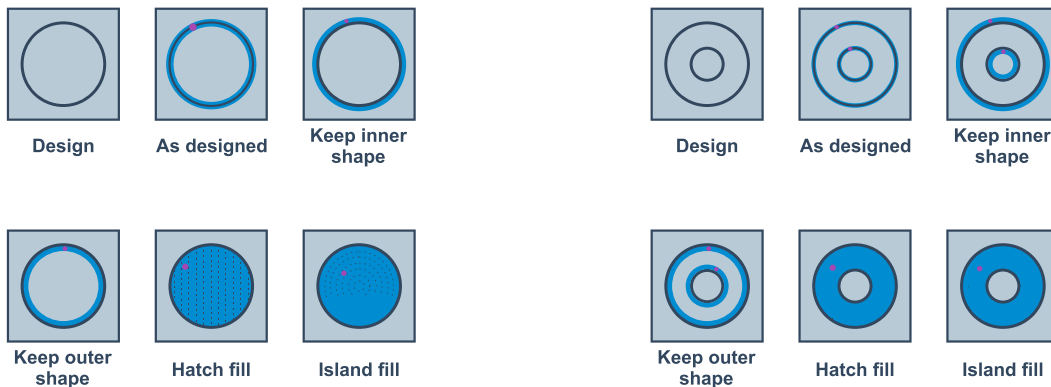

- **Mode:** The routing direction is a material-dependent parameter that significantly affects routing quality. It also affects the longevity of the routing bit. Always try to follow the material or routing bit manufacturer's recommendations. When this info is not available, try both settings (*Climb Milling* and *Conventional Milling*) and check the quality.

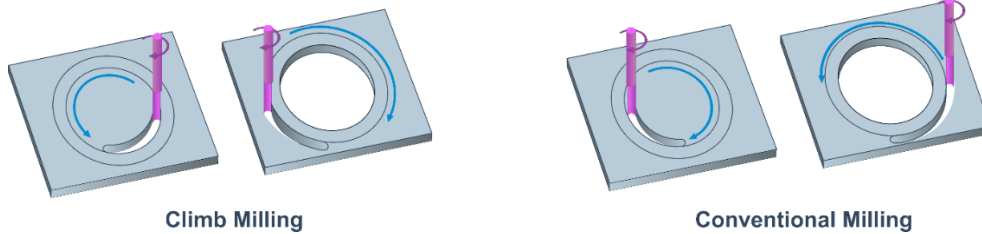

- **Auto inlay:** This option automatically creates a rounded corner, so that routed curves will fit into one another.
- **Roundness:** Defines the diameter of the rounded corner.
- **Tolerance:** Allows a small overall offset to be applied so that the curves fit together loosely.

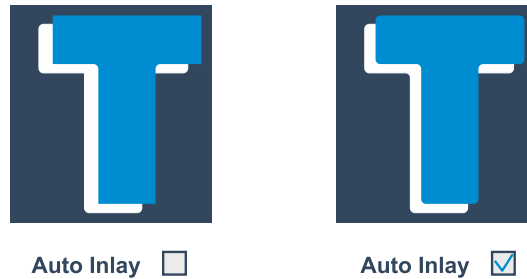

- **Multipass:** This option must be used if the routing cannot be done in one pass. Possible reasons: the material is too thick, the pieces of material to be routed are too small, or a high-quality finish is needed.
- **Max depth per pass:** This parameter defines the maximum depth per pass. It is recommended that the maximum depth per pass be set to no more than the diameter of the router bit. Do not rout materials thicker than 3 to 4 times the routing diameter.

- **Cleaning pass:** This option is used to achieve a better finish when routing and for routing relatively small objects. The clean-up pass is relatively narrow so that the forces exerted during routing are not too great, thus ensuring that the object is not damaged. Common values range from 0.5 to 1 mm. These values depend on the material to be routed, the routing bit diameter, and the routing depth.



NOTE: This parameter is not visible when the standard router is the selected tool.

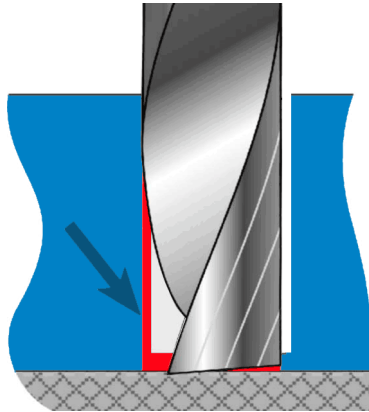

- **Depth:** Defines the depth of the cleaning pass.
- **Offset:** Defines the offset of the other passes to the cleaning pass. Only the clean-up pass will eventually be routed to the size intended as a result.
- **Speed:** Use this parameter if the cleaning pass needs to be routed at a different speed than the previous passes.
- **Polishing pass:** This option is only available when the HF router is used. This allows the routing parameters to be set as needed for a particular polishing bit. The polishing bit is used to obtain a clear finish when routing in acrylic material. Five subparameters must be set:
 - a. *Bit:* The type of polishing bit.
 - b. *Offset:* The offset that will be used.
 - c. *Speed:* The speed of the router motor.
 - d. *Rotational speed:* The routing speed.
 - e. *Mode:* The routing direction (these properties are analogue to those in normal routing).

NOTE: When also polishing, you will have to change router bits during the job. In this case, the cutting table will pause just before it needs the polishing bit and give a notification to change bits.





Other routing jobs may also require the use of different router bits within the same job. In that case, the job will consist of several layers with the same method (Thru-cut with router bit), but with different bits. The table will then pause between each layer when it needs another router bit, allowing you to change bits. At the end of the job, the table will pause and ask you to reinstall the first bit.

- **Pause after layer:** A pause can be made after using this tool.

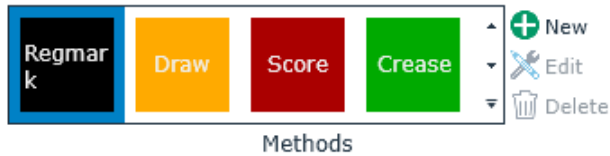
2.3.3.2 Methods



The different methods are used in the design software. A method is material independent and only defines the action/result.





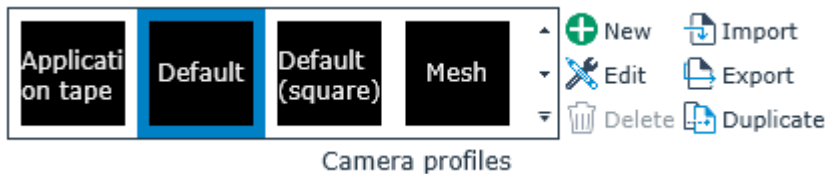

-  **New** : Create a method.
-  **Edit** : Edit the selected method (change its name or colour).
-  **Delete** : Delete the selected method. A method cannot be deleted when it is being used in the material manager.

2.3.3.3 Camera profiles



There are three types of camera profiles: *Regmark* (to detect registration marks), *Barcode* (to detect barcode), and *Media Edge* (to detect object outlines and material edges).

Different registration marks, different registration colours, different material colours... All these parameters influence the parameters the camera needs to recognize the registration marks and material edges. A number of standard camera profiles are installed when installing Summa GoProduce. A single camera profile can usually be used for a wide range of materials.

-  **New** : Create a camera profile (preferably after starting a cutting job, so you can set the parameters based on the job preview shown on the screen).
-  **Import** : Import a camera profile.
-  **Edit** : Edit the selected camera profile (preferably after starting a cutting job, so you can set the parameters based on the job preview shown on the screen).
-  **Export** : Export the selected camera profile to use on another computer.
-  **Delete** : Delete the selected camera profile. A camera profile cannot be deleted when it is being used.
-  **Duplicate** : Duplicate the selected camera profile.



NOTE: We do not recommend changing the parameters of a profile that is installed by default. If parameters of a default installed profile need to be changed (for example, because a strange ambient light source is present), duplicate the profile, rename it, and modify this profile.

2.3.3.3.1 Creating camera profiles

You can create a *Regmark*, *Barcode* or *Media Edge* camera profile. The easiest way to do so is described below.

2.3.3.3.1.1 Regmark

1. Load a job (that contains registration marks) on the conveyor and import the corresponding cutting file in the GoProduce software. If you do not use the default import action set, make sure that it contains the **Search regmarks** action.
2. Click the **Output to Roll** or **Output to Sheet** action set and place the camera above the first registration mark when the software prompts you to.
3. Click **Edit profile settings**.
4. Change the parameter values as required for the software to detect the registration marks (see 2.3.3.3.2 *Parameters* on page 33 for tips). You can follow this on the screen. When a registration mark is detected, it is outlined in green.
5. Click **Save camera profile to material manager**.

2.3.3.3.1.2 Barcode

1. Load a job (that contains registration marks and a barcode) on the conveyor and import the corresponding cutting file in the GoProduce software. If you do not use the default import action set, make sure that it contains the **Search regmarks** action.
2. Click the **Output to Roll** or **Output to Sheet** action set and place the camera above the barcode when the software prompts you to place the camera above the first registration mark.
3. Click **Edit profile settings**.
4. Change the parameter values as required for the software to detect the barcode (see 2.3.3.3.2 *Parameters* on page 33 for tips). You can follow this on the screen.
5. Write down the parameter values.
6. Open the *Barcode* camera profile and change its values to the values you wrote down in the previous step.
7. Click **Save camera profile to material manager**.

2.3.3.3.1.3 Media edge

1. Load a job (that contains registration marks and a barcode) on the conveyor and import the corresponding cutting file in the GoProduce software. If you do not use the default import action set, make sure that it contains the **Search regmarks** action.
2. Click the **Output to Sheet** action set and place the camera above the media edge when the software prompts you to place the camera above the first registration mark.
3. Click **Edit profile settings**.

4. Change the parameter values as required for the software to detect the media edge (see [2.3.3.3.2 Parameters](#) on page 33 for tips). You can follow this on the screen.
5. Write down the parameter values.
6. Open the *Media edge* camera profile and change its values to the values you wrote down in the previous step.
7. Click **Save camera profile to material manager**.







2.3.3.3.2 Parameters

A brief description of all parameters is given below, but not all parameters are available for every type of camera profile. Depending on your choice of camera profile type, certain parameters may or may not need to be set.

- **Mark type:** Can be a circle, a square or a cross. If a registration mark is recognized, it will be outlined in green in the preview.
- **Median filter:** Preserves the edges but smooths out patterns. Tip: Start with a low value and increase if necessary.
- **Truncate filter:** All grey levels above the selected value are reduced to the selected value. Tip: Start with a high value and decrease if necessary.
- **Blur filter:** Blurs the picture slightly to smooth out sharper edges. Tip: Start with a low value and increase if necessary.
- **Edge smoothing filter:** Blurs out the pattern near the edges. Tip: Start with a low value and increase if necessary.
- **Threshold filter:** Sets the level to decide whether an edge is white or black. Tip: Set this filter first. Start with a low value and increase systematically in increments of 10 if necessary.
- **Size margin:** Sets maximum deviation between the size of the printed registration mark and the size in the data file. Tip: Start with a low value and increase if necessary.
- **Minimum roundness:** Sets the maximum deviation between the roundness (difference x size – y size) of the registration mark. Tip: Start with a low value and increase if necessary.

2.3.3.4 Routing bits



-  **New** : Create a new routing bit settings.
-  **Import** : Import a routing bit settings.
-  **Edit** : Edit the selected routing bit settings.
-  **Export** : Export the selected routing bit settings to use on another computer.
-  **Delete** : Delete the selected routing bit settings. A routing bit cannot be deleted when it is used for material that is in the material manager.
-  **Duplicate** : Duplicate the selected routing bit settings.

2.3.4 Devices tab



Click the **Edit** button to set which tools are available.

Edit

Tools

2.3.5 General tab

The fifth tab in the ribbon contains some general parameters and settings.



Information

Click on this icon for information about the program. The license manager opens to add more licenses for additional options, if needed.



Q&A



Tutorials



Tooltips

Click on this icon to connect to the Internet for frequently asked questions and their answers or click on the YouTube logo for a link to small instructional videos. Click the Tooltip icon to switch the tooltips on or off.

Help



Backup Restore Reset Create pdf Create RIP xml

Material manager

Click **Backup** to create a backup of the material manager. Click **Restore** to import a previously created backup. Click **Reset** to reset the material manager. Click **Create pdf** to generate a readable list of all the different materials in the material manager and the tools settings. The option **Create RIP XML** is used to create an XML that can then be imported into the RIP so that the material can be selected when the job is printed.



Click **Backup** to create a backup of the action sets. Click **Restore** to import an earlier saved backup. Click **Reset** to reset the action sets. The purpose of the actions are discussed in the next section. We recommend that you make a backup of your actions before resetting it to avoid losing important action sets.



The available interface languages are displayed here. Click a flag to change the program's interface language to the corresponding country language. The program must be restarted before this change is applied.

mm

cm You can select your unit of measurement here.

inch

Unit

Software

Hardware

Rendering





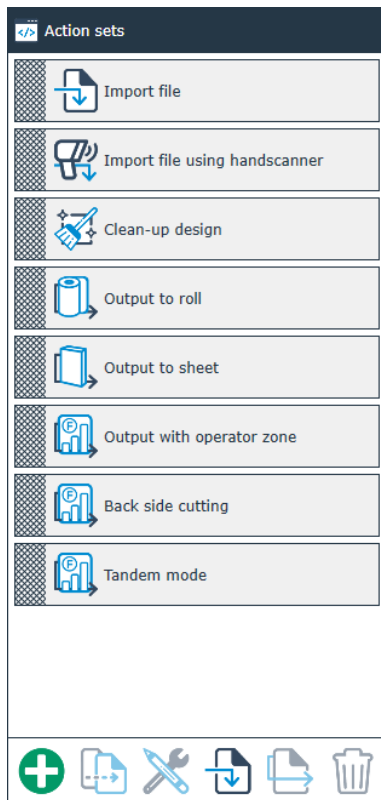

When the camera window in GoProduce shows the video image but freezes when you move the cursor; try changing the camera rendering mode from **Hardware** to **Software**. This issue is possibly related to certain video cards.

2.4 Action sets



Action sets can be workflows or a group of frequently recurring processing functions that determine how the material is to be processed. When Summa GoProduce is installed, a few default action sets are installed as well.

2.4.1 General

-  : Create an action set.
-  : Duplicate the selected action set.
-  : Edit the selected action set.
-  : Import a predefined action set.
-  : Export the selected action set.
-  : Delete the selected action set.



NOTE: Select an action set by clicking the cross-hatched area in front of the action set name.



NOTE: Action properties depend on the chosen workflow (Cut-only or Print&Cut) and on the program configuration (Pro Pack installed or not). This section describes all possible action properties. However, they may not all be available in your configuration.

2.4.2 List of available actions

2.4.2.1 Clean up

Break at intersections: This action breaks curves at intersections. You can also consider objects as intersection points if they are very close to one another. The maximum distance to still be considered intersection points can be set.

Close objects: This action checks whether all objects are closed. If an object is not closed, this action will close it.

Reduce nodes: This action reduces the number of nodes. The distance below which the middle nodes are to be deleted can then be set. This action is applied to all objects.

Remove double lines: This action removes double lines. The action automatically selects all lines (open curves) and deletes any doubles. The maximum distance between the lines can then be set before the software decides whether or not to delete the lines.

Remove double objects: This action removes double objects. This action automatically selects all objects (closed curves) and deletes any doubles. The maximum distance between the objects can then be set before the software decides whether or not to delete the objects.

Stroke to contour: This action converts strokes to contour lines. Sometimes jobs are poorly designed, and a contour line was defined using a brush or other less appropriate tool, rather than by a single line. In that case, the program can convert those double lines into a single line. The inner lines will be deleted, and the outer line will be kept.

2.4.2.2 Device

Set working zone:

- **Working zone:** To set the area of the table that will be used: *Full* (complete area), *Rear zone* (second half of the table so that the first half can be used to remove the already cut parts) or *Tandem* (see p. 46).
- **Origin reset:** This resets the origin to the rightmost point at the bottom (the origin that was set when the machine was switched on).
- **Segmentation margin:** *On* or *Off*. GoProduce calculates its segments in advance. This means that in the case of jobs with registration marks, the segments may actually be scaled larger than originally calculated. GoProduce can take a margin to compensate for this so that the segments still fit on the cutting table.

2.4.2.3 General

Go to: This action can be used to jump to a defined action in the action set. It is usually used to create a loop to automate jobs.

- **Action ID:** Specifies which action the sequence has to be restarted from.

Import job: This action imports a file. There are several parameters.

General

- **Import mode**
 - **Manual:** The operator manually searches and selects the required file.
 - **Barcode:** When this option is selected, more parameters appear:
 - **Barcode reader:** Default set to *Handheld scanner*. When the Pro Pack is activated, *Camera* is available.
 - **Origin:** Determines where the camera starts scanning the barcode. Default set to *Center*. When set to *Center*, *Left* or *Right*, the camera moves to the centre, left or right of the loaded material and scans the material from bottom to top to search for the lower barcode line. When the camera detects this line, it moves to the right side of the line to read the barcode and start the workflow. If set to *Manual*, the camera must be manually placed under the barcode.
 - **Import directory:** This is the folder that contains the cutting data. This is usually a folder on a server where the cutting data is sent from the RIP or design software (click the three dots to browse to the appropriate folder).
 - **Import order:** By creation date or alphabetical.



NOTE: When using barcode, the file name must be between 8 and 13 characters long.

- **Hot folder:** Only available with the Pro Pack. The hot folder system is especially useful when the design software is located on another computer on the network, because then the plug-ins cannot be used. Files stored in a folder can now also be automatically opened in GoProduce. Thanks to the flexible action sets, everything that happens next is completely customized to your needs.
- **Close active job:** You can choose to close the current job before opening a new one, or have a new tab opened containing the job.
- **Combine layers with same name:** Files that are imported sometimes contain multiple layers with the same name. If this option is checked, these layers will be merged into one layer.
- **Scaling factor:** This is used when importing cut-only jobs drawn to scale from Illustrator or Indesign. This is sometimes used for jobs longer than 5 metres (200 inches).



NOTE: Do not use the scaling factor if a PDF creator has been used that scales automatically. Normal PDF export (as in Illustrator and InDesign) outputs files of max. 5 metres (200 inches) wide and long. Some other programs have PDF export filters that output larger PDF files. They have a scale factor in the file itself so the scale factor should stay on 100% for such files.

DXF

- **Import unit for DXF:** Auto, millimetres, inches.
- **Separate layers for PDF/DXF:** The methods can be separated by layer name, by spot colour name, or by colour. We recommend using colours for DXF.
- **Exclude layers:** You can exclude layers from import. This is useful if the print data is still located in the DXF file, because opening this file could slow down the program.

PDF

- **Separate layers for PDF/DXF:** The methods can be separated by layer name, by spot colour name, or by colour. We recommend using layers for PDF.
- **Exclude layers:** You can exclude layers from import. This is useful if the print data is still located in the PDF file, because opening this file could slow down the program.
- **Crop to page size:** For importing only the part of the design that is visible in the PDF file.

SVG

- **Exclude layers:** You can exclude layers from import. This is useful if the print data is still located in the SVG file, because opening this file could slow down the program.

ZCC (only supported when Pro Pack is installed)

The **Shape** and **Size** of the registration marks in the ZCC file must be defined correctly in order to import a ZCC file correctly.

i-CUT (only supported when Pro Pack is installed)

The **Shape** and **Size** of the registration marks in the i-CUT file must be defined correctly in order to import a i-CUT file correctly.

Open job: This action can be used to open a previously saved job (SGPJ file).

- **Close active job:** If you do not check this option, the new job is opened next to the job that is currently active.
- **Combine layers with same name:** Files that are imported sometimes contain multiple layers with the same name. If this option is checked, these layers will be merged into one layer.

Output job: This action sends the job to the cutter. A lot of parameters that are considered default values can be set here. However, when processing the job, these parameters reappear on the screen and, if necessary, can be changed to be applied only this one time. This depends on the parameter setting.

- **Waste Cut:** This action cuts the material over the entire width of the bed for easier weeding of the cut objects. When this option is checked, the number of segments per waste cuts needs to be defined.
- **Segmentation:** If the job exceeds the material size loaded on the flatbed finishing system, Summa GoProduce divides the job into segments. Before the program starts sending the data to the flatbed, a preview can be shown. There are three options for defining segmentation.
 - **Default:** This is typically used when the job is cut on a roll and it does not matter where the different segments are defined. The segments have the maximum size and the last one is the smallest.
 - **Equal length:** This option divides the entire job into equal parts. This can be useful when jobs need to be processed on different panels of the same size.

- **Minimize cut through:** This option tries to place the segment lines so that the objects can be cut without segmenting them. This means adjusting the segments so that all closed curves shorter than the cutting table are cut in one segment.
- **Park position:** This parameter allows you to determine where the tool moves when a job has been processed. The tool can be lifted or moved to the middle or end of the flatbed.
- **Sorting mode:** There are three basic sorting methods to determine the order in which objects are cut: Sort by main direction lengthwise (vertically), by main direction widthwise (horizontally), or by nearest objects. The aim of sorting is to reduce cutting time by moving as little as possible. There are two additional sorting parameters:
 - **Optimize start points:** If checked, the software is allowed to change the starting point of each object to achieve the most efficient cutting path (remember that faster cutting does not necessarily lead to better results).
 - **Inside objects first:** If checked, the software checks for smaller closed curves (objects) inside closed curves (objects). If so, these smaller objects are cut first, to ensure their cutting accuracy.
- **Number of jobs:** This defines how many times the job needs to be repeated.
- **Copies per job:** Sets the number of copies to be processed with this parameter. If sheets are used, this parameter applies to the number of copies per sheet. If the job is on a single sheet or roll, this parameter only determines the number of copies to be processed. There are a few additional options for this parameter if set to more than 1:
 - **Autofill:** If checked, Summa GoProduce checks how many copies can be cut side by side in width. This value then represents the number of copies in width. This option is not usually used in print and cut jobs.
 - **Number of copies - Width:** If the option **Autofill** is not checked, the required number of copies in width direction can be set here.
 - **Space between copies - Width:** Determines the distance between copies in width (imagine a frame around each copy, including registration marks - the distance between those frames is the space between the copies).
 - **Space between copies - Length:** Determines the distance between copies in length (imagine a frame around each copy, including registration marks - the distance between those frames is the space between the copies).



NOTE: If the distance between copies is not known for a Print&Cut job, enter 0. When processing the job, set the camera above the first registration mark of the second copy. The program will then automatically use this distance for the third, fourth, etc. copy.

- **Weed box:** This parameter allows you to place a weed box around a cut-only job. When this option is checked, an additional option is available to determine the distance between the weed box and the job.
- **Send design relative to origin:** If not all objects are selected to be cut, the origin of the job is automatically set to the origin of the selection if this box is not checked. If this box is checked, the origin remains as defined in the job.

- **On end of job:** Determines the action after processing the job:
 - **Replace sheet:** If this option is chosen, you will receive a notification to replace the sheet.
 - **Sheet consistency:** *Low* (different print and/or sheet, different position), *Medium* ((roughly) the same print and/or sheet, different position), or *High* ((roughly) the same print and/or sheet, (roughly) the same position).
 - **Feed job length:** The job length will be fed. If this option is selected, the following parameters appear:
 - **Pause when feeding:** The choice to pause or not, and when.
 - **Margin:** If necessary, a fixed length can be added if you choose to feed after the job. This can be used with cut-only jobs to add a margin between two consecutive jobs.
 - **Cut off:** The choice of whether to cut jobs off a roll.
 - **Feed fixed length:** A fixed length will be fed. If this option is selected, the following parameters appear:
 - **Pause when feeding:** The choice to pause or not, and when.
 - **Feed length:** To set the length that will be fed.
- **Compensation mode:**
 - **Best fit:** The print is followed as accurate as possible but when it is scaled or distorted, only the rectilinear deformations can be compensated for. The vertices remain the same.

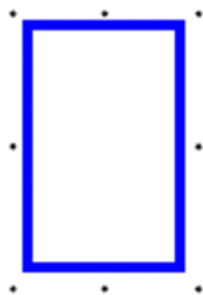

Theoretical shape

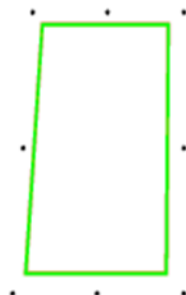

*Example of a distorted outcome with its **printed** and **cut** lines (overlap entirely)*

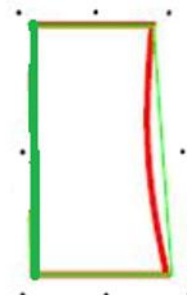

*Example of a distorted outcome with its **printed** and **cut** lines*

- **Best fit (smart compensation):** Whereas with the regular “best fit” compensation mode only rectilinear deformations can be compensated, this limitation does not apply with the smart compensation variant. In the case of curved distortion, the software calculates intermediate points to cut several lines after each other to achieve the curve.

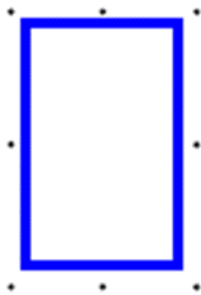

Theoretical shape

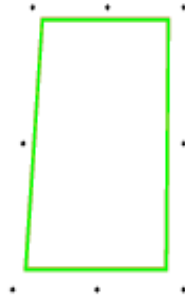

*Example of a distorted outcome with its **printed** and **cut** lines (overlap entirely)*



*Example of a distorted outcome with its **printed** and **cut** lines (overlap entirely)*

- **Fixed size:** Cutting is done according to the shape and size that what was defined in the cut file, considering any scaling or distortion of the print. For example, in the case of a rectangle that was printed scaled or distorted, the software will calculate where that exact rectangle is best cut out.

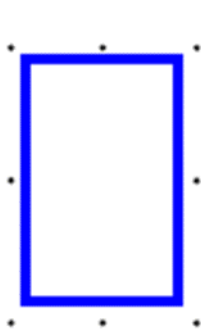

Theoretical shape

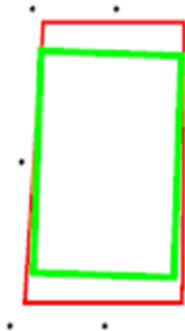

*Example of a distorted outcome with its **printed** and **cut** lines*



*Example of a distorted outcome with its **printed** and **cut** lines*

- **Fixed size (smart compensation):** For single-segment jobs, the smart compensation variant has no added value over the regular fixed size. In that case, the results will be the same. In the case of jobs that do consist of multiple segments, the software will calculate an additional rotation for each segment so that the theoretical shape can still be approximated, within the printed shape.

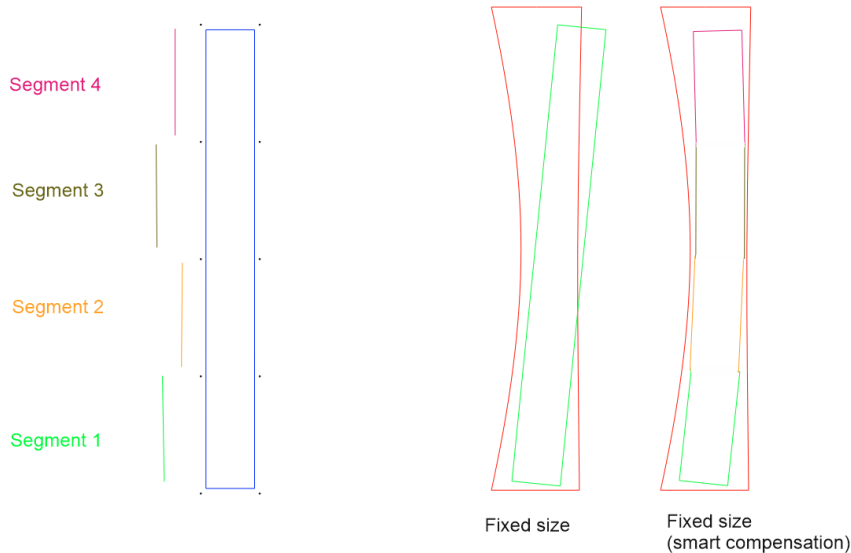

- **Skip mark when mark is not recognized:** Some registration marks might not be printed correctly. If checked, marks that cannot be read by the program are ignored. If unchecked, the program will pause so you can intervene. You can then either skip the registration mark or manually position the camera above it.
- **Plot to file:** This outputs the cutting job to a file instead of to the cutter. We do not recommend checking this option.
- **Direct mode:** If checked, when the output is started, the program does not display the output parameters as described above; the job is started immediately with the settings configured in the action set. This option is essential for the barcode workflow on a roll.

Save job: This action allows you to save the current job as a GoProduce file (SGPJ file type).

Undo: This action undoes the previous one.

2.4.2.4 Job

Fit working area to device: This action fits the working area on the screen to the loaded material (the cutter must be connected, and the material must be loaded).

Mirror horizontally: This action flips the entire job on a horizontal axis through the centre of the job.

Mirror vertically: This action flips the entire job on a vertical axis through the centre of the job.

Rotate 90°: This action rotates all objects and the work area 90° counterclockwise.

Set default material: This action sets the default material. Click the drop-down button in the Action Properties column to get a list of all materials and select the required material.

Set job origin: This action starts a job at a certain offset from the origin. Change the X and Y values as necessary.

2.4.2.5 Layer

Add Thru-cut marks: With this action an extra layer called *Thru-cut Remark* is created. On that layer, small squares are placed exactly on the registration markers. These can then be cut when the registration marks need to be read from the back of the material.

Remove layer: This action deletes a layer. Click the drop-down button in the Action Properties column to get a list of all methods and select the method (layer) to be removed.

Search remarks: This action searches the registration marks. You can scan **All Layers** for this purpose, or only specific layers by entering **Layer names** (layer names are case sensitive). The **Shape** and the **Size** of the registration marks to be searched need to be defined. If registration marks with these characteristics are found on the selected layer, they are given the "Remark" property. They are then moved to the Remark layer and are made clearly visible on the screen.



NOTE: When working with ZCC or i-CUT files, do not forget to set the parameters **Shape** and **Size** correctly in the action properties of the actions **Search remarks** and **Import Job**.

Select layer: This action allows you to select a certain layer (**Method**). Click the drop-down button to get a list of the methods and select one.

Set layer method: Choose the method for the selected layer.

Set layer properties: Layers have two properties. They can be (un)locked and made (in)visible. Set **Target** to determine which layer the properties should apply to.

2.4.3 Predefined action sets

When Summa GoProduce is installed, the following predefined action sets are installed along with it:

- Import file
- Import file using handheld scanner
- Clean-up design
- Output to roll
- Output to sheet
- Output with operator zone
- Tandem mode (see 2.4.3.1 *Tandem mode* on page 46 for more information)



NOTE: When you import a PDF file (action set **Import file**), you will be given the option to choose which pages of the document should be imported.

Other action sets can be imported from `..\Documents\Summa GoProduce\Action sets`:

- Backside cutting (Legacy action set) (see 2.4.3.2 *Backside cutting (Legacy action set)* on page 48 for more information)
- Barcode workflow (is supported only by Pro Pack, see 3.3 *Barcode workflow* on page 54 for more information)
- Twin (X) Mode (is supported only by Pro Pack, see 3.4 *Twin workflow* on page 55 for more information)

If you are using predefined action sets, it is important to know what they do. Right-click in the cross-hatched area in front of the action set name so that the structure of the action set appears. Then, by clicking in the cross-hatched area in front of the action, the specific action properties appear.

2.4.3.1 Tandem mode

In Tandem mode, the active work area on the flatbed can be divided into a front and rear processing area, allowing you to load and unload material on one side of the table while cutting material on the other side of the table. This avoids periods of inactivity during material processing, significantly improving the overall workflow.



To facilitate loading jobs on the table, we recommend marking the loading position of the material. It will not be necessary to do this every time the tandem mode is used; only when the lines have faded is it necessary to redraw them:

1. In Axis Control, go to the **Media** menu > **Origin** > **Pointer**.
2. Use the arrow buttons to move the carriage as far as possible to the front right, or set both origin values to 0 and click **Update**. Mark this point on the conveyor.
3. Use the arrow buttons to move the carriage 150 to 200 mm to the left, or change the Y-value to a value between 150 and 200 and click **Update**. Mark this point.
4. Use the arrow buttons to move the carriage as much as possible to the right and then 150 to 200 mm to the rear, or set the origin values both to 0, click Update, change the X-value to a value between 150 and 200 mm and click **Update** again. Mark this point.
5. Move the carriage out of the way and draw a line from the origin point (step 2) to the other two points (steps 3 and 4).
6. Use the arrow buttons to move the carriage back to the origin point or set both origin values to 0 mm and click **Update**. Then click **Apply**.

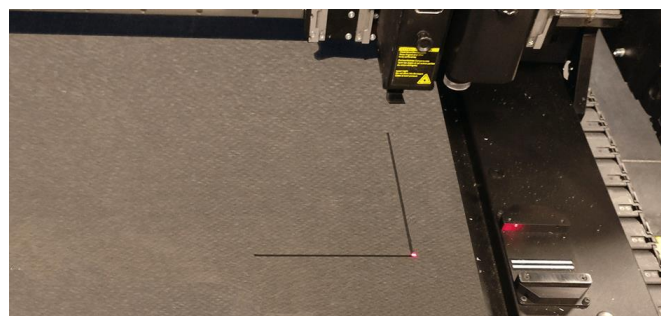

7. Click **Size** > **Pointer**.

8. Use the arrow buttons to move the carriage as much as possible to the rear left, or change the length value to 3200 and the width value to 3260, then click **Update**. Mark this point on the conveyor. This is the full size marker point.
9. Use the arrow buttons to move the carriage 150 to 200 mm to the right, or change the width value to 3060 and click **Update**. Mark this point.
10. Use the arrow buttons to move the carriage as much as possible to the left and then 150 to 200 mm to the front, or set the length value to 3000, the width value to 3260 and click **Update**. Mark this point.
11. Move the carriage out of the way and draw a line from the full size marker point (step 8) to the other two points (steps 9 and 10).
12. Use the arrow buttons to move the carriage back to the full size marker point, or change the length value to 3200 and the width value to 3260, then click **Apply**. This marks the opposite origin point for the tandem mode.

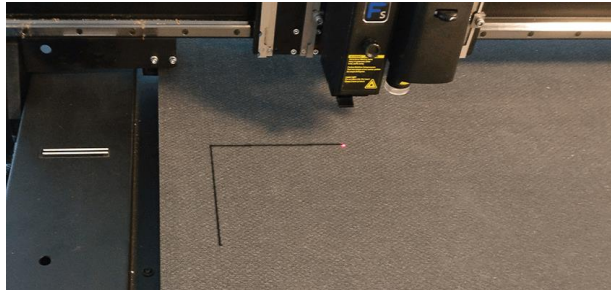

Now that all the required markings have been drawn on the conveyor belt, tandem mode can be started.

If, however, the position of the conveyor and the origin points need to be corrected after the conveyor has moved because of another job, perform the following steps:

1. Check if the front origin point is visible on the right side. If this is the case, click **Media** in Axis Control > **Origin** > **Pointer**.
2. Place the pointer above the corner of the origin mark and click **Feed**.
3. If the origin mark is not accessible, click **Feed** and feed the conveyor 3000 mm.
4. Perform another check.

To start the tandem workflow, perform the following steps:

1. In Summa GoProduce, click the **Tandem mode** action set.
2. If necessary, change the parameters (the default setting for the number of jobs/sheets is 100). Once the parameters are set, click **Run**.
3. While the job is being processed, you can place a new sheet on the other side of the flatbed.
4. Once this is done, click **Release rear/front zone** (depending on which side the flatbed is cutting). If the zone is not released, the table will pause after processing the job and prompt you to replace the sheet. The machine will wait until this is done. Click **Resume**, otherwise the table will continue processing the next copy.

2.4.3.2 Backside cutting (Legacy action set)

Use this action set when the material needs to be cut from the backside. The software adds an additional layer, called *Thru-cut Remark*, and places squares where the registration marks are in the *Remark* layer. A tool is automatically assigned to it (if necessary, adjust/check this method/tool setting in the material manager). The marks are read, and the squares are cut out. You will then be asked to turn the sheet over. The squares just cut out are recognized as square registration marks and the job is cut. The figure below shows the orientation of the material.

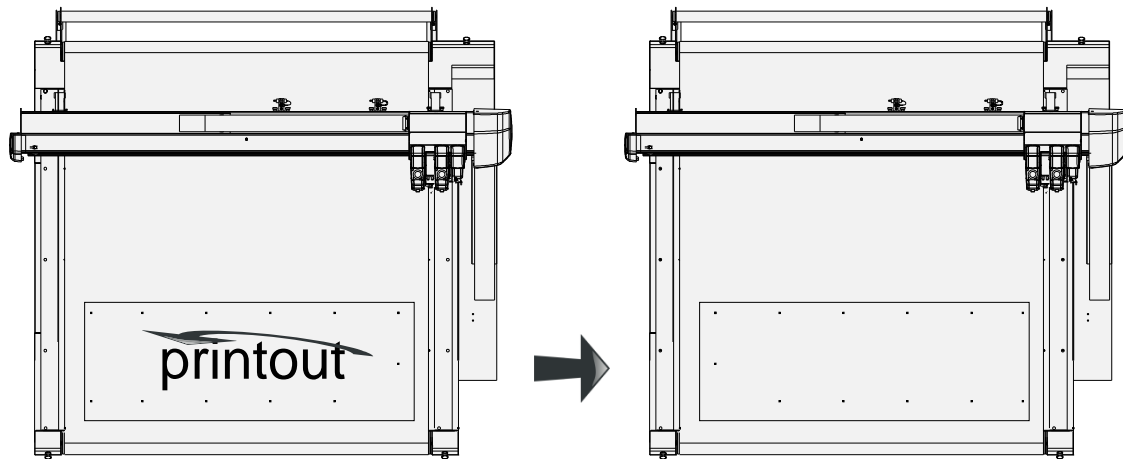



NOTE: The registration marks in the image above represent cut-out marks and show how to flip the material.

2.4.4 Creating action sets

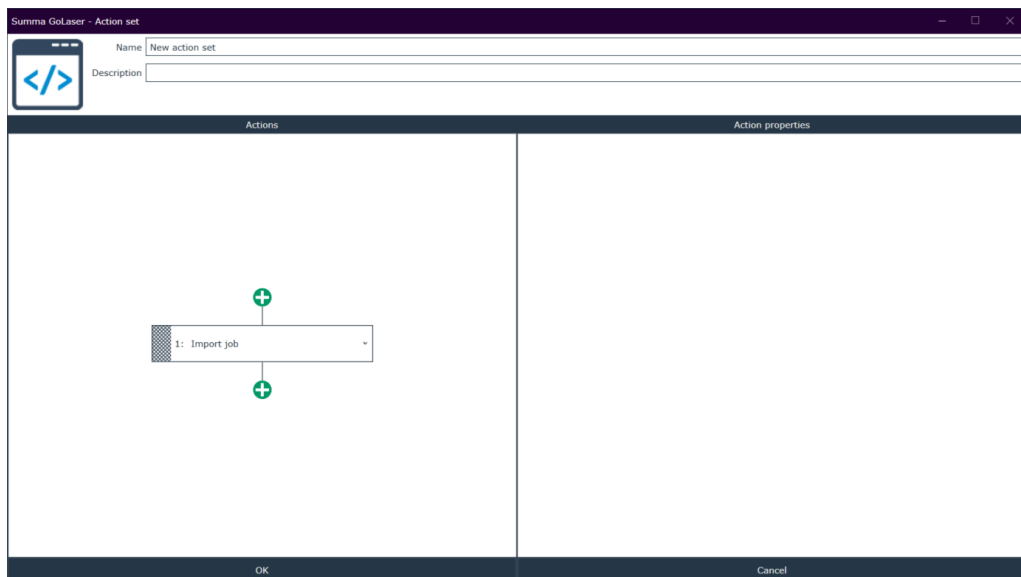
1. Click  to create an action set. The following window appears.



2. Name the action set, describing clearly what it is used for. You can also add a description as additional information and choose a different logo by clicking the default logo .
3. Click the drop-down button to the right of the action name to choose an action. This list contains all the actions of the Job and Selection tabs, and some additional actions.
4. Click in the cross-hatched area in front of the action number. If special settings need to be changed for this action, they are now listed in the right column.
5. Add as many actions as needed to create a new action set. If you need to change the order () of the actions or delete () an action, click in the cross-hatched area before the action number so that these buttons become available.

2.5 Layer window

2.5.1 General

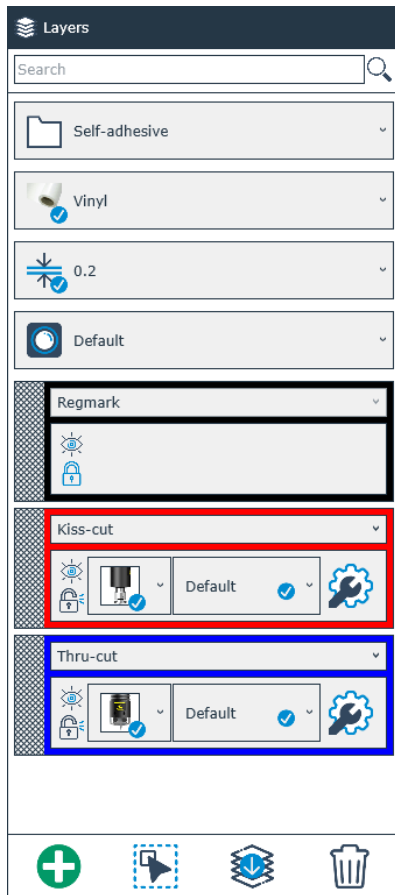

The Layers window shows the material, method, and tool settings. If the RIP has a driver for Summa GoProduce and the settings in the RIP are correct, all the information in this window is automatically chosen as soon as the file with the cut data is imported. If the automatically chosen settings are not correct, you can set things manually. In that case, after importing the cut data file, the **Layers** window looks like this.



NOTE: When making changes in the **Layers** window, always work from top to bottom as changing a setting may influence all the settings below.



NOTE: If the **Import file** action set is set to separate layers by layer name, all objects in unknown layers names (methods) are put in the top layer of the list.



: Create a layer.



: Show only the selected layer.



: Hide only the selected layer.



: Select all objects on the selected layer.



: Move all current objects to the selected layer.



: Delete the selected layer.



: Lock or unlock this layer.



: Open a list of tool parameters to change the parameters. From the moment a parameter is changed, the **Save to material manager** button becomes available to change the setting permanently in the material manager.

2.5.2 Set materials

If the material is not specified in the cut data file, the default material is used. If you need to change the default material, you can do so before opening the cut data file (see page 12) or you can change the material in the **Layers** window when the cut data file is opened.

Option 1: Enter the name of the material in the search box.

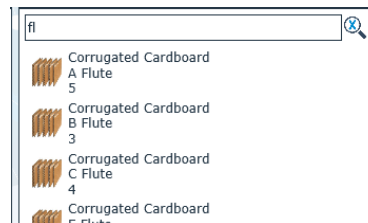

Option 2: First select the relevant material group, then the material itself.

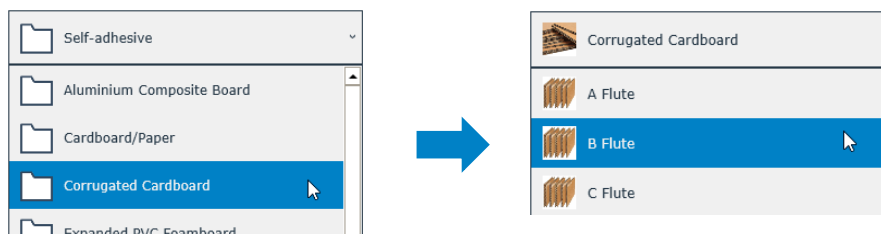

Finally, select the thickness in case the material on the table does not have the default material thickness.

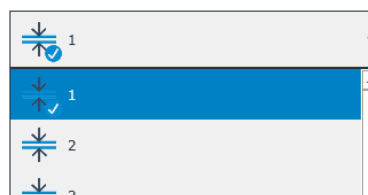

2.5.3 Set camera profiles

If the methods are set correctly in the cut data file, the camera profile should be set correctly automatically. If you want to use another camera profile, you can select it from the drop-down list (the registration marks need to be identified first by clicking **Search remarks** in the **Job** ribbon).

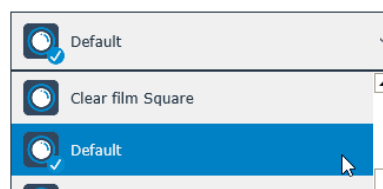

2.5.4 Set methods/tool parameters

If everything is set up correctly, it is not necessary to change the method or tool (settings). However, if a special material is used or the data in the cut file is not set correctly, the methods and associated tools can be set/changed.

The cut data is shown on layers. In simple cut-only jobs requiring only one tool, there may be only one layer. If more than one tool is needed, there will be more layers. For example, in a print and cut job, there is a Regmark layer and a layer per method.

Possible layer properties after importing:

2.5.4.1 Case 1: Material and method set correctly in the cut data file

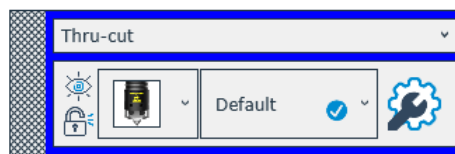

This means that a method has been assigned to the cut lines on that layer and a tool has been assigned to the methods, according to the data in the material manager. The settings for that tool are also copied from the material manager.

Click the drop-down button of the layer name to change the method for the vectors on that layer.

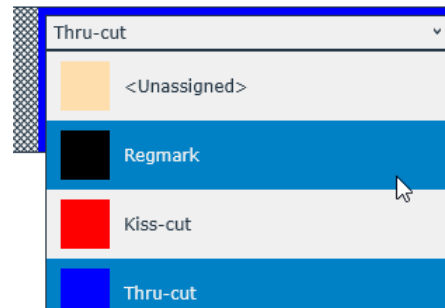

Click the drop-down button next to the tool icon to change the tool if necessary. The program always shows the default tool after having imported the file and the assigned layer/method. If available and required, an alternative tool can be used.

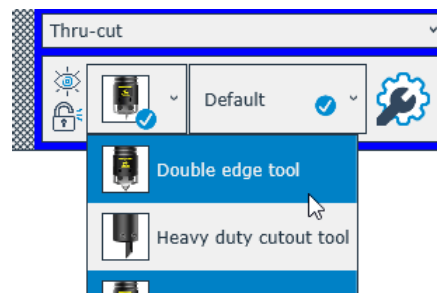

Sometimes a list is available next to the tool type with predefined parameter sets for the chosen tool. The default setting will always be chosen, but alternative parameter sets, if available, can be chosen by clicking the dropdown list.

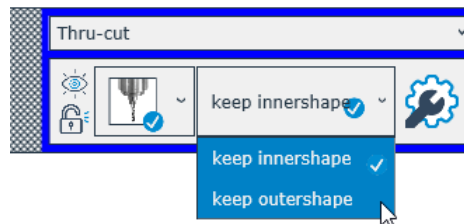

2.5.4.2 Case 2: Material not set correctly / wrong method chosen for material

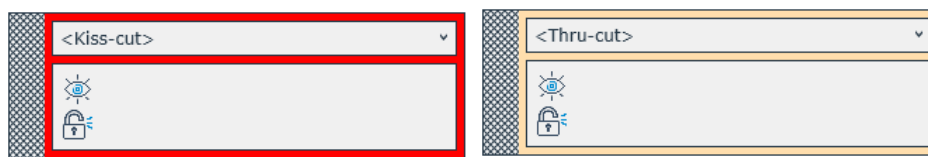

Either the material has not been set correctly or the wrong method for that particular material type has been chosen. To set the material correctly, see section 2.5.2. If the material is set correctly, a tool will be assigned to it automatically. You can also change the method by clicking the drop-down button next to the method name. Once the method and material are set correctly, the parameters can be changed as described in section 2.5.4.1.

2.5.4.3 Case 3: Method is unknown (or not correctly set in the design program)

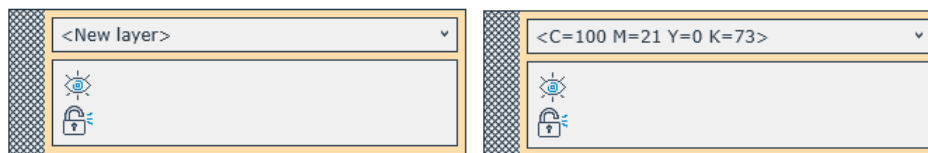

When a new layer is created, when the method is incorrectly assigned, or when no specific color is chosen in the design, the layer information will look like this. In this case, the material settings must be checked first. If the correct material has not yet been set, this must be done first. Then click the drop-down button to choose the correct method.

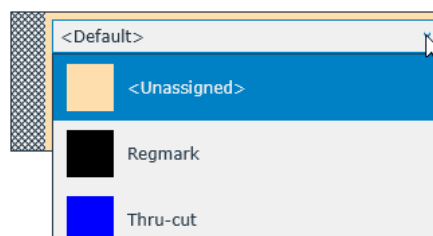

3 PRO PACK

3.1 General

The optional GoProduce Pro Pack offers the following advanced features:

- Ability to import other file types
- Ability to export to PDF
- Barcode Workflow
- Twin Workflow
- Hot folder support

3.2 Ability to import other file types

Thanks to the Pro Pack, the following file types can also be imported:

- PLT files (*.plt, *.PLT)
- HPGL files (*.hpgl, *.hpg, *.hgl, *.HPG, *.HGL)
- DMPL files (*.dmpl, *.dmp, *.DMPL, *.DMP)
- i-CUT files (*.cut, *.CUT)
- ZCC files (*.zcc, *.ZCC)

3.3 Barcode workflow

3.3.1 About barcode workflow

The camera of the F Series can also read barcodes. Certain RIP's can print a POSTNET type barcode together with the OPOS marks. This barcode can then be used to identify the job and retrieve the required cut data automatically from the computer.



NOTE: If there is no data on the material in the data file, the program uses the settings defined in the default material. In this case, before starting the workflow, check the setting of the default material and change if needed.



NOTE: Be sure to select the import directory and the origin in the **Import Job** action properties before starting the workflow (see 2.4.2.3 General > parameters **Import directory** and **Origin** on page 38 for more information).

You can import the *Barcode workflow* file from `..\Documents\Summa GoProduce\Action sets`. This will add two action sets to the **Action sets** window:

- Barcode workflow on roll
- Barcode workflow on sheet

3.3.1.1 Barcode workflow on roll

This workflow is used for jobs printed on a roll. When the action set is started, the program gives control to Axis Control. Axis Control reads the barcode and triggers Summa GoProduce to open the file with the required data and send this data to the cutter. After the job is finished, Summa GoProduce returns control to Axis Control so that it can check for another job with a barcode printed on the roll. If this is the case, the entire procedure repeats itself. Check the F Series manual to find out how to calibrate Axis Control to read the barcode correctly.

3.3.1.2 Barcode workflow on sheet

This workflow is very similar to the barcode workflow on roll. The only difference is that instead of searching for a barcode after finishing one job, the program prompts the operator to replace the sheet. If you replace the sheet and place the new one in the same place as the previous one, the barcode will be read, and the job will be processed.

3.4 Twin workflow

3.4.1 About Twin workflow

By combining the best of both worlds, kiss-cutting on a roll cutter and cutting through on the F Series flatbed cutter, a significant performance increase can be achieved. Especially in combination with the barcode functionality.

How does it work?

1. The material rolls are processed on a roll cutter, cutting kiss-cutting lines only. Kiss-cutting is much faster on a roll cutter than on any flatbed cutter.
2. The material is loaded on the F Series, cutting cut-through lines. This is useful when a complete cut-through line is required and it creates the possibility to reduce the workload on your roll cutters, so that more jobs can be processed.

The Twin workflow is covered in detail in the GoSign manual.

3.5 Hot folder support

The hot folder system is specifically useful when the design software is located on another computer in the network, because in this case the plug-ins cannot be used. Files stored in a folder can automatically be opened in GoProduce. Thanks to the flexible action sets, everything that happens next is completely customized to your needs.



NOTE: In the properties of the import action, the type of import needs to be set to **Hot folder** and the import directory needs to be specified. In the output action the property **Direct mode** needs to be checked.