

F SERIES™

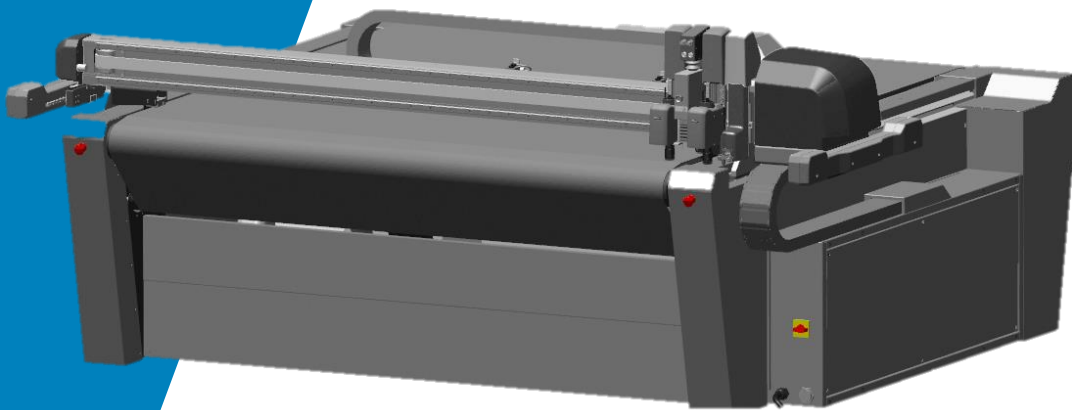

**Options, Consumables
and Accessories**



F SERIES™

Notice

Summa reserves the right to modify the information, contained in this document, at any time without prior notice. Unauthorized copying, modification, distribution or display is prohibited. All rights reserved.

Copyright © Summa NV

F SERIES™

1 TABLE OF CONTENTS

1.1	F1432	6
1.1.1	Electrical Wiring Options	7
1.1.2	Miscellaneous Options.....	7
1.1.3	Software	8
1.1.4	Modules	9
1.1.5	Mats And Belts.....	10
1.2	F1612	11
1.2.1	Electrical Wiring Options	11
1.2.2	Miscellaneous Options.....	11
1.2.3	Automated Depth Control	11
1.2.4	Media Handling Options	12
1.2.5	Software	13
1.2.6	Modules	14
1.2.7	Mats And Belts.....	15
1.3	F1832	21
1.3.1	Electrical Wiring Options	21
1.3.2	Miscellaneous Options.....	21
1.3.3	Automated Depth Control	21
1.3.4	Media Handling Options	21
1.3.5	Software	23
1.3.6	Modules	24
1.3.7	Mats And Belts.....	25
1.4	F3220	27
1.4.1	Electrical Wiring Options	27
1.4.2	Miscellaneous Options.....	27
1.4.3	Automated Depth Control	27
1.4.4	Media Handling Options	29
1.4.5	Software	29
1.4.6	Modules	30
1.4.7	Mats And Belts.....	31
1.5	F3232.....	32
1.5.1	Electrical Wiring Options	32
1.5.2	Miscellaneous Options.....	32
1.5.3	Automated Depth Control	32
1.5.4	Media Handling Options	32
1.5.5	Software	34
1.5.6	Modules	35
1.5.7	Mats And Belts.....	36
1.6	Consumables & Accessories for Drag Module	37
1.7	Tools For Tangential Module.....	38

1.8	Consumables & Accessories for Tangential Module.....	42
1.9	Consumables & Accessories for Routing Module	46
1.10	Consumables & Accessories for Rotary Module	51
1.11	General Accessories	51

F SERIES™

On the following pages you will find an overview of all the items that can be purchased additionally for your F-series flatbed cutter.

1.1 F1330

1.1.1 Mats And Belts

Part number	Description	Image
500-9163	Conveyor belt kit	
500-9164	Two protective mats 134cm x 170cm x 2.5mm	-
500-9333	Routing mat (1.54m) – 11.4m x 1.53m x 2mm	-
500-9336	Routing mat (1.3m) – 11.4m x 1.3m x 2mm	-

1.2 F1432





1.2.1 Electrical Wiring Options

Part number	Description	Image
500-9237	Factory-installed 3x230V (3-phase) (EU only)	-

1.2.2 Miscellaneous Options

Part number	Description	Image
500-9165	Kit pump connection 12m (single pump version)	-
500-9166	Kit pump connection 25m (single pump version)	-
500-9520	F-performance mode (for units built before 2018) (US only)	-
500-9359	Vacuum unit Delfin DM3EL 110V (US only)	
500-9155	Kit pump connection 12m (US only)	-
500-9156	Kit pump connection 25m (US only)	-
500-9345	Vacuum cleaner 3000w: Hercules (check power requirements) (EU only)	
500-9520	F-performance mode (for units built before 2018) (EU only)	-



1.2.3 Software

Part number	Description	Image
500-9511	Summa GoProduce (upgrade from SummaFlex Pro)	
500-9515	Summa GoProduce Update 2.x to 3.x	
500-9517	Summa GoProduce Update 1.x to 3.x	
500-9513	Summa GoProduce Pro Pack	
500-9423	Summa GoConnect – Licence for board feeders	-

1.2.4 Media Handling Options

Part number	Description	Image
500-9415	Upgrade media clamp bar kit	-

1.2.5 Modules

Part number	Description		Image
500-9300	Drag module (for table calibration, drag knife cutting up to 600g, and pen drawing) including:		
	9TL89-67033	Standard drag knife holder dia. 1.5mm	
	-	Drag knife 36° dia. 1.5, offset 0.45mm ¹	
	-	Fibre tip black pen ²	
500-9310	Tangential module		
500-9497	1400W router system including:		-
	500-9462	1400W milling motor & module Collets 3, 4, 6, 8 mm & 1/4-inch, 4mm bit – up to 10mm deep ³	
	500-9467	Electronics, cables, and hoses	
	500-9471	Gantry	
	500-9336	Routing mat	

¹ Also available in a set of 5: 9TL89-67041.

² Also available in a set of 4: MP06BK.

³ Also available in a set of 3: 500-9852.

Part number	Description		Image
500-9531	HF router system including:		-
	500-9463	Routing module, SycoTec milling motor, collet 6 mm, 4mm bit – up to 12mm deep ⁴	
	500-9466	Electronics, cables, and hoses	
	500-9471	Gantry	
	500-9336	Routing mat	
500-9361	High-torque rotary module including 1 decagonal knife of 28mm ⁵		-

1.2.6 Mats And Belts

Part number	Description	Image
500-9189	Conveyor belt kit	
500-9333	Routing mat (1.54m) – 11.4m x 1.53m x 2mm	-
500-9336	Routing mat (1.3m) – 11.4m x 1.3m x 2mm	-

⁴ Also available in a set of 3: 500-9856.



⁵ Also available in a set of 3: 500-9861.

1.3 F1612

1.3.1 Electrical Wiring Options

Part number	Description	Image
500-9230	Factory-installed 3x230V (3-phase) (EU only)	-
500-9231	Field change kit 3x400+N to 3x230V (3-phase) (EU only)	-

1.3.2 Miscellaneous Options

Part number	Description	Image
500-9345	Vacuum cleaner 3000w: Hercules (check power requirements) (EU only)	
500-9520	F-performance mode (for units built before 2018)	-
500-9359	Vacuum unit Delfin DM3EL 110V (US only)	

1.3.3 Automated Depth Control

Part number	Description	Image
500-9125	Field upgrade: ADC right ⁶	-
500-9126	Field upgrade: ADC left ⁷	-

⁶ For legacy units only. Standard included in new units.





⁷ For legacy units only. Standard included in new units. Requires ADC right.

1.3.4 Media Handling Options



Part number	Description	Image
500-9425	Sheet Feed 75 F16xx bundle	
500-9422	Levelling kit for use with board feeders (extra kit needed for conveyor extension front)	
500-9421	Roll support elevation kit / kit feeder connection (for units built before May 2024)	
500-9140	Conveyor extension front (extends conveyor by 120cm)	
500-9122	Roll-up	
500-9120	Media basket 160cm (64inch) ⁸	-
500-9121	Sturdy folding extension table 180cm x 90cm	-
500-9414	Upgrade kit media clamp bar	-

⁸ When used in combination with 320cm (128inch) cutters, two baskets are required.

1.3.5 Software

Part number	Description	Image
500-9511	Summa GoProduce (upgrade from SummaFlex Pro)	
500-9515	Summa GoProduce Update 2.x to 3.x	
500-9517	Summa GoProduce Update 1.x to 3.x	
500-9513	Summa GoProduce Pro Pack	
500-9423	Summa GoConnect – Licence for board feeders	-

1.3.6 Modules

Part number	Description		Image
500-9300	Drag module (for table calibration, drag knife cutting up to 600 g, and pen drawing) including:		
	9TL89-67033	Standard drag knife holder dia. 1.5mm	
	-	Drag knife 36° dia. 1.5, offset 0.45mm ⁹	
	-	Fibre tip black pen ¹⁰	
500-9310	Tangential module		
500-9496	1400W router system including:		-
	500-9462	1400W milling motor & module Collets 3, 4, 6, 8 mm & 1/4-inch, 4mm bit – up to 10mm deep ¹¹	
	500-9464	Electronics, cables, and hoses	
	500-9470	Gantry	
	500-9333	Routing mat	

⁹ Also available in a set of 5: 9TL89-67041

¹⁰ Also available in a set of 4: MP06BK

¹¹ Also available in a set of 3: 500-9852

Part number	Description		Image
500-9530	HF router system including:		-
	500-9463	Routing module, SycoTec milling motor, collet 6 mm, 4mm bit – up to 12mm deep ¹²	
	500-9465	Electronics, cables, and hoses	
	500-9470	Gantry	
	500-9333	Routing mat	
500-9361	High-torque rotary module including 1 decagonal knife of 28mm ¹³		-

1.3.7 Mats And Belts



Part number	Description	Image
500-9114	Conveyor belt kit	
500-9115	Protective mat 166cm x 170cm x 2.5mm	-
500-9118	Conveyor belt kit for extended F1612	
500-9333	Routing mat (1.54m) – 11.4m x 1.53m x 2mm	-
500-9336	Routing mat (1.3m) – 11.4m x 1.3m x 2mm	-

¹² Also available in a set of 3: 500-9856

¹³ Also available in a set of 3: 500-9861

1.4 F1625

1.4.1 Miscellaneous Options

Part number	Description	Image
500-9345	Vacuum cleaner 3000W: Hercules (check power requirements) (EU only)	
500-9359	Vacuum unit Delfin DM3EL 110V	



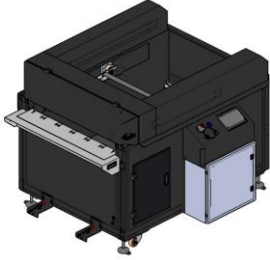

1.4.2 Media Handling Options

Part number	Description	Image	
500-9422	Levelling kit for use with board feeders ¹⁴		
500-9120	Media basket 160cm (64inch) ¹⁵	-	
500-9121	Sturdy folding extension table 70inch x 35inch	-	
500-9414	Upgrade kit media clamp bar	-	
500-9425	Sheet Feed 75 for bundle including:		
	500-3475	Sheet feeder	
	500-9422	Levelling kit	
	500-9423	Summa GoConnect sheet feed license	
	500-9424	Connection kit	

¹⁴ Extra kit required for conveyor extension front

¹⁵ When used in combination with 128inch cutters, two basketes are required.

1.4.3 Software

Part number	Description	Image
500-9511	Summa GoProduce (upgrade from SummaFlex Pro)	
500-9515	Summa GoProduce Update 2.x to 3.x	
500-9517	Summa GoProduce Update 1.x to 3.x	
500-9513	Summa GoProduce Pro Pack	
500-9423	Summa GoConnect – Licence for board feeders	-

1.4.4 Modules

Part number	Description		Image
500-9300	Drag module (for table calibration, drag knife cutting up to 600 g, and pen drawing) including:		
	9TL89-67033	Standard drag knife holder dia. 1.5mm	
	-	Drag knife 36° dia. 1.5, offset 0.45mm ¹⁶	
	-	Fibre tip black pen ¹⁷	
500-9310	Tangential module		
500-9540	1400W router system including:		-
	500-9462	1400W milling motor & module Collets 3, 4, 6, 8 mm & 1/4-inch, 4mm bit – up to 10mm deep ¹⁸	
	500-9477	Electronics, cables, and hoses	
	500-9473	Gantry	
	500-9333	Routing mat	

¹⁶ Also available in a set of 5: 9TL89-67041

¹⁷ Also available in a set of 4: MP06BK

¹⁸ Also available in a set of 3: 500-9852

Part number	Description		Image
500-9534	HF router system including:		-
	500-9463	Routing module, SycoTec milling motor, collet 6 mm, 4mm bit – up to 12mm deep ¹⁹	
	500-9474	Electronics, cables, and hoses	
	500-9473	Gantry	
	500-9333	Routing mat	
500-9361	High-torque rotary module including 1 decagonal knife of 28mm ²⁰		-

1.4.5 Mats And Belts

Part number	Description	Image
500-9333	Routing mat (1.54m) – 11.4m x 1.53m x 2mm	-
500-9336	Routing mat (1.3m) – 11.4m x 1.3m x 2mm	-
500-9134	Conveyor belt kit	

¹⁹ Also available in a set of 3: 500-9856



²⁰ Also available in a set of 3: 500-9861

1.5 F1832

1.5.1 Electrical Wiring Options

Part number	Description	Image
500-9236	Factory-installed 3x230V (3-phase) (EU only)	-

1.5.2 Miscellaneous Options

Part number	Description	Image
500-9155	Kit pump connection 12m	-
500-9156	Kit pump connection 25m	-
500-9345	Vacuum cleaner 3000w: Hercules (check power requirements) (EU only)	
500-9359	Vacuum unit Delfin DM3EL 110V (US only)	
500-9520	F-performance mode (for units built before 2018)	-

1.5.3 Automated Depth Control

Part number	Description	Image
500-9135	Field upgrade: ADC left ²¹	-





1.5.4 Media Handling Options

Part number	Description	Image
500-9412	Heavy duty roll support	-

²¹ For legacy units only. Standard included in new units. Requires ADC right (not included).

500-9413	Upgrade kit media clamp bar	-
----------	-----------------------------	---

1.5.5 Software

Part number	Description	Image
500-9511	Summa GoProduce (upgrade from SummaFlex Pro)	
500-9515	Summa GoProduce Update 2.x to 3.x	
500-9517	Summa GoProduce Update 1.x to 3.x	
500-9513	Summa GoProduce Pro Pack	
500-9423	Summa GoConnect – Licence for board feeders	-

1.5.6 Modules

Part number	Description		Image
500-9300	Drag module (for table calibration, drag knife cutting up to 600 g, and pen drawing) including:		
	9TL89-67033	Standard drag knife holder dia. 1.5mm	
	-	Drag knife 36° dia. 1.5, offset 0.45mm ²²	
	-	Fibre tip black pen ²³	
500-9310	Tangential module		
500-9498	1400W router system including:		-
	500-9462	1400W milling motor & module Collets 3, 4, 6, 8 mm & 1/4-inch, 4mm bit – up to 10mm deep ²⁴	
	500-9467	Electronics, cables, and hoses	
	500-9471	Gantry	
	500-9333	Routing mat	

²² Also available in a set of 5: 9TL89-67041.

²³ Also available in a set of 4: MP06BK.

²⁴ Also available in a set of 3: 500-9852.

Part number	Description		Image
500-9532	HF router system including:		-
	500-9463	Routing module, SycoTec milling motor, collet 6 mm, 4mm bit – up to 12mm deep ²⁵	
	500-9466	Electronics, cables, and hoses	
	500-9471	Gantry	
	500-9333	Routing mat	
500-9361	High-torque rotary module including 1 decagonal knife of 28mm ²⁶		-

1.5.7 Mats And Belts

Part number	Description	Image
500-9355	Conveyor belt kit	
500-9356	Two protective mats 189cm x 170cm x 2.5mm	-
500-9333	Routing mat (1.54m) – 11.4m x 1.53m x 2mm	-
500-9336	Routing mat (1.3m) – 11.4m x 1.3m x 2mm	-

²⁵ Also available in a set of 3: 500-9856.

²⁶ Also available in a set of 3: 500-9861.

1.6 F2630

1.6.1 Mats And Belts

Part number	Description	Image
500-9153	Conveyor belt kit	 A photograph showing the components of a conveyor belt kit. It includes two long, thin wooden rollers, a roll of grey conveyor belt material, a small blue plastic component, a metal bracket, and a red cable.
500-9154	Two protective mats 269cm x 170cm x 2.5mm	-
500-9333	Routing mat (1.54m) – 11.4m x 1.53m x 2mm	-
500-9336	Routing mat (1.3m) – 11.4m x 1.3m x 2mm	-

1.7 F3220

1.7.1 Electrical Wiring Options

Part number	Description	Image
500-9237	Factory-installed 3x230V (3-phase) (EU only)	-

1.7.2 Miscellaneous Options

Part number	Description	Image
500-9155	Kit pump connection 12m	-
500-9156	Kit pump connection 25m	-
500-9165	Kit pump connection 12m (for single pump version)	-
500-9166	Kit pump connection 25 (for single pump version)	-
500-9345	Vacuum cleaner 3000w: Hercules (check power requirements) (EU only)	
500-9359	Vacuum unit Delfin DM3EL 110V (US only)	
500-9520	F-performance mode (for units built before 2018)	-

1.7.3 Automated Depth Control





Part number	Description	Image
500-9136	Field upgrade: ADC left ²⁷	-

²⁷ For legacy units only. Standard included in new units. Requires ADC right (not included).

1.7.4 Media Handling Options

Part number	Description	Image
500-9120	Media basket 1.6m (64inch) ²⁸	-
500-9410	Heavy duty roll support	-
500-9411	Upgrade kit media clamp bar	-

1.7.5 Software

Part number	Description	Image
500-9511	Summa GoProduce (upgrade from SummaFlex Pro)	
500-9515	Summa GoProduce Update 2.x to 3.x	
500-9517	Summa GoProduce Update 1.x to 3.x	
500-9513	Summa GoProduce Pro Pack	
500-9423	Summa GoConnect – Licence for board feeders	-

²⁸ When used in combination with 3.2 m (128inch) cutters, two baskets are required.

1.7.6 Modules

Part number	Description		Image
500-9300	Drag module (for table calibration, drag knife cutting up to 600g, and pen drawing) including:		
	9TL89-67033	Standard drag knife holder dia. 1.5mm	
	-	Drag knife 36° dia. 1.5, offset 0.45 mm ²⁹	
	-	Fibre tip black pen ³⁰	
500-9310	Tangential module		
500-9499	1400W router system including:		-
	500-9462	1400W milling motor & module Collets 3, 4, 6, 8 mm & 1/4-inch, 4mm bit – up to 10mm deep ³¹	
	500-9467	Electronics, cables, and hoses	
	500-9472	Gantry	
	500-9333	Routing mat (2x)	

²⁹ Also available in a set of 5: 9TL89-67041.

³⁰ Also available in a set of 4: MP06BK.

³¹ Also available in a set of 3: 500-9852.

Part number	Description	Image	
500-9533	HF router system including:	-	
	500-9463		Routing module, SycoTec milling motor, collet 6 mm, 4mm bit – up to 12mm deep ³²
	500-9466		Electronics, cables, and hoses
	500-9472		Gantry
	500-9333		Routing mat (2x)
500-9361	High-torque rotary module including 1 decagonal knife of 28mm ³³	-	

1.7.7 Mats And Belts

Part number	Description	Image
500-9182	Conveyor belt kit	
500-9333	Routing mat (1.54 m) – 11.4m x 1.53m x 2mm	-
500-9336	Routing mat (1.3 m) – 11.4m x 1.3m x 2mm	-

³² Also available in a set of 3: 500-9856.



³³ Also available in a set of 3: 500-9861.

1.8 F3232

1.8.1 Electrical Wiring Options

Part number	Description	Image
500-9236	Factory-installed 3x230V (3-phase)	-

1.8.2 Miscellaneous Options

Part number	Description	Image
500-9155	Kit pump connection 12m	-
500-9156	Kit pump connection 25m	-
500-9345	Vacuum cleaner 3000w: Hercules (check power requirements)	
500-9359	Vacuum unit Delfin DM3EL 110V (US only)	
500-9520	F-performance mode (for units built before 2018)	-

1.8.3 Automated Depth Control

Part number	Description	Image
500-9135	Field upgrade: ADC left ³⁴	-

1.8.4 Media Handling Options





Part number	Description	Image
-------------	-------------	-------

³⁴ For legacy units only. Standard included in new units. Requires ADC right (not included).



500-9120	Media basket 1.6m (64inch) ³⁵	-
500-9410	Heavy duty roll support	-
500-9411	Upgrade kit media clamp bar	-

³⁵ When used in combination with 3.2 m (128inch) cutters, two baskets are required.

1.8.5 Software

Part number	Description	Image
500-9511	Summa GoProduce (upgrade from SummaFlex Pro)	
500-9515	Summa GoProduce Update 2.x to 3.x	
500-9517	Summa GoProduce Update 1.x to 3.x	
500-9513	Summa GoProduce Pro Pack	
500-9423	Summa GoConnect – Licence for board feeders	-

1.8.6 Modules

Part number	Description		Image
500-9300	Drag module (for table calibration, drag knife cutting up to 600 g, and pen drawing) including:		
	9TL89-67033	Standard drag knife holder dia. 1.5mm	
	-	Drag knife 36° dia. 1.5, offset 0.45mm ³⁶	
	-	Fibre tip black pen ³⁷	
500-9310	Tangential module		
500-9499	1400W router system including:		-
	500-9462	1400W milling motor & module Collets 3, 4, 6, 8 mm & 1/4-inch, 4mm bit – up to 10mm deep ³⁸	
	500-9467	Electronics, cables, and hoses	
	500-9472	Gantry	
	500-9333	Routing mat (2x)	
500-9533	HF router system including:		-
	500-9461	Routing module, SycoTec milling motor, collet 6 mm, 4mm bit – up to 12mm deep ³⁹	
	500-9466	Electronics, cables, and hoses	
	500-9472	Gantry	
	500-9333	Routing mat (2x)	
500-9361	High-torque rotary module including 1 decagonal knife of 28mm ⁴⁰		-

³⁶ Also available in a set of 5: 9TL89-67041

³⁷ Also available in a set of 4: MP06BK

³⁸ Also available in a set of 3: 500-9852

³⁹ Also available in a set of 3: 500-9856

⁴⁰ Also available in a set of 3: 500-9861



1.8.7 Mats And Belts

Part number	Description	Image
500-9181	Conveyor belt kit	
500-9333	Routing mat (1.54 m) – 11.4m x 1.53m x 2mm	-
500-9336	Routing mat (1.3 m) – 11.4m x 1.3m x 2mm	-

1.9 Consumables & Accessories for Drag Module

Part number	Description	Image
391-231	Drag knife 60', dia. 1.5mm, offset 0.50mm	
391-358	Drag knife 55', dia. 2.0mm, offset 0.90mm (5x)	
391-363	Drag knife holder (copper) dia. 2.0mm for sandblast knives #391-358	
395-430	Roller ball black (5x)	
395-434	Universal pen holders (2 types) for drag head	
9TL89-67033	Standard drag knife holder, dia. 1.5mm	
9TL89-67041	Standard drag knife 36', dia. 1.5mm, offset 0.45mm (5x)	
MP06BK	Fibre tip black pen (4x)	

1.10 Tools For Tangential Module



Part number	Description		Image
500-9311	Kiss-cutting tool including:		
	-	Springs up to 120 g (1x), 650 g (1x), 1800 g (1x)	
	395-348	Standard nose piece	
	-	Standard tangential knife ⁴¹	
500-9312	Single-edge cutout tool with gliding disk including:		
	500-9801	Single edge cutout blade 65°	
500-9313	Double-edge cutout tool with gliding disk including:		
	500-9802	Double-edge cutout blade 50°	
	500-9803	Double-edge cutout blade 60°	
500-9314	Heavy-duty cutout tool including:		
	500-9807	Heavy-duty cutout blade 45°/90°	
500-9315	Perforating tool including:		-
	500-9891	Knife	
	500-9892	Knife	
	500-9893	Knife	
500-9316	Bevel-cut tool including:		-
	500-9829	Bevel-cut knife	

⁴¹ Also available in a set of 5: 390-534

Part number	Description		Image
500-9320	Electronic oscillating tool, stroke 1mm including:		
	500-9811	Knife OT L35 65°-85° ⁴²	
500-9321	Corrugated tool including:		-
	500-9820	Coated knife	
	-	2 compression wheels	
500-9324	Creasing tool D50 R1.5 H0.6		-
500-9325	Creasing tool D25 R3 W8 H7		
500-9326	Creasing tool D25 R1.5 W8 H5.5		
500-9327	Creasing tool D25 R0.75 W1.5 H1.5		

⁴² Requires regular service maintenance. A set of two is recommended.

Part number	Description		Image
500-9328	Creasing tool D15 R0.35 W0.7 H1 - 2PT		
500-9329	Creasing tool D15 H1.5 – 1PT		
500-9340	V-cut tool 0° including:		
	500-9825	Set of 5 V-cut blades 0.9mm	
500-9826	Hard metal V-cut blade		
500-9341	V-cut tool 15° including:		
	500-9825	Set of 5 V-cut blades 0.9mm	
500-9826	Hard metal V-cut blade		
500-9342	V-cut tool 22.5° including:		
	500-9825	Set of 5 V-cut blades 0.9mm	
500-9826	Hard metal V-cut blade		

Part number	Description		Image
500-9343	V-cut tool 30° including:		
	500-9825	Set of 5 V-cut blades 0.9mm	
	500-9826	Hard metal V-cut blade	
500-9344	V-cut tool 45° including		
	500-9825	Set of 5 V-cut blades 0.9mm	
	500-9826	Hard metal V-cut blade	
500-9350	Pneumatic oscillating tool (POT) including:		
	Knife POT flat point L20 T0.63 ⁴³		
500-9358	Pneumatic oscillating tool long (POT-L) including:		-
	Knife POT-L L50 T1 ^{43,44,45,46}		





⁴³ Requires dry & high-volume compressed air.

⁴⁴ Also available in a set of 3: 500-9835.

⁴⁵ Maximum material thickness: 42mm / 1.67".

⁴⁶ Can only be used with 50mm long knives.

1.11 Consumables & Accessories for Tangential Module

Part number	Description	Image
Kiss Cutting Tool – 500-9311		
390-534	Standard tangential knife 36' (5x)	
390-550	Tangential knife 60' sandblast	
390-551	Tangential double-tip knife 36'	
390-560	Tangential knife 45°, wedge 40/25°	
395-348	Nose piece, standard	
500-3318	Depth adjust kiss-cut knife holder	
390-553	Tangential knife installation tool	

Electronic Oscillating Tool – 500-9320		
500-9800	Knife OT L25 65° ^{47,48}	
500-9810	Knife OT L25 / 65°-80° ^{49,50,51}	
500-9811	Knife OT L25 / 65°-85° ^{56,57,58}	
500-9812	Knife OT L28 / 65°-85° ^{58,52,53}	
500-9813	Knife OT L25 / 0°-65° ^{57,58,54}	
500-9814	Knife OT L38 / 45°-86° ^{58,55,56}	
500-9815	Knife OT L33 / 45°-85° ^{58,57,58}	
Single Edge Cut Out Tool – 500-9312		
500-9801	Single-edge cutout knife 65° ^{59,60}	-
Double Edge Cut Out Tool – 500-9313		
500-9802	Double-edge cutout knife 50° ^{61,62}	
500-9803	Double-edge cutout knife 60° ^{52,63}	-
500-9804	Double-edge cutout knife 50° burr-free (2x) ^{51,52}	-

⁴⁷ Up to 5mm thick material.

⁴⁸ Tool holder: 500-9320.

⁴⁹ Up to 11mm thick material.

⁵⁰ Up to 5mm thick material with gliding disk.

⁵¹ Tool holder: 500-9320.

⁵² Up to 14mm thick material.

⁵³ Up to 8mm thick material with gliding disk.

⁵⁴ Up to 6mm thick material.

⁵⁵ Up to 24mm thick material.

⁵⁶ Up to 18mm thick material with gliding disk.

⁵⁷ Up to 19mm thick material.

⁵⁸ Up to 13mm thick material with gliding disk.

⁵⁹ Up to 6mm thick material.

⁶⁰ Tool holder: 500-9312.

⁶¹ Up to 3mm thick material.

⁶² Tool holder: 500-9313.

⁶³ Up to 5mm thick material.

Heavy Duty Cut Out Tool – 500-9314		
500-9807	Heavy-duty cutout knife 45°/90° ^{64,65}	-
V Cut Tools – 500-9340 – 500-9341 – 500-9342 – 500-9343 – 500-9344		
500-9825	V-cut blade 0.9mm (5x)	-
500-9826	V-cut blade hard metal	-
Bevel Cut Tool – 500-9316		
500-9827	Burr-free bevel-cut knife for tool holder #500-9316	-
500-9829	Symmetrical bevel-cut knife for tool holder #500-9316	-
Pneumatic Oscillating Tool – 500-9350		
500-9830	POT knife flat point L20 T0.63 (3x) (tool: POT #500-9350)	-
500-9831	POT knife flat point L27 T0.63 (3x) (tool: POT #500-9350)	
500-9832	POT knife flat point L20 T1.5 (3x) (tool: POT #500-9350)	
500-9833	POT knife serrated flat point L27 T1 (3x) (tool: POT #500-9350)	
500-9834	POT knife L20 T1 (3x) (tool: POT #500-9350) ⁶⁶	
Pneumatic Oscillating Tool – Long – 500-9358		
500-9835	POT-L knife L50 T1.0 (3x) (tool: POT-L #500-9358)	-

⁶⁴ Up to 15mm thick material.

⁶⁵ Tool holder: 500-9314.

⁶⁶ Recommended: Use only with extra protection mat!

Perforating Tool – 500-9315		
500-9890	Perforating knife 1x1mm D1.1mm (12TPI)	-
500-9891	Perforating knife 1.7x1.7mm D1.1mm (8TPI)	-
500-9892	Perforating knife 3x3mm D4mm (4TPI)	-
500-9893	Perforating knife 5x5mm D4mm (3PTI)	-
Corrugated Tool – 500-9321		
500-9820	50° symmetrical coated knife up to 5 mm	-
500-9821	65° symmetrical coated knife up to 8 mm	-
500-9822	50° burr-free coated knife up to 5 mm	-

1.12 Consumables & Accessories for Routing Module

Part number	Description	Image
500-0241	3mm collet for 1050 FME	
500-0242	4mm collet for 1050 FME	
500-0243	6mm collet for 1050 FME	
500-0244	8mm collet for 1050 FME	
500-0256S	Replacement vacuum hose F1612 (US only)	-
500-0355	3mm collet for 1400 FME	
500-0356	4mm collet for 1400 FME	
500-0357	6mm collet for 1400 FME	
500-0358	6-35mm collet for 1400 FME-P	-
500-0359	8mm collet for 1400 FME-P	
500-1265	Vacuum hose F1612 (US only)	
500-3362	Hose D51 vacuum cleaner (US only)	-

Part number	Description	Image
500-9334	Replacement milling motor 1000W (until stocks last) (EU only)	
500-9359	Vacuum unit Delfin DM3EL 110V (US only)	
500-9379	6mm collet for HF router 4041 (#500-9461)	
500-9380	4m collet for HF router 4041 (#500-9461)	-
500-9382	6mm collet for HF router 5045 (#500-9463)	-
500-9850	Bit D3/3 L38/11 1FL UC MP (3x)	-
500-9852	Bit D4/4 L50/12 1FL UC MP (3x)	-
500-9854	Bit D6/3 L50/06 1FL UC MP (3x)	-
500-9856	Bit D6/4 L50/12 1FL UC MP (3x)	-
500-9857	Bit D6/6 L50/12 1FL UC BAL MP (3x)	-
500-9858	Bit D6/6 L58/22 1FL UC BAL MP (3x)	-
500-9863	Bit D6/10 L50/6 V-groove 2FL 90° (2x)	
500-9864	Bit D6/6 L50/22 2FL UC/DC (2x)	
500-9865	Bit D6/6 L50/12 1FL UC BAL CT (3x)	-
500-9866	Bit D6/3 L50/11 1FL DC MP (3x)	-
500-9867	Bit D6/3 L50/6 1FL UC CT MP (3x)	-

500-9868	Bit D6/4 L50/12 1FL UC CT MP (3x)	-
500-9869	Bit D6/2 L50/6 1FL UC CT MP (3x)	-
500-9870	Bit D6/4 L50/6 1FL UC CT MP (3x)	-

Part number	Description	Image
500-9872	Bit D3/3 L38/6 1FL UC MP (3x)	-
500-9873	Bit D4/4 L50/6 1FL UC MP (3x)	-
500-9874	Bit D4/4 L50/14 1FL UC MP (3x)	-
500-9875	Bit D6/2 L50/6 1FL UC MP (3x)	-
500-9876	Bit D6/3 L50/11 1FL UC MP (3x)	-
500-9877	Bit D6/4 L50/6 1FL UC MP (3x)	-
500-9878	Bit D6/6 L50/12 1FL UC MP (3x)	-
500-9879	Bit D6/3 L50/6 1FL DC MP (3x)	-
500-9880	Bit D6/4 L50/12 1FL DC MP (3x)	-
500-9881	Bit D6/6 L50/12 1FL DC MP (3x)	-
500-9882	Bit D6/2 L50/6 1FL UC A (3x)	-
500-9883	Bit D6/3 L50/6 1FL UC A (3x)	-
500-9884	Bit D6/3 L50/11 1FL UC A (3x)	-
500-9885	Bit D6/4 L50/8 1FL UC A (3x)	-
500-9886	Bit D6/4 L50/12 1FL UC A (3x)	-
500-9887	Bit D6/6 L50/12 1FL UC BAL A (3x)	-
500-9888	Bit D6/6 L58/22 1FL UC BAL A (3x)	-
500-9859	D6/6 L50/14 Polishing	-
500-0248	Collection bag 3flow (EU only)	
500-0257	Filter 3flow (EU only)	
500-0258	Carbon filter 3flow (EU only)	-
500-0259	Motor brush 3flow (EU only)	-
500-1797S	Replacement vacuum hose FXX30 (EU only)	-
500-3362	Hose D51 vac cleaner (EU only)	-

Part number	Description	Image
500-9331	Vacuum cleaner 1400w for router (EU only)	
500-9332	Vacuum cleaner bag (5x) for 500-9331 (EU only)	-
500-9347	5 bags for Hercules cleaner (EU only)	-
500-9348	Filter for Hercules cleaner (EU only)	
500-9349	Carbon filter for Hercules (EU only)	
500-9351	Replacement motor for Hercules (EU only)	-
KIT-5102	Router vacuum hose kit F1612 (EU only)	-



1.13 Consumables & Accessories for Rotary Module

Part number	Description	Image
500-9860	Decagonal knife D25 (3x) (tool: rotary module #500-9360)	-
500-9861	Decagonal knife D28 (3x) (tool: rotary module #500-9360)	-
500-9862	Decagonal knife D32 (3x) (tool: rotary module #500-9360)	-

1.14 General Accessories

Part number	Description	Image
1NC40-67034	Set of two 3" core holder for 16.5cm (6.5") roll diameter	
395-622	Set of two extended 3" core holders for 16.5 (6.5") roll diameter (EU only)	
500-0027	Fixnut toolhousing (EU only)	
500-0312S	POT brass guiding	
500-1116	Kit of 4 motor brushes (EU only)	
500-1255	Cam bellow	-
500-1261	Anti slip pad for media clamp	-
500-1302	Tool wrench	

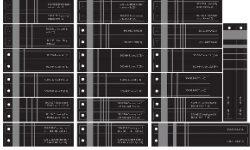
Part number	Description	Image
500-3313	Knife guide EOT	
500-3315S	Uni gliding disc SGL/DBL knife	
500-3325	Knife mounting tool V-cut packed	-
500-9117	Barcode labels kit 5051 (US only)	
500-3341S	POT assembly gliding disc (EU only)	-
500-9202	Remote controller pack including: Remote controller Sensor bar Battery charger	
500-9203	Battery charger (EU only)	
500-9225	Tilt fixture F1612	
500-9364	Replacement milling motor 1400W	-

Part number	Description	Image
500-9828	Gliding disc bevel-cut	-
KIT-5051	Barcode stickers (EU only)	
KIT-5109	Router extractor brushes	-
ND5000-8301	Pneumatic oil 1L (EU only)	

1.15 Sheet Feed 75 Consumables (EU only)

Part number	Description	Image
500-5080	Vacuum Filters Replacement Kit	-
500-5081	Flexible Fingers (5pcs)	-
500-5082	Vacuum Cup	-
500-5083	5 power fuses: 3x 6A, 2x 2A	-
500-5084	4x 24VDC fuse	-
500-5085	Lifter mat (no sensor window)	-
500-5086	Hydraulic oil 2L	-
500-5087	Brush stripe kit (8 pcs)	-