

F SERIES™

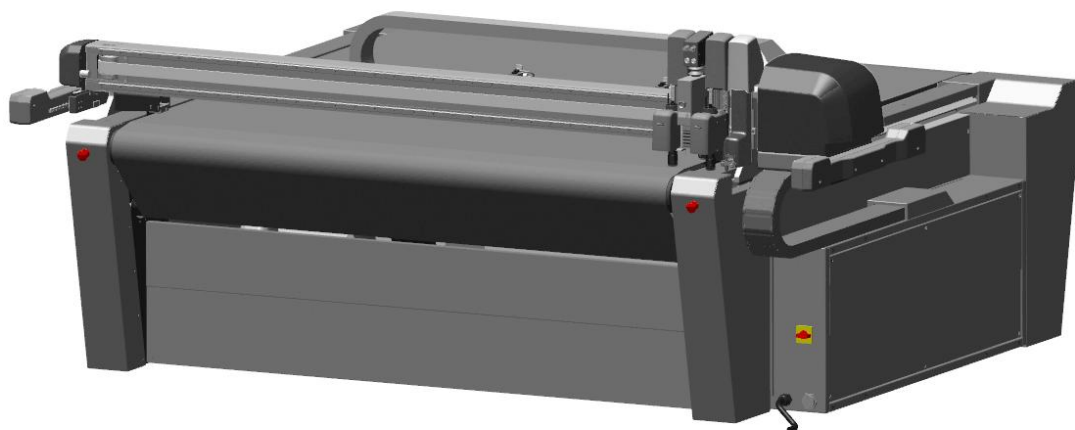

Reference guide
Rev 021d



FCC Notice

The F Series tables have been tested and found to comply with the limits for Class A digital devices, pursuant to Part 15 of the FCC Rules. These limits are designed to provide reasonable protection against harmful interference when the equipment is operated in a commercial environment. The cutters generate, use and can emit radio frequency energy, and if not installed and used in accordance with the instruction manual, may cause harmful interference to radio communications.

The user assumes the risk of any harmful interference caused by operating the cutters in a residential area.

Caution!

Changes or modifications, not expressly approved by Summa's FCC compliance, could void the user's authority to operate this equipment.

DOC Notice

The F Series do not exceed the Class A limits for radio noise for digital apparatus, set out in the Radio Interference Regulations of the Canadian Department of Communications.

Notice

Summa reserves the right to modify the information, contained in this User Manual, at any time without prior notice. Unauthorized copying, modification, distribution or display is prohibited. All rights reserved.

Waste Electrical and Electronic Equipment (WEEE) Directive

The symbol (right) is shown on this product. It indicates that the product should not be placed in municipal waste but should be disposed of separately. Electrical and electronic equipment can contain materials, which are hazardous to the environment and human health, and therefore should be disposed of at a designated waste facility or returned to your retailer for the appropriate recycling to take place.

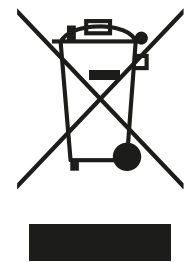

If you wish to dispose of this product and the product still functions, please consider recycling/reusing it by donating it to a charity shop, selling it or exchange parts of it with your retailer.

Registering the Flatbed Cutter

Please register the Flatbed Cutter on the following link:

<http://www.summa.be/registration.html>

Failure to register the cutter may result in a delayed response to warranty and service inquiries.

Contact Information

All inquiries, comments or suggestions concerning this and other Summa manuals should be directed to:

Summa, nv
Rochesterlaan 6
B-8470 GISTEL
Belgium

Website
www.summa.eu

Revision history

Version	Reason for modification	Publication date	Author
020	-	February 2023	WVRB
021	Added 2.3.5 Installing the corrugated tool Updated 2.4 Tool/knife calibration with ADC Added 2.5.1.5 Calibration of the corrugated tool Updated 2.5.1.6 Calibration of the V-cut tool Updated 2.5.1.7 Calibration of the bevel-cut knife Updated 5 Included accessories Updated Appendix	December 2024	WVRB, ALO
021b	Added 2.3.6 Removing the bottom part of the corrugated tool	June 2025	ALO
021c	Update 3.4 Poster Trim Update 4.1.2.11 Maintenance HF miller	September 2025	ALO
021d	Update 2.4 Tool/knife calibration with ADC (extra front margin: 80mm 110mm) Update 3.4 Poster Trim	November 2025	ALO

This manual is a reference guide for operating the F Series cutting table.

F SERIES™

Table of Contents

1	Machine components	1-1
1.1	Safety and Ideal Operating Environment	1-1
1.1.1	Safety	1-1
1.1.1.1	General	1-1
1.1.1.2	Symbols used in this manual	1-2
1.1.1.3	Safety precaution	1-2
1.1.1.4	Danger areas	1-3
1.1.1.5	Safety symbols on the machine	1-6
1.1.1.6	Safety Features	1-7
1.1.1.7	Personal protective equipment	1-8
1.1.2	Operating environment	1-8
1.2	Flatbed Components	1-9
1.2.1	Front view F1612	1-9
1.2.2	Rear View F1612	1-10
1.2.3	Larger models	1-11
1.3	Modules	1-12
1.3.1	Camera unit	1-12
1.3.2	Drag head module	1-13
1.3.3	Tangential module	1-14
1.3.4	Rotary Module	1-15
1.3.5	Standard router module (F Series router system optional)	1-16
1.3.6	HF Router module (F Series HF router system optional)	1-17
1.3.7	Remote Controller (optional)	1-18
1.4	Media Handling	1-19
1.4.1	General	1-19
1.4.2	Loading media on the F1612 with vacuum selector	1-20
1.4.2.1	Loading sheet media	1-20
1.4.2.2	Loading roll media	1-21
1.4.2.3	Setting origin and media size	1-23
1.4.3	Loading media on larger tables	1-25
1.4.3.1	Loading sheet media	1-25
1.4.3.2	Loading roll media	1-26
1.4.3.3	Setting origin and media size	1-28
1.5	Tools	1-30
1.5.1	Drag knife holder for the drag head module	1-30
1.5.1.1	Removing the knife from the drag knife holder	1-30

1.5.1.2	Installing the drag knife into the drag knife holder.....	1-30
1.5.2	Kiss Cutting Tool for the tangential module	1-31
1.5.2.1	Kiss Cutting Tool	1-31
1.5.2.2	Removing a knife from the Kiss Cutting Tool	1-31
1.5.2.3	Installing a knife from the Kiss Cutting Tool	1-32
1.5.3	Cutout Tool for tangential module	1-33
1.5.3.1	Types of cutout tools	1-33
1.5.3.2	Removing a knife from the Cutout Tool.....	1-33
1.5.3.3	Installing a knife in the Cutout Tool	1-33
1.5.4	Electronic Oscillating Tool (EOT) for the tangential module	1-34
1.5.4.1	EOT	1-34
1.5.4.2	Removing a knife from the EOT	1-34
1.5.4.3	Installing a knife in the EOT	1-35
1.5.5	Creasing tools for the tangential module	1-36
1.5.6	Corrugated tool for the tangential module.....	1-36
1.5.6.1	Corrugated tool.....	1-36
1.5.6.2	Removing a knife from the corrugated tool	1-36
1.5.6.3	Installing a knife in the corrugated tool.....	1-37
1.5.7	V-Cut tools for the tangential module.....	1-38
1.5.7.1	Types of V-Cut tools.....	1-38
1.5.7.2	Installing knives in the V-Cut tools	1-38
1.5.7.1	Bevel Cut tool	1-39
1.5.8	Perforating Tool.....	1-40
1.5.9	Pneumatic Oscillating Tool.....	1-40
1.5.9.1	General.....	1-40
1.5.9.2	Types of Pneumatic Oscillating Tool.....	1-41
1.5.9.3	Replacing a knife in the POT.....	1-42
2	Setting up modules / tools	2-1
2.1	Introduction.....	2-1
2.1.1	General remarks on the calibration of the tools	2-1
2.1.2	Automatic Depth Control	2-3
2.1.3	Tools in the accessory box.....	2-4
2.2	Installing / Removing a module.....	2-6
2.2.1.1	Installing a module	2-6
2.2.1.2	Removing a module	2-7
2.2.1.3	Rotary module	2-7
2.2.1.4	Router module	2-7
2.3	Installing Tools and knives.....	2-8
2.3.1	Installing Kiss Cutting Tool.....	2-8
2.3.2	Installing Cutout Tool	2-9
2.3.3	Installing EOT.....	2-10
2.3.4	Installing the Creasing Wheel	2-11
2.3.5	Installing the corrugated tool.....	2-12
2.3.6	Removing the bottom part of the corrugated tool	2-13
2.3.7	Installing the POT / POT-L.....	2-15
2.3.8	Installing the V-Cut tool.....	2-16
2.3.9	Installing the rotary perforating knife.....	2-17
2.3.10	Installing the Rotary Knife	2-18
2.3.11	Installing a router bit on standard miller	2-19

2.3.12	Installing a router bit on HF miller	2-21
2.4	Tool/knife calibration with ADC	2-24
2.4.1	General calibrations with the ADC	2-24
2.4.2	Practical tool changes with the ADC	2-27
2.4.2.1	Calibrating the Kiss Cutting Knife with the ADC	2-27
2.4.2.2	Calibrating the Cut Out Knives with the ADC	2-27
2.4.2.3	Calibrating the EOT with the ADC	2-28
2.4.2.4	Calibrating the Creasing Wheels with the ADC	2-28
2.4.2.5	Calibrating the corrugated tool with the ADC	2-29
2.4.2.6	Calibrating the POT with the ADC	2-29
2.4.2.7	Calibrating the V-Cut knives with the ADC	2-30
2.4.2.8	Calibrating the bevel-cut knife with the ADC	2-31
2.4.2.9	Calibrating the perforating knife with the ADC	2-32
2.4.2.10	Calibrating the Rotary knife with the ADC	2-32
2.4.2.11	Calibrating the routing bit with the ADC	2-33
2.5	Tool/knife calibration without ADC	2-34
2.5.1	Calibration of the tools/knives during first use	2-34
2.5.1.1	Calibration of the Kiss Cutting knife	2-34
2.5.1.2	Calibration of the Cutout knife	2-37
2.5.1.3	Calibration of the EOT	2-41
2.5.1.4	Calibration of the creasing tool	2-45
2.5.1.5	Calibration of the corrugated tool	2-47
2.5.1.6	Calibration of the V-cut tool	2-47
2.5.1.7	Calibration of the bevel-cut knife	2-51
2.5.1.8	Calibration of the perforating knife	2-56
2.5.1.9	Calibration of the POT	2-57
2.5.1.10	Calibration of the high torque rotary module	2-61
2.5.1.11	Calibration of the router module	2-64
2.5.2	Quick tool holder change without ADC option	2-66
2.5.2.1	Quick tool change for the Kiss Cutting Knife	2-67
2.5.2.2	Quick tool change for the cutout tools	2-67
2.5.2.3	Quick tool change for the EOT	2-68
2.5.2.4	Quick tool change for the V-Cut	2-68
2.5.2.5	Quick tool change for the POT	2-69
2.5.2.6	Quick tool change for the creasing tools	2-69
2.5.2.7	Quick tool change for the router	2-69
2.6	Quick depth adjust	2-70
2.6.1	General quick depth adjust	2-70
2.6.2	Quick depth check/adjust during a job	2-70
2.7	Calibration of the drag module	2-71
2.7.1	Calibration of the pen	2-71
2.7.2	Calibration of the knife	2-72
2.8	Calibration of the camera unit	2-73
3	Axis Control, remote & Plug-in	3-1
3.1	Axis Control	3-1
3.1.1	Main Window	3-2
3.1.2	Media menu	3-4

3.1.3	Change Tool.....	3-6
3.1.4	Reset.....	3-6
3.1.5	Modules.....	3-7
3.1.6	Load	3-7
3.1.7	Menu	3-8
3.1.8	Events	3-15
3.1.9	Reboot.....	3-15
3.1.10	Color Axis Control icon.....	3-16
3.1.11	Axis Control options when table is busy cutting jobs from Summa GoProduce.....	3-16
3.2	Remote control (optional).....	3-17
3.2.1	Wireless Bar setup	3-17
3.2.2	Name of the buttons on the remote	3-17
3.2.3	Setting the origin and size with the remote	3-18
3.2.4	Setting the tool/knife up and down position with the remote.....	3-19
3.2.5	Switching vacuum pump on/off	3-19
3.3	Plug-ins.....	3-20
3.3.1	Plug-in for Illustrator (PC).....	3-20
3.3.2	Plug-in for Corel (PC).....	3-21
3.3.3	Plug-in for Illustrator for Mac (from CS4 up)	3-22
3.4	Poster Trim.....	3-23
4	Maintenance and Cleaning.....	4-1
4.1	General Information	4-1
4.1.1	Daily maintenance.....	4-1
4.1.2	Weekly/monthly maintenance	4-1
4.1.2.1	Cleaning the nose piece (Kiss Cutting Knife only)	4-2
4.1.2.2	Cleaning the gliding disk (Cutout and EOT).....	4-2
4.1.2.3	Replacing the knife guide of the EOT	4-3
4.1.2.4	Cleaning the conveyor belt or protective mat.....	4-4
4.1.2.5	Cleaning the protection brushes at the sides	4-4
4.1.2.6	Cleaning Guide rails	4-4
4.1.2.7	Emptying the compressed air filter on machines without a POT	4-4
4.1.2.8	Filling up oil supply on machines with a POT.....	4-4
4.1.2.9	Cleaning the ADC.....	4-5
4.1.2.10	Cleaning collet of the standard router	4-5
4.1.2.11	Maintenance HF miller	4-6
5	Included accessories	5-13
5.1.1.1	F1432 (EU).....	5-13
5.1.1.2	F1432 (US).....	5-13
5.1.1.3	F1612 (EU).....	5-14
5.1.1.4	F1612 (US).....	5-14
5.1.1.1	F1612 (US) Single Phase.....	5-15
5.1.1.1	F1625 (EU).....	5-16
5.1.1.2	F1625 (US).....	5-16
5.1.1.3	F1832 (EU).....	5-17
5.1.1.4	F1832 (US).....	5-17
5.1.1.5	F3220 (EU).....	5-18
5.1.1.6	F3220 (US).....	5-18

5.1.1.7 F3232 (EU).....5-19
5.1.1.8 F3232 (US).....5-19

List of Figures

1-1 General danger area	1-3
1-2 Safe working area.....	1-4
1-3 Danger area around the head	1-5
1-4 F1612 Front view.....	1-9
1-5 F1612 rear view.....	1-10
1-6 External vacuum pump large table.....	1-11
1-7 Setting origin on F1612 with vacuum selector	1-19
1-8 Setting origin on F1612 with vacuum zones	1-19
1-9 Serial number F series (found just above ON/OFF switch).....	1-19
1-10 Options for loading sheet material.....	1-20
1-11 Options for loading roll material.....	1-21
1-12 Media core holder.....	1-22
1-13 Options for setting the origin	1-23
1-14 Options for setting the size.....	1-24
1-15 Options for loading sheet material.....	1-25
1-16 Options for loading roll material.....	1-26
1-17 Media core holder.....	1-27
1-18 Options for setting the origin	1-28
1-19 Options for setting the size.....	1-29
1-20 Removing the knife from the standard drag knife holder	1-30
1-21 Knife length adjustment.....	1-30
1-22 Kiss Cutting tool.....	1-31
1-23 Knife holder Kiss Cutting tool	1-31
1-24 Removal of the Kiss Cutting knife	1-31
1-25 Blade assembly Kiss Cutting Tool.....	1-32
1-26 Knife depth adjustment Kiss Cutting tool	1-32
1-27 Single edge cutout tool.....	1-33
1-28 Double edge cutout tool	1-33
1-29 Heavy Duty cutout tool	1-33
1-30 Electronic oscillating tool	1-34
1-31 Knife holder shaft – Setscrew removed from EOT.....	1-35
1-32 Knife in EOT	1-35
1-33 Creasing tools.....	1-36
1-34 Corrugated tool.....	1-36
1-35 Removing the knife from the corrugated tool	1-37
1-36 Installing the knife from the corrugated tool	1-37
1-37 V-Cut tools.....	1-38
1-38 Installing knives in the V-Cut tools	1-38
1-39 Bevel CUT tool.....	1-39
1-40 Perforating tool	1-40
1-41 POT	1-41
1-42 Types of Pneumatic asclilating tools	1-41
1-43 Knife POT	1-42
2-1 ADC right side	2-3
2-2 Hex screwdriver 4 mm.....	2-4
2-3 Hex Screwdriver 2.5 mm	2-4
2-4 Wrench #10 mm	2-4
2-5 Tool wrench	2-5
2-6 Hex key 1.5 mm.....	2-5

2-7 Hex key 2 mm.....	2-5
2-8 Installing/Removing a module	2-6
2-9 Installing/Removing a module	2-6
2-10 Electric connector	2-7
2-11 Connector for larger tables	2-7
2-12 Connector for F1612	2-7
2-13 Insert the Kiss cutting tool	2-8
2-14 Insert the Cutout tool	2-9
2-15 Mounting the EOT	2-10
2-16 Insert the Creasing wheel.....	2-11
2-17 V-Cut tool in two parts	2-12
2-18 Install the upper part of the V-Cut tool	2-12
2-19 Install the bottom part of the V-Cut tool.....	2-12
2-20 Mounting the POT	2-15
2-21 V-Cut tool in two parts	2-16
2-22 Install the upper part of the V-Cut tool	2-16
2-23 Install the bottom part of the V-Cut tool.....	2-16
2-24 Perforating tool in two parts.....	2-17
2-25 Install the upper part of the Peforating tool	2-17
2-26 Install the bottom part of the Perforating Knife	2-17
2-27 Change knife Rotary module	2-18
2-28 Place new knife in Rotary module	2-18
2-29 Milling motor	2-19
2-30 Taking the miller out of the router module.....	2-19
2-31 Router bit position on the collet	2-20
2-32 Start position extractor brush	2-20
2-33 HF Milling motor	2-21
2-34Brush position for bit change	2-22
2-35 Switch for bit change	2-22
2-36 Switch for bit change	2-22
2-37 Setting the up position with the ADC.....	2-24
2-38 Checking the cutting depth.....	2-25
2-39 Knife orientation in thick material	2-26
2-40 Test pattern cutout tool – Blade compensation parameter	2-26
2-41 Setting of Creasing depth parameters	2-28
2-42 Flute direction corrugated cardboard	2-28
2-43 Setting of Creasing depth parameters	2-29
2-44 Correct V-Cut.....	2-30
2-45 Correct Bevel-cut.....	2-31
2-46 Calibration distance Router module - camera	2-33
2-47 Up/down parameters Kiss Cutting tool	2-34
2-48 Setting the down parameter Kiss Cutting tool	2-34
2-49 Setting of knife parameters – Kiss Cutting tool	2-35
2-50 Test pattern Kiss Cutting tool Origin Parameter.....	2-35
2-51 Origin pattern test for the Kiss Cutting knife.....	2-36
2-52 Test pattern Kiss Cutting tool Lateral parameter.....	2-36
2-53 Test pattern Kiss Cutting tool Longitudinal parameter	2-37
2-54 Up/down parameters Cutout tool.....	2-38
2-55 Setting knife parameters Cutout tool	2-38
2-56 Origin pattern test for the Cutout knife	2-39
2-57 Lateral pattern test for the Cutout knife	2-39

2-58	Longitudinal pattern test for the Cutout knife	2-40
2-59	Origin pattern test for the Kiss Cutting knife.....	2-40
2-60	Test pattern Cutout tool Blade compensation parameter	2-41
2-61	Up/down parameters Cutout tool.....	2-41
2-62	Setting knife parameters EOT	2-42
2-63	Origin pattern test for EOT	2-43
2-64	Lateral pattern test for EOT	2-43
2-65	Longitudinal pattern test for EOT	2-44
2-66	Origin pattern test for the Kiss Cutting knife.....	2-44
2-67	Test pattern Cutout tool Blade compensation parameter	2-45
2-68	Settings of Creasing parameters.....	2-45
2-69	Settings of Creasing depth parameters.....	2-46
2-70	Flute direction Corrugated cardboard	2-46
2-71	Setting of Creasing depth parameters	2-47
2-72	Up/down parameters V-Cut.....	2-48
2-73	Test pattern knife depth test V-Cut.....	2-48
2-74	Setting knife parameters V-Cut	2-48
2-75	Origin pattern test for V-Cut knife.....	2-49
2-76	Lateral pattern test for V-Cut knife	2-49
2-77	Longitudinal pattern test for V-Cut knife.....	2-50
2-78	Up/down parameters bevel-cut	2-51
2-79	Test pattern knife depth test BEVEL-Cut	2-52
2-80	Setting knife parameters bevel-Cut.....	2-52
2-81	Origin pattern test for bevel-Cut knife	2-53
2-82	Lateral pattern test for bevel-Cut knife	2-54
2-83	Longitudinal pattern test for bevel-Cut knife.....	2-55
2-84	Adjusting knife depth perforating Knife	2-56
2-85	Setting knife parameters EOT	2-57
2-86	Origin pattern test for EOT	2-58
2-87	Lateral pattern test for EOT	2-58
2-88	Longitudinal pattern test for EOT	2-59
2-89	Origin pattern test for the Kiss Cutting knife.....	2-59
2-90	Test pattern Cutout tool Blade compensation parameter	2-60
2-91	Up/down parameters Rotary module	2-61
2-92	Setting knife parameters Rotary module.....	2-62
2-93	Origin pattern test for the Rotary knife	2-62
2-94	Lateral pattern test for the Rotary knife.....	2-63
2-95	Longitudinal pattern test for the Rotary knife	2-63
2-96	Correct height extractor brush.....	2-64
2-97	Ring to set the vacuum strength.....	2-65
2-98	Calibration distance Router module - Camera	2-65
2-99	Parameters pen.....	2-71
2-100	Parameters Drag knife	2-72
2-101	Test pattern Drag knife.....	2-72
2-102	Calibration distance module origin - Camera	2-73
3-1	Axis Control confirmation for startup	3-1
3-2	Axis Control Main window	3-2
3-3	Media menu.....	3-4
3-4	Loaded media large table.....	3-5
3-5	Tool change menu.....	3-6
3-6	Reset button	3-6

3-7 Tool calibration menu (module menu).....	3-7
3-8 Load menu.....	3-7
3-9 Parameter menu.....	3-8
3-10 Event menu	3-15
3-11 Plug-in for Illustrator on Mac	3-22
4-1 Nose Piece Kiss Cutting Tool.....	4-2
4-2 Gliding surface.....	4-2
4-3 Knife guide with screws for removing and replacing	4-3
4-4 Usage of an extra tool if the knife guide grips in the shaft	4-3
4-5 ADC cleaning.....	4-5
4-6 Collet miller	4-5
4-7 Modules menu HF Miller with burn-in button.....	4-7
4-8 Windows run-in cycle	4-7
4-9 Switch for bit change	4-8
4-11 Collet with setscrew.....	4-8
4-10 Removing collet from the miller	4-9
4-12 Cleaning the collet.....	4-9
4-13 Re-install the collet from the miller	4-10
4-14 Switch for bit change	4-11
4-15 Removing collet from the miller	4-11
4-17 Re-install the collet from the miller	4-12

1 MACHINE COMPONENTS

1.1 Safety and Ideal Operating Environment

1.1.1 Safety

1.1.1.1 General

The purpose of the user's manual is not only to explain the operating procedures in order to operate this machine. It also provides the owner, users and operators with precaution procedures for safe and proper machine operation for its intended purpose.

All information in this manual must be read and understood before any attempt is made to operate the machine.

The manufacturer has no direct control over the machine operation and application. Proper safety practice is the sole responsibility of the owner, user and operator.

All instructions and safety warnings in this manual are based upon the use of this machine under proper operating conditions without alterations from the original design.

The proper use and the limits of the application of the cutting table depend on the module and tool, used in combination with the material.

Any use of the flatbed that is beyond the capabilities of the combination tool/material is considered as improper use and may result in injury and/or serious damage to the machine and will lead to loss of warranty.

The installation of the machine, accessories and spare parts must not be done by untrained or unauthorized persons. Also the described maintenance procedures need to be followed and performed by trained personnel.

1.1.1.2 Symbols used in this manual



Warning with dark (red) symbol: Refers to immediate threat that can cause serious injuries and effects on health and safety.



Warning with light (yellow) symbol: Refers to a dangerous situation that can cause injuries and serious damage to the machine.



Attention with dark (red) symbol: Refers to useful information to prevent damage to the equipment and prolong the service life of the machine.



Attention with light (yellow) symbol: Refers to useful tips to enhance the user-friendliness and make the work significantly easier.



Note: Can be considered as a general tip, something that is useful to know.

1.1.1.3 Safety precaution



WARNING: This equipment is not suitable for use in locations where children are likely to be present.



WARNING: The F series cutters use razor-sharp tools. Touching the tools with bare hands may cause injury. Do not touch the tools while the machine is cutting.

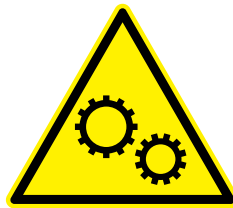

WARNING: There is a risk of injury from being caught or trapped in moving machine parts.
Keep hands, hair, clothing and jewellery away from moving parts. Do not wear jewellery, loose clothing, scarves, open jackets or shirtsleeves.

1.1.1.4 Danger areas

- *GENERAL DANGER AREA*

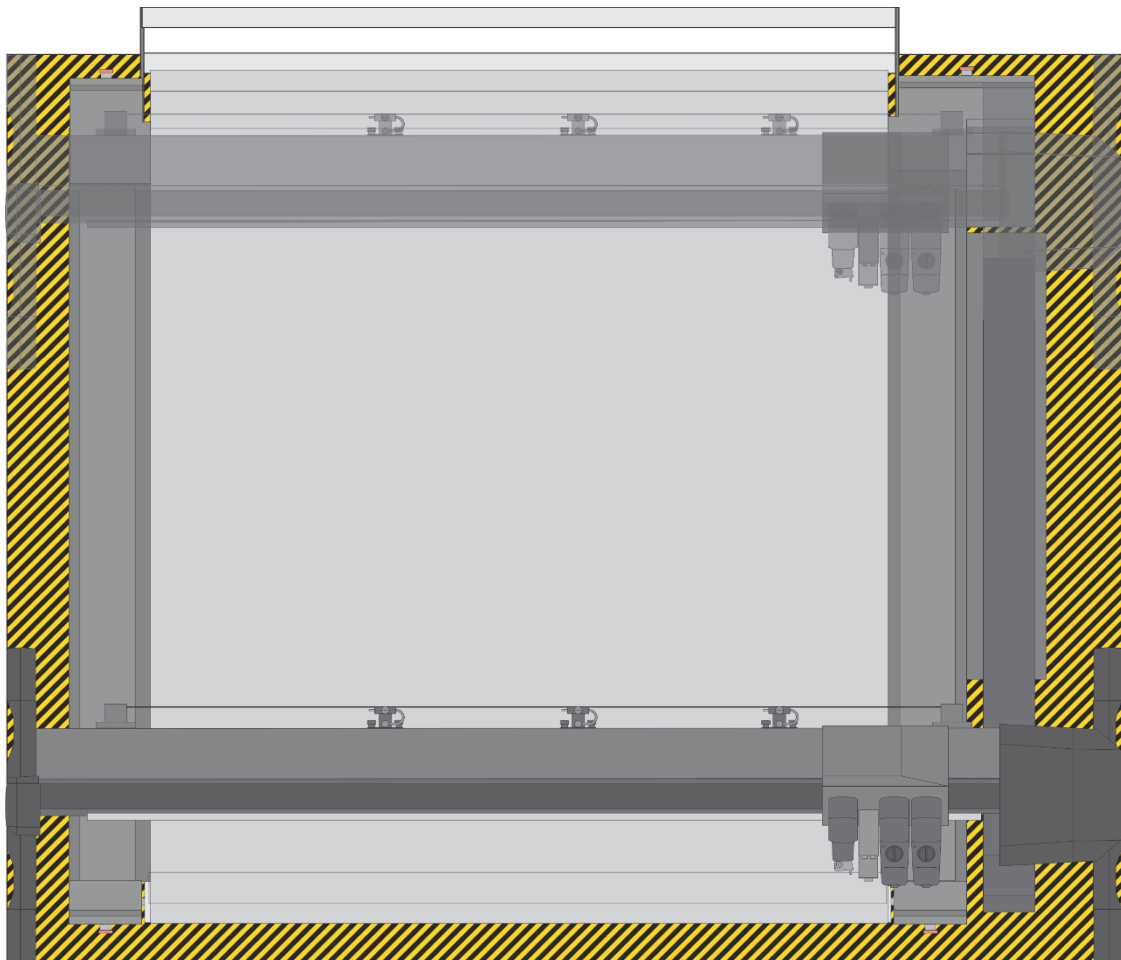

FIG 1-1
GENERAL DANGER AREA

The easiest way to define the general danger area is the complete area where the table itself stands and which also covers the moving parts.



WARNING: The top beam is wider than the table itself. This means that the danger area is wider than the table itself. On the figure the top beam is shown in the most furthest to the front of the machine. The maximum rear position is shown in a lighter color. This results in the general danger area which is marked with yellow/black striped pattern.

- SAFETY AREA DURING OPERATION

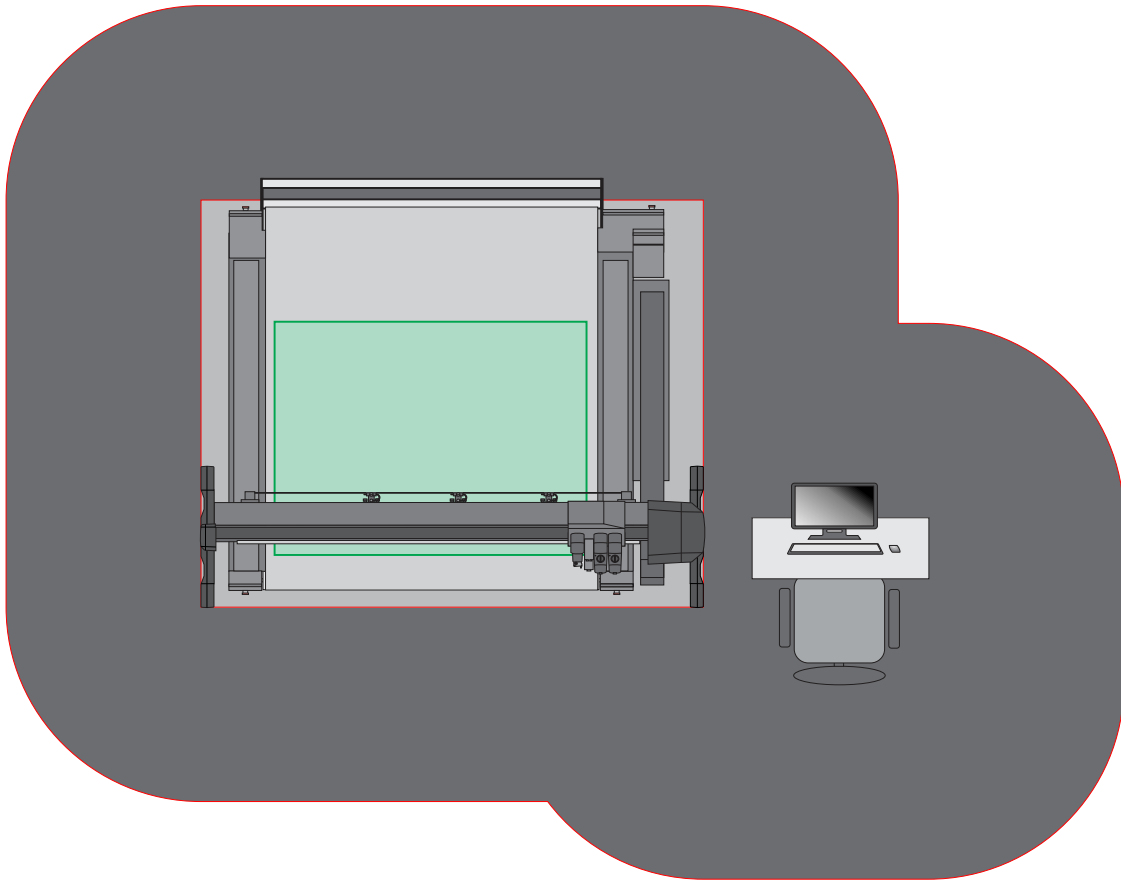

FIG 1-2
SAFE WORKING AREA

During normal production the operator should stay out of the area marked in light gray color. If the operator moves inside this area, then trip switches or optical sensors can detect the presence of the operator and then the flatbed table pauses automatically. The current job is not lost but nothing will move on the table until the operator leaves the area and tells the flatbed cutter to continue its job (with Axis Control).



WARNING: If the operator needs to be within the area, marked in light gray to change media or tools, the procedures to perform these actions need to be followed strictly, as described further in the manual.

The safety area for other personnel is marked in dark gray. It covers 1 meter outside the danger area and 1 meter away from the operator's desk.



WARNING: he operator must always make sure the remote is in its loading station when it is not in use. This way no other personnel will inadvertently press the buttons and start up the machine while the operator is in the danger area.

- **DANGER AREA AROUND THE HEAD**

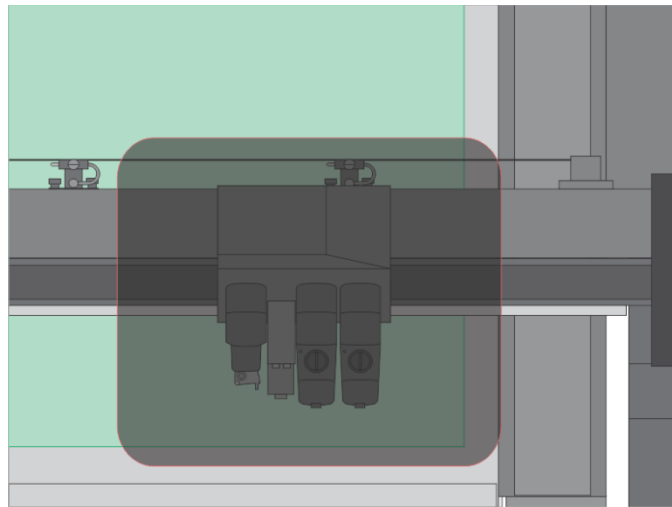



FIG 1-3
DANGER AREA AROUND THE HEAD

The head with the modules and about 20 cm around it can be considered as the extra danger area during module/tool installation. When the operator is working within this area, he has to be extra careful.

When a module or a tool needs to be changed, the operator is obliged to perform certain actions within the danger area around the head. So the operator must be sure that the machine will not make any unexpected movement while performing the changes. There are only two possible ways to be sure the machine will not make any sudden movements: either changing the module/tool while the machine is switched off, or following the module/tool change procedure.

WARNING: When changing a module or a tool, always make sure that Axis Control



is initiated and check whether the second button in Axis Control is . If it is , then click it, so the machine comes off line and will not move any more.

1.1.1.5 Safety symbols on the machine

Safety labels are used on some parts of the machine. They are explained below.



Warning label for possible electric shock. Only a licensed electrician can open the parts of the machine containing these labels.



Warning label for hot surface. During operation, surfaces may become hot with a risk of burning when touching.



Hazard Label "Laser Radiation". This machine has a Class 2 laser pointing device, do not look directly into the light beam.



Warning for risk of hearing loss if exposed when the machine is operating for a long time without hearing protection.



Warning for risk of injury because there are moving parts.

Make sure to observe all the caution labels on the table.

There are no user-serviceable parts inside. For servicing refer to qualified personnel only. Turn off the table and contact a service representative in any of the following cases.

- There is visible mechanical damage.
- The power cord is damaged.
- The table (or parts of it) have been damaged by an impact
- Liquid was spilled on the table.
- There is a strange noise, smoke or an unusual smell coming from the table.

1.1.1.6 Safety Features

- *CONTROLLED START UP*

The table will not start up when it just switched on. Before the machine is switched on, it has to be connected with the computer and the program axis control has to be running. A short time after the machine is powered on, a message will appear in axis control on the computer asking the operator for confirmation to start up (see section 3.1).

- *BUMPERS ON TOP BEAM*

On the left and right side of the top beam there are bumpers with trip switches that can detect if an operator is standing in the way of the path the top beam will move. When something pushes against it the table will stop moving.

- *LIGHT BARRIER*

A safety beam is created from left to right along the top beam with optical sensors mounted in the bumpers. If the light beam is interrupted, then the machine stops. The interruption is a controlled stop. The machine will stop the movement in less than five seconds and hold the position where it stopped. This means that the machine can continue the job when enter is pressed.

- *EMERGENCY STOP SWITCHES*

There is an emergency switch on each corner of the flatbed table. This allows the operator to switch off the machine quickly in hazardous situations. If the emergency stop is pressed, the power to the motors is cut immediately. This means that the machine stops immediately, but it also means the current job is lost.

To unlock an activated emergency switch, turn it clockwise.

- *OVERCURRENT*

The cutter constantly measures the current through the motors. If the machine detects the current is too high, the current is cut off to the motors and a fatal error message will be displayed in Axis Control.



WARNING: All the built-in safety features cannot prevent the high level of kinetic energy that can be released during an emergency stop or an unforeseen malfunction of the machine. So they are not a guarantee against injuries.

1.1.1.7 Personal protective equipment

The required safety equipment depends on the installed modules and the material that needs to be cut/milled.

During operating or servicing the machine the operator should wear close fitting clothing and use appropriate protective equipment.

Appropriate protective equipment can include:

- Work clothes.
- Goggles because when processing the material large particles can be generated.
- Ear protection if the continuous sound level pressure is above 80dB.



WARNING: There is a risk of injury from being caught or trapped in moving machine parts.

Keep hands, hair, clothing and jewelry away from moving parts. Do not wear jewelry, loose clothing, scarves or open jackets or shirtsleeves.

1.1.2 Operating environment

Environmental conditions can significantly affect the machine's performance. Most restrictions or recommendations for the ideal operating environment are already described in the site preparation document.

The environmental conditions of the machine (without media) are as follows:

Operating Temperature	15 to 35° C	59 to 95° F
Storage temperature	-30 to 70° C	-22 to 158° F
Relative humidity	35 - 75 %, non-condensing	35 - 75 %, non-condensing

It is possible that the environmental conditions of the used media are stricter than those of the machine itself. Please refer to the documentation about the used media. Also make sure that the media has had enough time to acclimatize.

1.2 Flatbed Components

1.2.1 Front view F1612

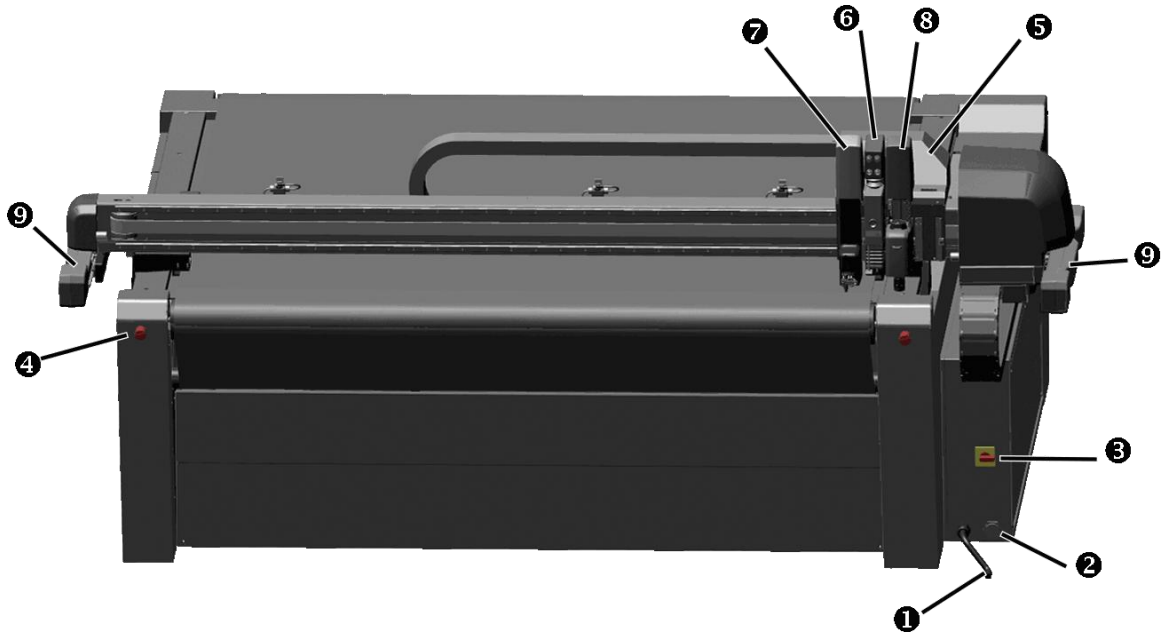

FIG 1-4
F1612 FRONT VIEW

1. **Power cable entry:** The F1612 has no power entry plug. The power cable has to be made onsite and it has to be connected directly inside the machine itself. The cable will have to be guided through this entry.
2. **USB connection:** This interface is based on the standards, specified in the Universal Serial Bus. A minimum of USB 2.0 is needed for the camera connection.



ATTENTION: The F1612 needs to be connected directly to a computer. The USB cable shouldn't be longer than 3 meter (+0.5 m) and no hubs should be used.

3. **Power On/Off switch:** This turn switch can be used to switch the flatbed on or off. There is a hole provided, so the switch can be locked with a padlock.
4. **Emergency stops:** There are four emergency stops on the flatbed. If they are pressed, the flatbed stops immediately to prevent damage to the operator and to the machine itself. Once pressed, they stay in a safe locked position and need to be turned to the right to unlock again.
5. **Carriage for modules:** The carriage can hold up to three removable modules and has a fixed central unit.
6. **Central unit:** The central unit houses a positioning laser and an integrated camera system for fast and accurate registration mark recognition.
7. **Drag head module:** The drag head module comes standard with the flatbed cutter. It can be used to mount the drag knife or pen.
8. **Tangential module (optional):** The tangential module is used for the tangential tools.
9. **Safety bumpers:** These bumpers have trip switches and optical sensors to detect the presence of the operator so the machine stops when the operator is too close.

1.2.2 Rear View F1612

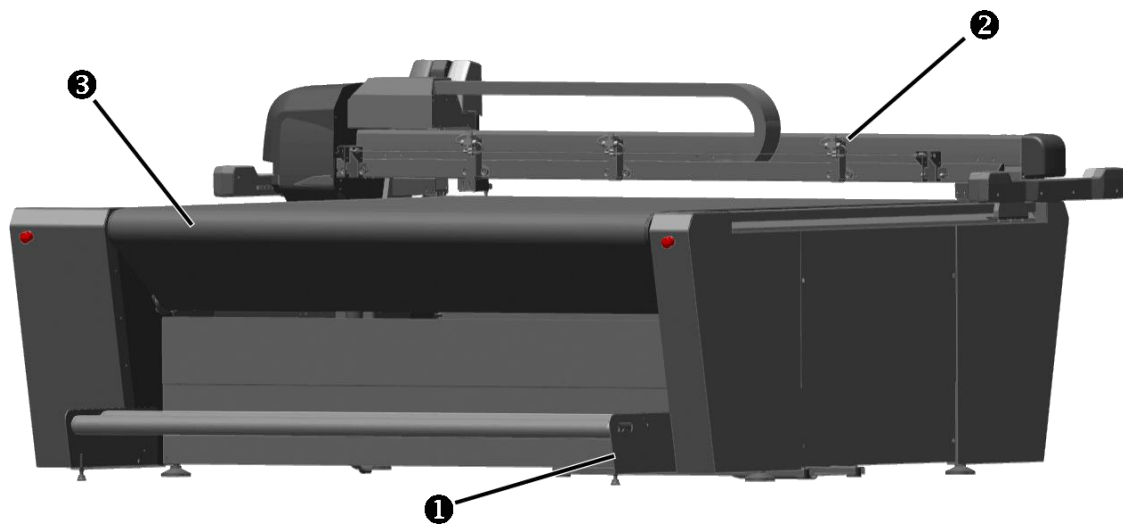



FIG 1-5
F1612 REAR VIEW

1. **Roll support:** Media support bars and a set of core holders for loading roll material.
2. **Pneumatic clamps:** Pneumatic media advance system. It clamps the conveyor belt and holds the media down while pulling it forward in order to work continuously, in panels or for multiple jobs.



NOTE: The three clamps that hold the media down can be moved from the left to the right and can be enabled () or disabled () individually by turning the handle on top of each clamp.



NOTE: If the media does not stay flat after feeding, it is recommended to only use one media clamp in the middle of the media.

3. **Conveyor belt:** The conveyor system is needed for feeding the media when the cutout tool is used.



NOTE: If oscillating tools are used, then a protective mat can be put over the conveyor belt. However, with the protective mat the maximum size of the job is restricted to the size of the table.

General Directional information:

- Front right of the machine: Where the on/off switch is located (this determines automatically the left and back of the machine).
- X axis: From front to back.
- Y axis: From right to left.
- Origin: The origin is situated at the right side at the front.

1.2.3 Larger models

The larger models have basically the same components. There are however a couple of differences.

The vacuum pump(s) are not located under the table, but they can be set either next to or at the distance (for noise reduction). Some larger models have one external pump, other have two (depending on the size of the table).

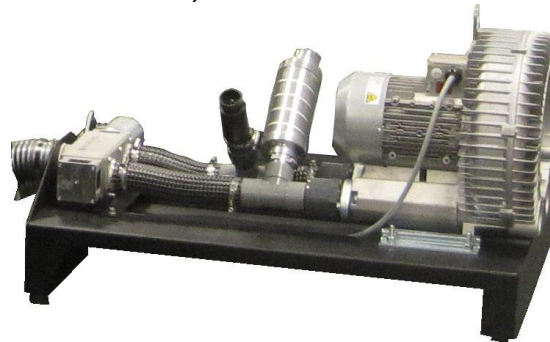

FIG 1-6
EXTERNAL VACUUM PUMP LARGE TABLE

The flatbed surface is divided into a number of zones, the number of zones depends on the size of the table. The zones are switched on/off according to the set media size.

1.3 Modules

1.3.1 Camera unit



Up to three modules can be mounted on the carriage. The carriage also has a central unit. This central unit is fixed to the carriage and cannot be taken off. The central unit houses a positioning laser and an integrated camera system for fast and accurate registration mark recognition while contour cutting.

The camera module also has two optional connections for electricity for special tools or modules.

The camera module of the F1612 also has the connections for the special tools or modules that require compressed air. For the larger models, these connections for compressed air are situated at the side of the carriage.

Both the knob and black camera adjust plate are part of the manual height adjust mechanism. Each time material is loaded with a different thickness than the previous one, the height of the camera needs to be adjusted (only with contour cutting).

To adjust the height do following:

1. Make sure the central unit is situated above the media.
2. Turn the knob counterclockwise to loosen the central unit and let it move all the way to the top.
3. Push the central unit all the way down.
4. Push the camera adjust-plate down onto the media.
5. Let go of the central unit whilst the adjust plate stays pushed on the media.
6. Secure the central unit by turning the knob clockwise and let go of the adjust plate.

1.3.2 Drag head module



The drag head module comes standard with the flatbed cutter.

The Drag Module is a fast-moving drag knife and pen holder for making notations or kiss-cutting a wide range of materials, using up to 600 grams of downforce.

The clearance between the standard drag knife holder and the flatbed base is approximately 3 mm (0.11"). So, it has to be removed when thicker materials are used. The clearance between the table and the drag head module is less than 1 cm (0.4"), so if thicker materials are used, the drag head module must be removed or the height of the head must be changed.



ATTENTION: It is recommended to remove the module when not in use.

The height of the drag head can be changed manually. However for 99% of the cut jobs with the drag head, the height will not have to be changed. The height of the drag head needs to be changed only if it is used for writing on thick materials.

To change the height of the drag head do following:

1. Remove the drag head module from the flatbed.
2. At the back of the module, loosen the 4 screws in the 4 slots.
3. Move the head to the desired height.
4. Fasten the 4 screws again.
5. Put the module back on the flatbed and check if the new height is correct. If not, repeat this procedure.

1.3.3 Tangential module



The tangential module offers a vertical force of 10 kg and corresponds to a wide range of matching tools. Each tool has a barcode ID that ensures automatic recognition and separate parameter settings.

For each application, a corresponding tool can be installed on the tangential module.



ATTENTION: It is recommended to remove the module when not in use.

Currently following tools are available:

1. Kiss cutting tool
2. Cutout tool (single, double and heavy duty)
3. EOT (electronic oscillating tool)
4. Creasing tool
5. V-Cut tool
6. POT (pneumatic oscillating tool)

The flat front knob serves to hold the internal shaft steady whilst installing or removing a tool. This is explained in detail in the next section.

1.3.4 Rotary Module

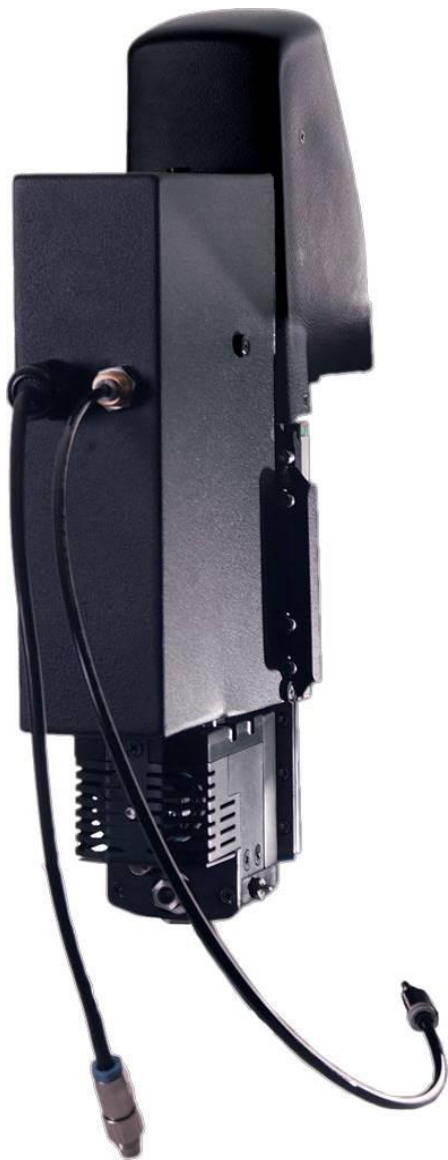

The Rotary Module has a decagonal tangentially controlled knife, which is driven by an electronic motor.

Depending on the used speed and knife diameter, all kinds of materials up to 5 mm thickness can be cut with the rotary knife.

However, the main focus is on single layered textiles because certain types of fiber are hard to cut with other knife types. Ideal materials to cut with the rotary knife are: flag & banner material, felt, technical textiles, fabric, foams,...

The module allocates slot 2&3 of the head. It also requires compressed air (standard on large tables).

Knives have to be mounted directly in the module; there are no tools available for this module.

The Rotary module includes the following:

1. Rotary module
2. Connection for compressed air for large and small tables
3. Knife \varnothing 28 mm
4. Wrench # 10 mm for knife change

1.3.5 Standard router module (F Series router system optional)



The router module has a 1 kW standard motor capable of handling most used solid boards in the graphic and sign industry: hard foam PVC, acrylic and aluminum covered foam boards.

The router system comes with a vacuum cleaning kit to take away the chips and dust. The kit includes a brush assembly, a hose and a mounting pole. The vacuum cleaner is optional.

The module allocates slot 2&3 of the head. Of course, the module can be easily dismantled and parked on the pole of the gantry, making the two slots available again.

The hose set and gantry of a small table are not the same of those of a big table. So be sure to check the option list of the table model to be sure the correct router module is ordered for the table.

The F Series router system includes following:

1. Routing module (with brush system)
2. Hoses and gantry
3. Switch for vacuum cleaner
4. Milling Motor
5. Set of collets
6. Universal bit to start with
7. Milling mat



ATTENTION: Use of a routing mat is mandatory.

1.3.6 HF Router module (F Series HF router system optional)



With up to 1 kW output power the HF milling motor has significantly more power than the standard milling motor, which allows faster processing speeds.

The balanced spindle also generates higher rotation speeds. This also allows faster processing speeds and/or smoother finishing.

The HF router system comes with an own power supply and motor driver, which are mounted on the pole of the gantry system outside the machine.

The collet is clamping the bit pneumatically. No wrenches are needed to replace the bit. While in change tool/bit mode, a compressed air switch activates and deactivates the clamping of the bit. This can be done while the milling motor remains in the module, which results in fast and easy bit changes.

The router system comes with a vacuum cleaning kit to take away the chips and dust. The kit includes a brush assembly, a hose and a mounting pole. The vacuum cleaner is optional.

The hose set and gantry of a small table are not the same of those of a big table. So be sure to check the option list of the table model to be sure the correct router module is ordered for the table.

The F Series HF router system includes following:

1. Routing module (with brush system)
2. Hoses and gantry
3. Switch for vacuum cleaner
4. SycoTec Milling Motor
5. Power supply and motor driver
6. Collet: 6 mm
7. Universal bit (\varnothing 4mm) to start with
8. Milling mat



ATTENTION: Use of a routing mat is mandatory.

1.3.7 Remote Controller (optional)



The remote controller can be used in combination with the program Axis Control.

It is useful during media loading and tool installation while moving around the flatbed cutter.

The arrow keys work in the same way as the arrow keys on the keyboard.

The A key is the acknowledge key, which needs to be used when a setting has been changed.

The key at the back of the remote (B key) is the same as the shift key on the keyboard.

The lights at the bottom show the number of the module that is chosen during the calibration of the tools.

The left light is blinking during origin change and the right light is blinking during media size change.

See table below for complete list of Wii buttons / keyboard keys

Refer to section 3.2.1 for activation of the remote controller.



ATTENTION: Be sure to put the remote controller on its loading station each time it has been used. If the computer stays activated at night, you should stop the connection between the computer and remote.



WARNING: If the remote is used during tool calibration, the operator can approach the table. The operator must make sure that at that moment nobody else is in the neighbourhood of the table or computer (see safety area in section 1.4.5.3).

Wii Remote key	Corresponding Keyboard key
ARROW buttons	ARROW keys
'A' button	ENTER
'Back' button	SHIFT
'-' button	PAGE DOWN and NUMLOCK SUBTRACT (version 3.14)
'Home' button	ESCAPE
'+' button	PAGE UP and NUMLOCK ADD (version 3.14)
'1' button	F1
'2' button	F2

Shortcut Keyboard key	Functionality
'P'	Select pointer when setting origin or size.
'C'	Select camera when setting origin or size.

1.4 Media Handling

1.4.1 General

When media is loaded on the F series, the working area has to be set. This is done with Axis Control.

Once the working area is set, the F series automatically adjust the vacuum zones for the best vacuum. There are two systems.

The F1612, built before February 2023, have a vacuum selector which adjusts the vacuum width automatically after the working area is set with Axis Control. The vacuum zone can be set continuously and the origin of the media needs to always at the lower right of the table surface.

The F1612 built after that date and all the larger F series tables work with vacuum zones that will be switched on or off after the working area is set with Axis Control. The origin of the working does not need to be at the lower right of the table surface, it can be set at any lower right position of the vacuum zone. The zones are made visible with Axis Control.

The difference between an F1612 with a vacuum selector or an F1612 with vacuum zones can easily be seen when setting the working area. Machines with vacuum zones show the vacuum zones with green lines, machines with vacuum selector show no green lines. See screenshot below (taken when setting the origin).

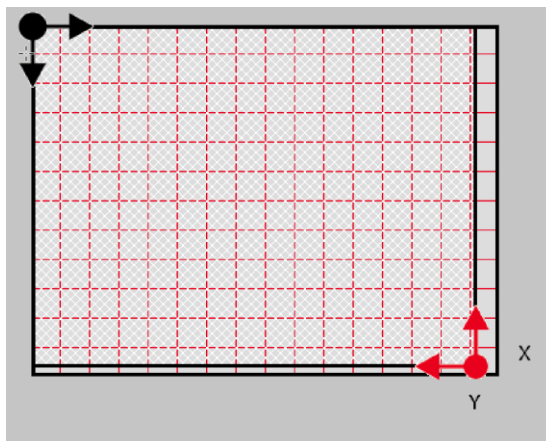

FIG 1-7
SETTING ORIGIN ON F1612 WITH VACUUM
SELECTOR

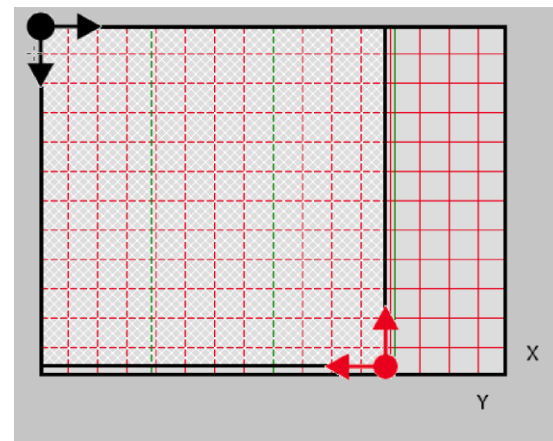

FIG 1-8
SETTING ORIGIN ON F1612 WITH VACUUM
ZONES

The two different types of F1612 can also be recognized by their model number. Check the serial number label for this. F1612 with vacuum selector are the models F1612-1X, F1612-2X and F1612-3X. Currently the F1612 with vacuum zones has as model reference F1612-4X.

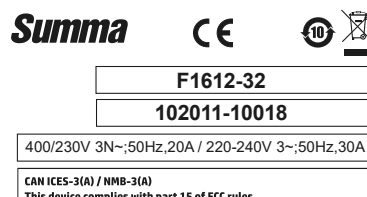

FIG 1-9
SERIAL NUMBER F SERIES (FOUND JUST ABOVE ON/OFF SWITCH)

1.4.2 Loading media on the F1612 with vacuum selector

Loading media means positioning the media on the table and setting the origin and media size (working area). Sometimes this is a two-step process (first loading the media, then setting the media size). Sometimes it can be done in one step (setting the size, then loading), depending on the type and size of the media.

1.4.2.1 Loading sheet media



WARNING: For safety reasons, always use this procedure to load media. Only if this method is used, is it sure that the machine will not make unexpected movements and harm the operator.

1. Make sure the machine is activated and Axis Control is running (see section 3.1).
2. The program Axis Control normally starts up in the media menu. In this menu the working area can be set. Setting the working area is only part of the loading procedure.



3. Click  to initiate the loading sequence.

The main window changes to the load window. On the left there is the choice between loading a roll and loading a sheet.

4. Click the radio button in front of “Sheet”.

The options for loading sheet material are shown.

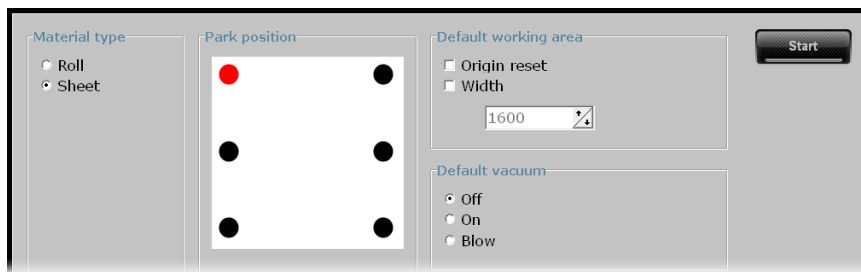





FIG 1-10
OPTIONS FOR LOADING SHEET MATERIAL

- The park position is the position the carriage with modules and tools will go to when the loading sequence is started. Click on a circle to set the park position. The red circle is the current selected park position. The park position depends on whether the media has to be loaded from the front or from the rear.
- With the default working area the origin and sheet width can be set. If the box in front of “Origin reset” is checked, the origin is reset to the mechanical origin. Otherwise the origin stays the same. If the box in front of “Width” is set, the width of the media that will be loaded can be set.
- The initial state of the vacuum pump can also be set before the loading sequence is started. If needed, the vacuum pump can be controlled with the remote during loading itself (see section 3.2.5).

- Choose the setting and click the  button.

The machine adjusts the vacuum selector if a new width is chosen, moves the carriage to the park position and sets the vacuum as chosen.

- Go to the machine and load the sheet. Make sure to activate the vacuum at least once (use  on the remote to control the vacuum) to check if the media is lying flat enough. If the media is loaded correctly, click .

The carriage returns to the origin and Axis Control goes to the media menu. The origin and media width (size) can be changed, if needed (see section 1.4.1.3).

1.4.2.2 Loading roll media

The conveyor belt in combination with the pneumatic pack and the roll support are recommended for roll material. Loading is then very easy with following procedure.



WARNING: For safety reasons, always use this procedure to load media. Only if this method is used, is it sure that the machine will not make unexpected movements and harm the operator.

- Make sure the machine is activated and Axis Control is running (see section 3.1).
- The program Axis Control normally starts up in the media menu. In this menu the working area can be set. Setting the working area is only part of the loading procedure.



- Click  to initiate the loading sequence.

The main window changes to the load window. On the left you can choose between loading a roll and loading a sheet.

- Click the radio button in front of "Roll".

The options for loading roll material are shown.

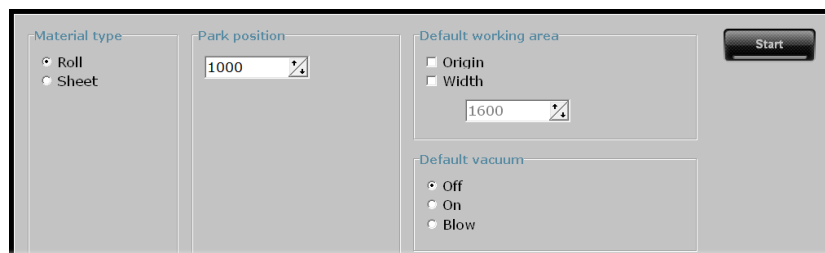



FIG 1-11
OPTIONS FOR LOADING ROLL MATERIAL

- The park position is the position the carriage with modules and tools will go to when the loading sequence is started. Recommended values are 850mm-1000mm, depending on the size and weight of the media. The media can be guided on the table until it is situated just under the media advance clamps. Heavier media has to be pushed a bit further on the table.

- With the default working area the origin and sheet width can be set. If the box before the origin is checked, the origin is reset to the mechanical origin. Otherwise the origin stays the same. If the box before the width is set, the width of the media that will be loaded can be set.
- The initial state of the vacuum pump can also be set before the loading sequence is started. If needed, the vacuum pump can be controlled with the remote during loading itself (see section 3.2.5).

5. Choose the setting and click the  button.

The machine adjusts the vacuum selector if a new width is chosen, moves the carriage to the park position and sets the vacuum as chosen.

6. Insert a media core holder in each end of the media roll. Loosen the core holders with the black knob on the side. Figure 1-9 shows a loosened ❶ core holder and an expanded ❷ core holder.

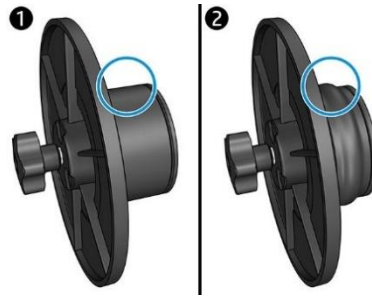





FIG 1-12
MEDIA CORE HOLDER

7. Insert the loosened core holders into each end of the roll. Tighten each end with the black knob, making sure both core holders are secured.
8. Place the media roll on the media supply rollers from the back of the machine. Place the flange-equipped roll on the media supply rollers. Set the flanges inside the groove of the flange guide. The flange guides can be moved laterally on the roller.
9. First set the media advance clamps this way they divide the media into equal parts with the two outer clamps at about 10 cm from the side. Slide the media until the front end is situated under the media advance clamps. Use the remote () to control the vacuum and to hold the media down. The media advance clamps can be controlled with the up and down keys of the remote ( or ). Try and put the media as parallel as possible to the side.



WARNING: Make sure that the compressed air hoses are not jammed by putting the clamps too close to the side or to each other.

10. Click .





The media is moved forward as far as possible (the X origin as far as possible forwards. The carriage returns to the right; the media length is set to its maximum and Axis Control goes to the media menu. The origin and media width (size) can be changed if needed (see section 1.4.1.3.).

1.4.2.3 Setting origin and media size

After loading the media, Axis Control goes to the media menu where the origin and size of the loaded media can be changed, if necessary.

- To change the origin, click the **Origin** button. The origin position can be changed by either filling in a value or moving the carriage with the arrow keys.

- To change the origin by filling in the values, change the values under origin (X) and origin (Y), then click the **Update** button. The carriage then moves to the new origin. Change the values, if necessary.

- Click , ,  and  to change the origin with the keyboard or use the  keys on the remote. The carriage will move accordingly. The red light on the carriage makes the origin visible on the table itself. Click **Camera**. The camera is moved over the origin so the origin can be seen on screen. If **Pointer** is clicked, the pointer (red light) is set again over the origin.

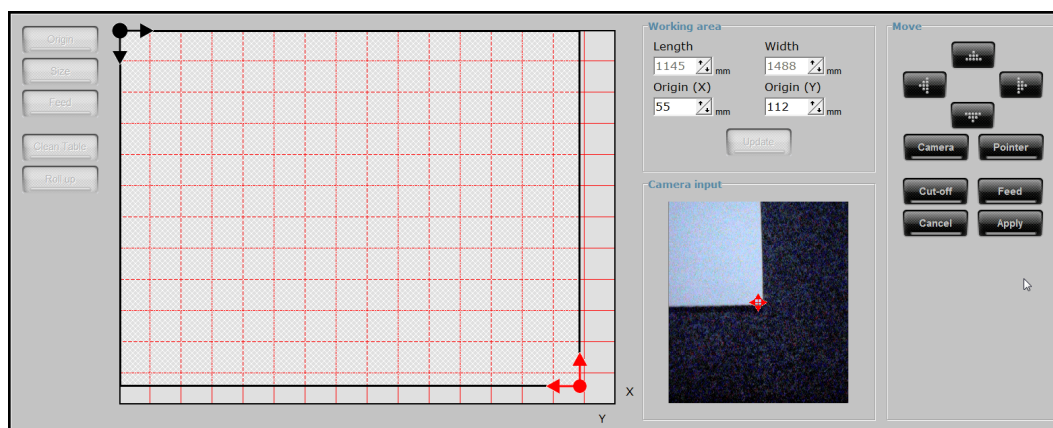
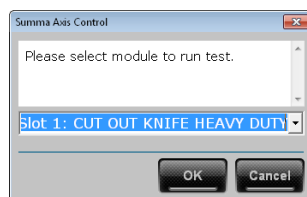

FIG 1-13
OPTIONS FOR SETTING THE ORIGIN

- There are three different ways to confirm the new origin.





- Click **Apply** to confirm the chosen origin.
- Click **Feed** to move the chosen origin forward as far as possible to the front (mechanical origin X value \rightarrow 0).
- Click **Cut-off** to cut off the media at the chosen origin. If more than one tool is available to cut off the media, the program lets the user choose the tool.



- Or click **Cancel** to leave the origin unchanged.

4. To change the size (width and length), click the **Size** button. The width and length of the loaded media can be changed by either filling in a value or moving the carriage with the arrow keys.

- To change the size by filling in the values, change the values under length and width and click the **Update** button. The carriage then moves to the new size. Change values, if necessary.

- Click , ,  and  to change the size with the keyboard or use the  keys on the remote. The carriage will move accordingly. The red light on the carriage makes the maximum x and y position visible on the table itself. Click **Camera**. The camera is moved over the maximum x and y position, so the size can be seen on the screen. If **Pointer** is clicked, the pointer (red light) is set again over the maximum x and y position.



NOTE: Try and define the size in the y direction as close as possible to the edge of the loaded media. This is necessary in order to create an optimal vacuum.

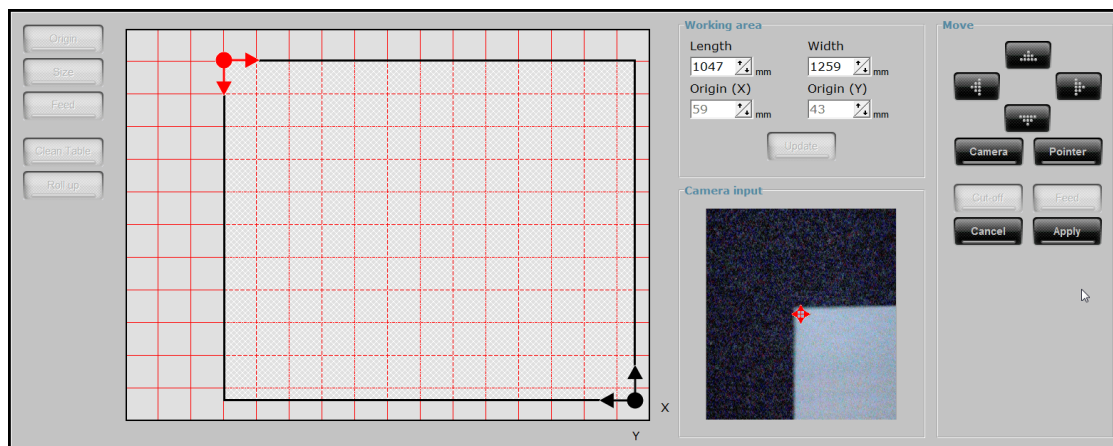

FIG 1-14
OPTIONS FOR SETTING THE SIZE

5. Click **Apply** to confirm the chosen size or click **Cancel** to leave the size unchanged.

If a new media size is set, the vacuum selector will move to its new position. Subsequently the carriage will go back to the origin.



NOTE: There is also a quick way to change the origin and media size with the remote only. However, in this case the options are limited. This is explained in section 3.2.3.

1.4.3 Loading media on larger tables

1.4.3.1 Loading sheet media



WARNING: For safety reasons, always use this procedure to load media. Only if this method is used, is it sure that the machine will not make unexpected movements and harm the operator.

1. Make sure the machine is activated and Axis Control is running (see section 3.1).
2. The program Axis Control normally starts up in the media menu. In this menu the working area can be set. Setting the working area is only part of the loading procedure.



3. Click  to initiate the loading sequence.

The main window changes to the load window. On the left there is the choice between loading a roll and loading a sheet.

4. Click the radio button in front of "Sheet".

The options for loading sheet material are shown.

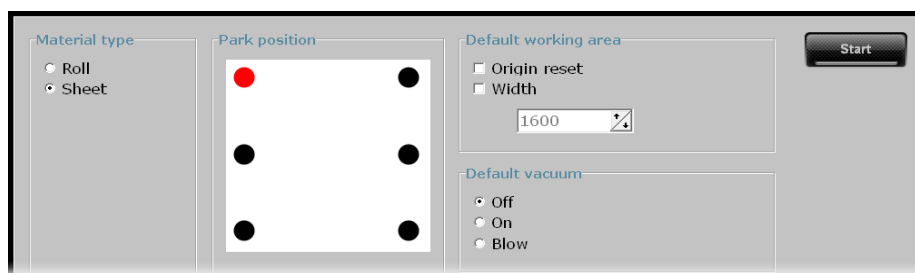





FIG 1-15
OPTIONS FOR LOADING SHEET MATERIAL

- The park position is the position the carriage with modules and tools will go to when the loading sequence is started. Click a circle to set the park position. The red circle is the current selected park position. The park position depends on whether the media has to be loaded from the front or from the rear.
 - With the default working area the origin and sheet width can be set. If the box in front of "Origin reset" is checked, the origin is reset to the mechanical origin. Otherwise the origin stays the same. If the box in front of "Width" is set, the width of the media that will be loaded can be set.
 - The initial state of the vacuum pump(s) can also be set before the loading sequence is started. If needed, the vacuum pump(s) can be controlled with the remote during loading itself (see section 3.2.5).
5. Choose the setting and click the  button.

The machine switches the correct vacuum zones on or off, moves the carriage to the park position and sets the vacuum as chosen.

6. Go to the machine and load the sheet. Make sure to activate the vacuum at least once (use  on the remote to control the vacuum) to check if the media is lying flat enough. If the media is loaded correctly, click .

The carriage returns to the origin and axis control goes to the media menu. The origin and media width (size) can be changed, if needed (see section 1.4.3.3 Setting origin and media size).

1.4.3.2 Loading roll media

The conveyor belt in combination with the media clamps pack and the roll support are recommended for roll material. Loading is then very easy with following procedure.



WARNING: For safety reasons, always use this procedure to load media. Only if this method is used, is it sure that the machine will not make unexpected movements and harm the operator.

1. Make sure the machine is activated and Axis Control is running.
2. The program Axis Control normally starts up in the media menu. In this menu the working area can be set. Setting the working area is only part of the loading procedure.



3. Click  to initiate the loading sequence.

The main window changes to the load window. On the left you can choose between loading a roll and loading a sheet.

4. Click the radio button in front of "Roll".

The options for loading Roll material are shown.

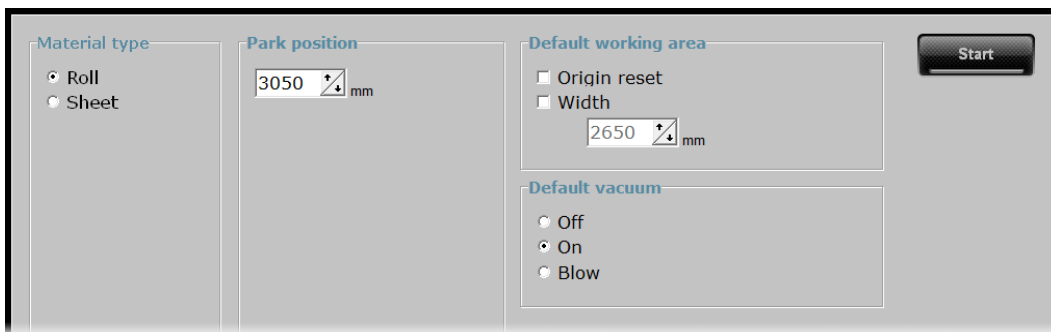



FIG 1-16
OPTIONS FOR LOADING ROLL MATERIAL

- The park position is the position the carriage with modules and tools will go to when the loading sequence is started. Recommended values are 0 to 200 less than the maximum cutting length, depending on the size and weight of the media. The media can be guided on the table until it is situated just under the media advance clamps. Heavier media has to be pushed a bit further on the table.
- With the default working area the origin and sheet width can be set. If the box before the origin is checked, the origin is reset to the mechanical origin. Otherwise the origin

stays the same. If the box before the width is set, the width of the media that will be loaded can be set.

- The initial state of the vacuum pump can also be set before the loading sequence is started. If needed, the vacuum pump can be controlled with the remote during loading itself (see section 3.2.5).

5. Choose the setting and click the  button.

The machine switches the correct vacuum zones on or off, moves the carriage to the park position and sets the vacuum as chosen.

6. Insert a media core holder in each end of the media roll. Loosen the core holders with the black knob on the side. Figure 1-14 shows a loosened ① core holder and an expanded ② core holder.

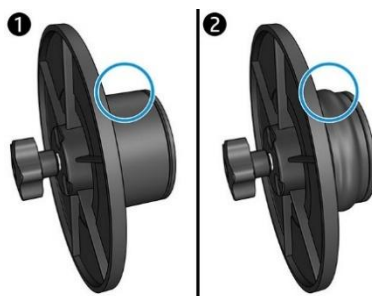





FIG 1-17
MEDIA CORE HOLDER

7. Insert the loosened core holders into each end of the roll. Tighten each end with the black knob, making sure both core holders are secured.
8. From the back of the machine, place the media roll on the media supply rollers. Place the flange-equipped roll on the media supply rollers. Set the flanges inside the groove of the flange guide. The flange guides can be moved laterally on the roller.
9. First set the media advance clamps this way they divide the media into equal parts with the two outer clamps at about 10 cm from the side. Leave around 50 cm space between each clamp. Disable the clamps, which are not being used, if the media doesn't cover the full width. Slide the media until the front end is situated under the media advance clamps. Use the remote () to control the vacuum and to hold the media down. The media advance clamps can be controlled with the up and down keys of the remote ( or ). Try and put the media as parallel as possible to the side.







WARNING: Make sure that the compressed air hoses are not jammed by putting the clamps too close to the side or each other.

10. Click .

The media is moved forward as far as possible (the X origin as far as possible forwards. The carriage returns to the right, the media length is set to its maximum and Axis Control goes to the media menu. The origin and media width (size) can be changed if needed (see section 1.4.3.3 Setting origin and media size).

1.4.3.3 Setting origin and media size

After loading the media, Axis Control goes to the media menu where the origin and size of the loaded media can be changed, if necessary.

11. To change the origin, click the **Origin** button. The origin position can be changed by either filling in a value or moving the carriage with the arrow keys.
 - To change the origin by filling in the values, change the values under origin (X) and origin (Y), then click the **Update** button. The carriage then moves to the new origin. Change the values, if necessary.
 - Click , ,  and  to change the origin with the keyboard or use the  keys on the remote. The carriage will move accordingly. The red light on the carriage makes the origin visible on the table itself. Click **Camera**. The camera is moved over the origin so the origin can be seen on screen. If **Pointer** is clicked, the pointer (red light) is set again over the origin.

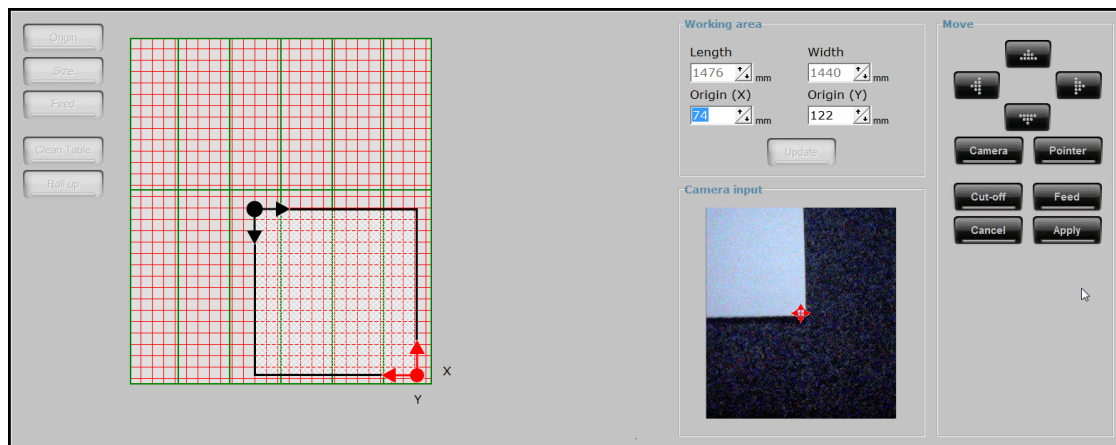
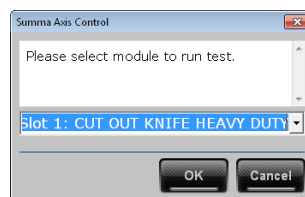

FIG 1-18
OPTIONS FOR SETTING THE ORIGIN





12. There are three different ways to confirm the new origin.
 - Click **Apply** to confirm the chosen origin.
 - Click **Feed** to move the chosen origin forward as far as possible to the front (mechanical origin X value \rightarrow 0).
 - Click **Cut-off** to cut off the media at the chosen origin. If more than one tool is available to cut off the media, the program lets the user choose the tool.



13. Or click **Cancel** to leave the origin unchanged.

14. To change the size (width and length), click the **Size** button. The width and length of the loaded media can be changed by either filling in a value or moving the carriage with the arrow keys.

- To change the size by filling in the values, change the values under length and width and click the **Update** button. The carriage then moves to the new size. Change values, if necessary.

- Click , ,  and  to change the size with the keyboard or use the  keys on the remote. The carriage will move accordingly. The red light on the carriage makes the maximum x and y position visible on the table itself. Click **Camera**. The camera is moved over the maximum x and y position, so the size can be seen on the screen. If **Pointer** is clicked, the pointer (red light) is set again over the maximum x and y position.



NOTE: Try and define the size in the y direction to the right side of a green line. If necessary, move the media a little bit. Those lines show the vacuum zones. This is necessary to create an optimal vacuum.

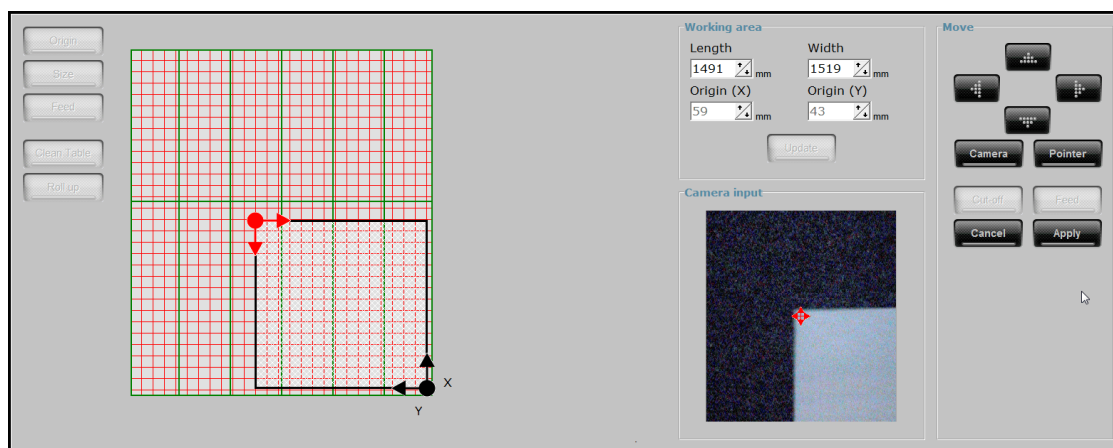

FIG 1-19
OPTIONS FOR SETTING THE SIZE

15. Click **Apply** to confirm the chosen size or click **Cancel** to leave the size unchanged.

If a new media size is set, the vacuum zones, covered by the media, will be switched on; the others will be switched off. Subsequently the carriage will go back to the origin.



NOTE: There is also a quick way to change the origin and media size with the remote only. However, in this case the options are limited. This is explained in section 3.2.3.

1.5 Tools



ATTENTION: This section explains the different types of tools and how to remove/install the knives from/in those tools. After installation of the tool in the module, a calibration is mandatory. That is explained in section 2.



NOTE: The result of the calibration of the tools (tool parameters) is stored on the mainboard of the table. The reference that is used is the slot position on the carriage. This means that calibration has to be redone each time the position of the tool is changed or each time the tool is used in another module.

1.5.1 Drag knife holder for the drag head module

1.5.1.1 Removing the knife from the drag knife holder

1. Turn the knurled adjustment knob (3) clockwise to push the knife (1) out of the holder (2).



FIG 1-20

REMOVING THE KNIFE FROM THE STANDARD DRAG KNIFE HOLDER

2. Carefully pull the knife from the holder.

1.5.1.2 Installing the drag knife into the drag knife holder

1. Remove the aluminum part from the plastic knife holder (2) by turning the knurled adjustment knob (3) counterclockwise until the aluminum part comes out of the holder.
2. Insert the conical, non-cutting end of the knife into the opening in the narrow end of the holder. Gently push the knife all the way in.
3. Turn the holder upside down and tap it lightly on a solid surface to ensure that the knife is completely inserted.
4. Slowly turn the knurled knob clockwise until the tip of the blade extends the distance required for the desired cutting media (t), as shown in the figure below.

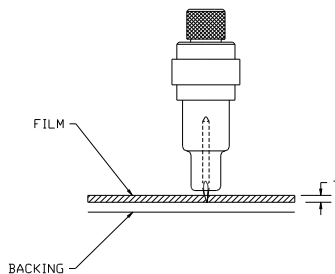

FIG 1-21

KNIFE LENGTH ADJUSTMENT

5. Insert the knife holder into the head clamp, seating it firmly.

1.5.2 Kiss Cutting Tool for the tangential module

1.5.2.1 Kiss Cutting Tool

The Kiss Cutting Tool is able to kiss cut the most demanding roll materials. The applied force can be up to 2000 gr. There are 3 pressure adjustment screws, so the applied cutting pressure can be manually adjusted accurately.



FIG 1-22
KISS CUTTING TOOL

1.5.2.2 Removing a knife from the Kiss Cutting Tool

A knife has been pre-installed in the Kiss Cutting Tool. For safety reasons, the knife depth has been set to zero. Simply turn out the knife to start.



FIG 1-23
KNIFE HOLDER KISS CUTTING TOOL

Turn the knife holder counterclockwise. The holder will rise up, eventually making it possible to lift the knife holder out of the tool.

The knife can be removed from the knife holder by using something like a flat screwdriver to pry between the knife and the knife holder in the groove.

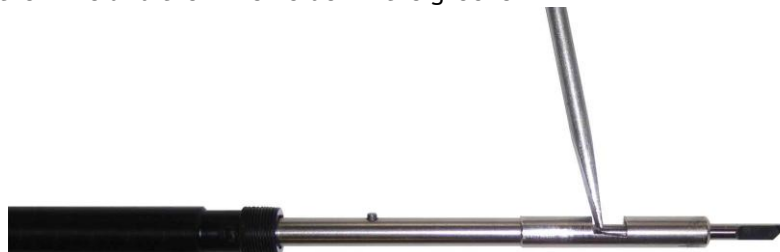

FIG 1-24
REMOVAL OF THE KISS CUTTING KNIFE

1.5.2.3 Installing a knife from the Kiss Cutting Tool

1. Insert the standard knife blade into the knife holder. Make sure the knife blade is firmly fixed in the holder. The knife is inserted correctly if it cannot be removed manually from the knife holder. The installation tool can be used to apply enough pressure on the knife to secure it.



FIG 1-25
BLADE ASSEMBLY KISS CUTTING TOOL

2. Gently insert the knife holder into the tool shaft. Hold the nose piece in place with one hand and, with the other hand, turn the knife holder counterclockwise until the alignment pin fits into the small notch of the tool shaft. Now, turn the knife holder clockwise until its thread takes hold inside the tool shaft.
3. Hold the nose piece in place with one hand. Adjust the knife depth with the other hand by turning the knife holder clockwise until the knife tip is just visible from under the nose piece.

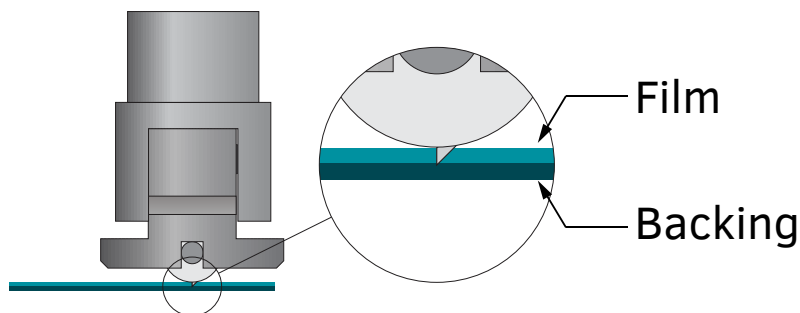

FIG 1-26
KNIFE DEPTH ADJUSTMENT KISS CUTTING TOOL



NOTE: For most vinyl cutting operations, the knife blade tip will be barely visible at the bottom of the knife tool. If the knife blade tip is clearly visible, the knife depth must be readjusted.



ATTENTION: To benefit fully from the advantages of the tangential knife, the amount the knife extends is very important. The knife pressure should not control the knife depth. The two rollers of the nose piece should always touch the media, thus controlling the knife depth.

1.5.3 Cutout Tool for tangential module

1.5.3.1 Types of cutout tools

The Cutout Tool serves for cutting completely through the material. There are three different cutout tools, each of which used for specific applications.

The Single Edge Cutout Tool is designed for detailed cutting (e.g. on vinyl, thin cardboard ...). The Double Edge Cutout Tool ensures minimal wear when cutting tough materials (e.g. magnetic, textile ...) and the Heavy Duty Cutout Tool is suitable for thicker materials (e.g. softboard, carpet,...).



FIG 1-27
SINGLE EDGE CUTOUT TOOL



FIG 1-28
DOUBLE EDGE CUTOUT TOOL



FIG 1-29
HEAVY DUTY CUTOUT TOOL

1.5.3.2 Removing a knife from the Cutout Tool

The knife is clamped with a metal piece that is fixed with two screws.

The single edge and the double edge knife also have a gliding disk for protection.

To remove the knife from the holder, loosen the two screws a turn or two.

Then carefully take out the knife. The gliding disk of the single edge and double edge knife will have to be pushed backwards before the knife can be reached.

1.5.3.3 Installing a knife in the Cutout Tool

In order to install a knife, check at first if the metal piece, that clamps the knife, is loose. If not, loosen it by turning the two screws. Then turn the tool this way the plate faces down. Take the knife with the tool and gently slide it into the tool.

Hold the tool upside down and check if the knife is completely pushed down. Then secure the knife with the two screws.

1.5.4 Electronic Oscillating Tool (EOT) for the tangential module

1.5.4.1 EOT

The tool fits into the tangential module and needs to be connected with a cable to the camera unit. The cable is slotted and marked with a triangle (see detail figure). Orientate the cable this way so this triangle faces the top before connecting the cable. The Oscillating Tool is driven by an electric motor, producing up to 12.000 rpm and it has a stroke of +/-1mm. Knives are available to cut material up to a thickness of 24 mm. The EOT is used for cutting foam boards, corrugated cardboard and other soft thick materials.



FIG 1-30
ELECTRONIC OSCILLATING TOOL

1.5.4.2 Removing a knife from the EOT

The knife is clamped with a screw. Relatively short knives also have a gliding disk for protection. To remove the knife from the holder, first remove the gliding disk. Then completely remove the setscrew that holds the knife. This to make sure that the setscrew is not fastened by mistake without a knife in the EOT because this could seriously damage the knife holder shaft. Then carefully take out the knife.

1.5.4.3 Installing a knife in the EOT

Check if the gliding disk is removed and if the setscrew, that clamps the knife, is completely removed. If not, do so. The picture below shows when the gliding disk is removed. The setscrew is also removed and the knife holder shaft is slightly sticking out at the left side.



FIG 1-31
KNIFE HOLDER SHAFT – SETSCREW REMOVED FROM EOT

Take the knife and gently slide it in the tool.

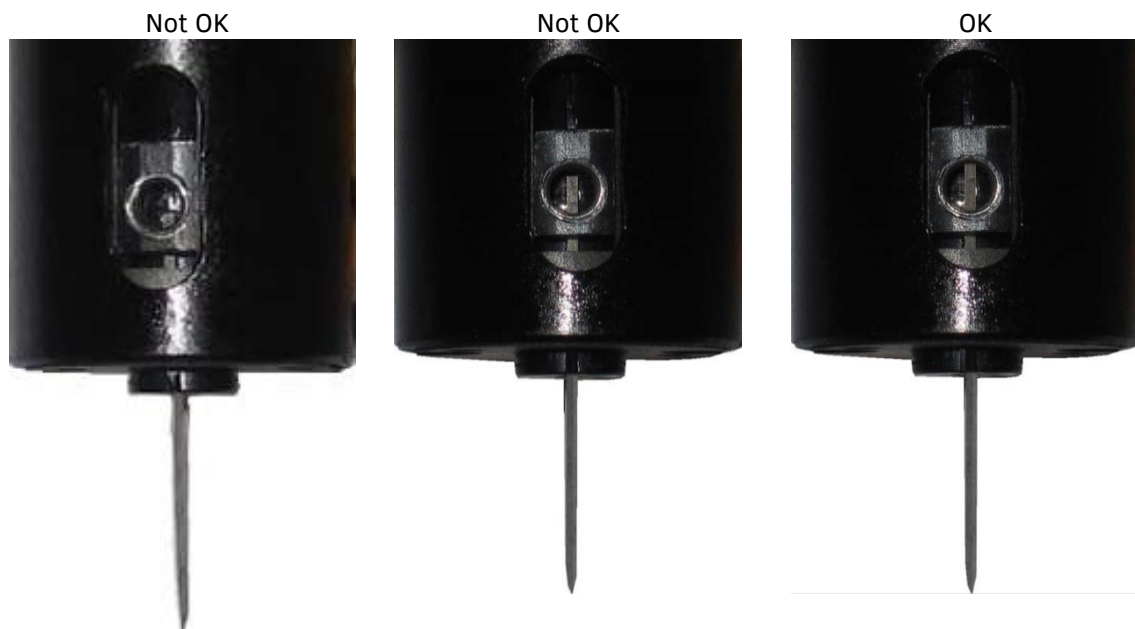

FIG 1-32
KNIFE IN EOT

Look in the threaded hole and check if the knife is completely pushed down. Then secure the knife with the setscrew.



ATTENTION: Fasten the setscrew carefully. Make sure it fastens the knife. Only if the knife is inserted deeply enough, secure the setscrew.

If the setscrew is fastened without a knife, then the knife holder will be damaged and it will be impossible to put in a knife correctly. Never fasten the setscrew when no knife is inserted. It is advised to replace the setscrew from time to time.

1.5.5 Creasing tools for the tangential module



FIG 1-33
CREASING TOOLS

The creasing tools are available in different sizes and shapes to easily create folds into cardstock, cardboard, corrugated cardboard and plastics for boxes or displays. Basically, creasing wheels with a pronounced rim are ideal for the processing of 'filled material'. The ones with the more rounded shapes are ideal for the processing of materials, which have corrugated or honeycombed centres.

1.5.6 Corrugated tool for the tangential module

1.5.6.1 Corrugated tool

The Corrugated Tool is ideal for cutting packaging materials. Its patented wheels provide a smooth, die-cut-like finish by pressing down the material, ensuring precision cuts with a high-quality finish.



FIG 1-34
CORRUGATED TOOL

1.5.6.2 Removing a knife from the corrugated tool

Remove first the wheels by sliding it from the tool. Then loosen the setscrew holding the knife.

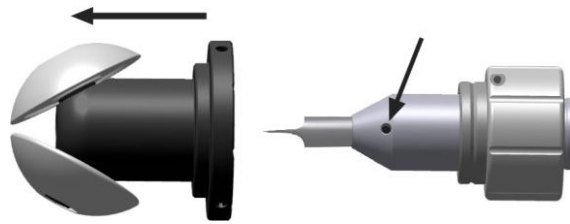

FIG 1-35
REMOVING THE KNIFE FROM THE CORRUGATED TOOL

1.5.6.3 Installing a knife in the corrugated tool

Align the knife so that the flat part of the round shank faces the setscrew. Push the knife completely in the holder and secure with the setscrew. Afterwards put the wheels back on.

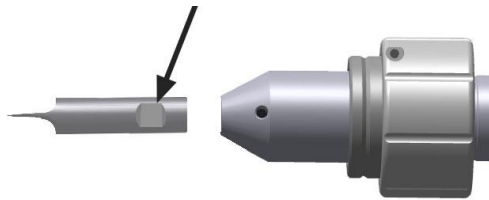

FIG 1-36
INSTALLING THE KNIFE FROM THE CORRUGATED TOOL

1.5.7 V-Cut tools for the tangential module

1.5.7.1 Types of V-Cut tools

The V-Cut tools are basically static knives that are placed under an angle. By cutting in two directions, V-groves will be cut out. This makes it possible to bend/fold thicker materials. This tool is particularly well suited for honeycomb boards, soft foam boards, sandwich boards and corrugated cardboards. Depending on the folding angle, different V-shapes are required. There are different angles.



FIG 1-37
V-CUT TOOLS

1.5.7.2 Installing knives in the V-Cut tools

There is a special fixture delivered with the V-Cut tools to be able to change the knives quickly. If this fixture is used for installing the knife, fewer calibrations need to be done when the knife is changed. First remove the knife clamp. Put the fixture on the tool. Put the knife in its place (make sure the knife tip just touches the fixture). Put the knife clamp back and secure the two screws firmly.

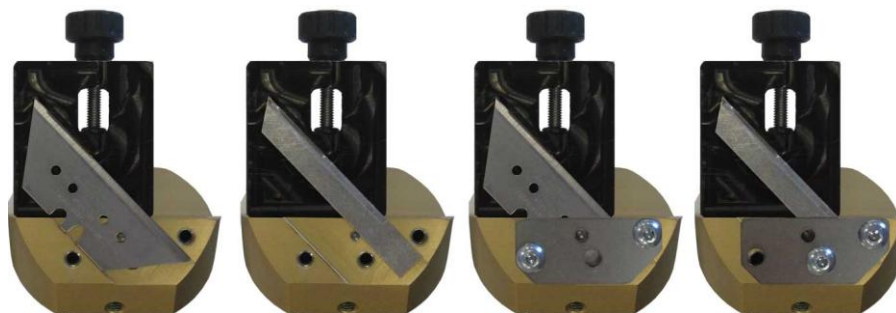

FIG 1-38
INSTALLING KNIVES IN THE V-CUT TOOLS

1.5.7.1 Bevel Cut tool

The knives of the V cut tools are relative long (to be able to cut thick materials) . Sometimes a thinner material needs a knife that is more rigid for some applications. For this there is the Bevel cut knife which has a shorter knife, it is only available in 45 degrees. The usage of this knife is analogue to the use of the normal 45-degree V-cut knife.



FIG 1-39
BEVEL CUT TOOL

1.5.8 Perforating Tool

The perforating tool is used to make perforations in a very efficient and fast way. By using this tool, the perforated materials will be a lot easier to bend or fold. Then, the folds will have sharper 90° edges resulting in a nicer finish. This will save considerable time in the assembling of, for instance, cardboard or polypropylene boxes.



FIG 1-40
PERFORATING TOOL

There are 4 different rotary perforating knives available. Two finer one used mainly for cardboard and polypropylene. And two used for corrugated cardboard.

Cardboard/Polypropylene

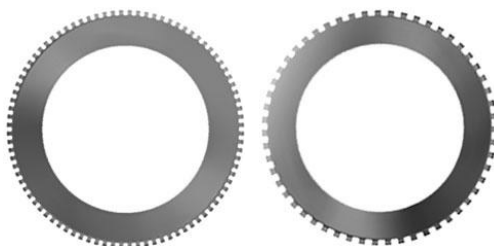

Corrugated cardboard

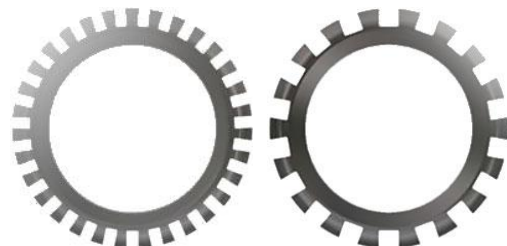

NOTE: It is not recommended to use the perforating tool on a machine without an ADC.

1.5.9 Pneumatic Oscillating Tool

1.5.9.1 General

The Pneumatic Oscillating Tool, powered by compressed air, moves the knife up and down with a stroke of maximum 8 mm and a frequency of maximum 150Hz. The robust construction of the tool makes it suitable to cut thick and or tough boards like honeycomb board, corrugated cardboard and foam boards. Also some soft foams and rubbers can be cut with adjusted speeds. The POT fits into the tangential module. Use the adaptor with the two tubes for connection to the central camera unit of the F1612. Use the adaptor with the single thicker tube for connecting to the left side of the carriage of the larger tables. Use the connection marked with L or POT. The tool can be placed in any of the three slots but only one POT can be installed at once.



FIG 1-41
POT

1: pneumatic oscillator; 2: pneumatic connections; 3: knife; 4: gliding disk (not for POT-L)

1.5.9.2 Types of Pneumatic Oscillating Tool

Currently there are two types available. The standard POT and the POT-L. The standard POT has a gliding disk and can cut materials up to 25 mm thick. The POT-L has no gliding disk and can cut materials from 20 mm to 42 mm thick.



FIG 1-42
TYPES OF PNEUMATIC OSCILLATING TOOLS

1.5.9.3 Replacing a knife in the POT

Remove the gliding disk. Locate the setscrew that holds the knife. Unscrew it. Take the knife and gently take it out. Take the new knife and slide it in the tool.



FIG 1-43
KNIFE POT

Check if the knife is completely pushed down. Then secure the knife with the setscrew.



ATTENTION: Fasten the setscrew carefully. Make sure it fastens the knife. Only if the knife is inserted deeply enough, secure the setscrew.

If the setscrew is fastened without a knife, the knife holder will be damaged, and it will be impossible to put in a knife correctly. Never fasten the setscrew when no knife is inserted. It is advised to replace the setscrew from time to time.

The gliding disk can only be put on the tool when the tool is mounted in the tangential module. The gliding disk is keyed, so it clicks in its position.

2 SETTING UP MODULES / TOOLS

2.1 Introduction

2.1.1 General remarks on the calibration of the tools

There are four kinds of modules: the drag module, the tangential module, the miller module and the rotary module. The tangential module automatically recognizes which tool is mounted. The router module is specially made for the miller only. The rotary module has no tools; the knife is mounted in the module itself. The drag module cannot automatically recognize whether a pen or drag knife is mounted. The user will have to define this while setting the pen/knife parameters.

There are two sets of parameters for the tools/knives.

The first set of parameters is more related to the module and the up and down position.

Down position	Maximum down position the knife/tool can reach, is usually the position at which the job is cut.
Up Position	Height of the knife/tool when it is moving but not cutting during a job.
Velocity	Speed used for running the internal test of Axis Control.
Lift –up velocity	Speed at which the module raises.
Lowering velocity	Speed at which the module goes down.
Flute direction	Special parameter only used for creasing wheels in combination with corrugated cardboard.
Down position offset	Special parameter only used for creasing wheels in combination with corrugated cardboard.
Down delay	Special parameter for the Router module. The amount of time the router waits before it starts routing after it reaches the down position.

The second set of parameters is more related to the knife/tool itself (a routing bit has no second set of parameters).

Origin	Correction factor for the direction in which the knife cuts. Wrong setting results in an irregular bend in the start of a cutting line.
Lateral	Correction factor for the offset for the knife along the cutting path. Wrong setting results in misalignment of cutting lines in the opposite direction.
Longitudinal	Correction factor for the start point of the cutting line. Wrong setting results in unclosed corners or unwanted overcut.
Blade compensation	Correction factor for cutting materials. Wrong settings result in bad small curves.
Frequency RM	Speed at which the rotary knives rotates.
Frequency EOT	Speed at which the Electric oscillating tool goes up and down.

The flatbed has no control panel or screen. Everything is done with the program Axis Control. Sometimes in combination with the remote control. The remote connects to the computer with Bluetooth. Please refer to section 1.3.6 for software installation for setting up the remote.

Speed settings need to be set by hand in Axis Control. The velocity setting is only used for internal tests. The speed at which a job is processed is set in Summa Go Produce



NOTE: When calibrating a tool/module, use the same speed than the one that will be used later. Speed settings can influence certain parameters.

Certain calibrations will need to be done after installing a tool. Those parameters have a double function. Setting them correctly makes sure that the cutting quality is optimized and also makes sure that the print and cut jobs are more precise.

These calibrations can be done automatically (with ADC – see section 2.4) or manually (see section 2.5)



NOTE: It is absolutely recommended to label the modules. Also, always put them in the same position on the carriage. The tool parameters are automatically saved when a tool is used. However, tool parameters are also partly module dependent. If the same module is always mounted at the same place, the tool parameter dependency of the module will be nullified.

If a tool is calibrated at a certain place with a certain module, those parameters are saved in



the machine the moment this tool is used for a job or if  is clicked. If the tool is remounted in the module at a later stage, the machine automatically sets the tool parameters to the previous values.

2.1.2 Automatic Depth Control

The Automated Depth Control (ADC) simplifies tool, knife or bit calibrations significantly. The ADC measures the tip of the knife or bit accurately and sets the down position of the tool to the level of the table (see section 2.4).

Also other knife settings can be measured (tangential parameters) with the ADC. This ensures the best settings can always be used to get the most optimal cut quality.

The ADC has a sensor unit in the right-hand side_cover to measure the tools in slot 2 & 3 (the two slots to the right side of the camera module). A second sensor unit in the left-hand side can measure the tools in slot 1.



FIG 2-1
ADC RIGHT SIDE

When starting up the table or after a tool change, the down position of each installed knife is measured to detect changes and avoid operator errors if the ADC is installed.



NOTE: Section 2.5 explains how to manually calibrate the tools, this can be used to make small adjustments to the automatic calibration should it be necessary (e.g. depth is sometimes media dependent).

Only the drag knife cannot be calibrated with the ADC, the rest of the tools/knives/bits can be calibrated with the ADC.

2.1.3 Tools in the accessory box

In the accessory box, delivered with the cutting table, there are some tools for installing the modules/tools on the flatbed cutter. Other tools may be delivered together with certain tools or options.

Hex screwdriver 4 mm: this is used for loosening the screw that holds the module on the carriage. It can also be used for lifting the module when it is removed.



FIG 2-2
HEX SCREWDRIVER 4 MM

Hex screwdriver 2.5 mm: this is used for removing the gliding disk (on both Cutout Tool and Electronic Oscillating Knife) and for changing knives on the cutout tool holders.



FIG 2-3
HEX SCREWDRIVER 2.5 MM

Wrench #10 mm: This wrench is used to loosen the nut of the rotary module (optional) in order to replace the rotary knives. This wrench is delivered together with the rotary module option.



FIG 2-4
WRENCH #10 MM

Tool wrench: this tool can be used when the tool has been tightened too much in the module. It is not recommended to use this tool to mount other than oscillating tools in the module.



FIG 2-5
TOOL WRENCH



ATTENTION: If the wrench is used to mount the oscillating tools in the module, do not tighten more than $\frac{1}{4}$ of a turn 'hand tight' without the wrench.



ATTENTION: Always use the tool this way the direction in which is turned, is according to the arrow. Otherwise the nut on the tool will be irreversibly damaged.



Hex key 1.5 mm: This key is used to replace the knives on an EOT. Each knife for the EOT is delivered with such a hex key.



FIG 2-6
HEX KEY 1.5 MM

Hex key 2 mm: This key is used to replace the knives on a POT. Each knife for the POT is delivered with such a hex key.



FIG 2-7
HEX KEY 2 MM

2.2 Installing / Removing a module



WARNING: For safety reasons, always make sure no tool is installed in the module. Only install a module when the flatbed is switched off or after clicking 'Change Tool' in Axis Control.



FIG 2-8
INSTALLING/REMOVING A MODULE

2.2.1.1 Installing a module

In order to install a module, line up the 5 highlighted areas and slide the module down. The module glides into the carriage in a dovetail guiding. Do not use excessive force, otherwise the connector can be damaged. Recheck the alignment when in doubt. The module must be pushed down approximately 15 mm (0,6") and is secured with one screw at the right side. Before securing the module check if the connector of the module is completely seated in the connector of the carriage.



FIG 2-9
INSTALLING/REMOVING A MODULE

2.2.1.2 Removing a module

To remove a module, loosen the screw at the right side of the module for about 1 turn counterclockwise with the hex screwdriver. Put this screwdriver in the hole under the module at the right side. Now gently lift the module with the screwdriver 3 to 4 mm (0.12 to 0.16"). Guide the module manually for an extra 10 mm (0.4") and remove it from the carriage. The drag module does not have such a hole to lift the module, so just lift it manually.



NOTE: It is recommended to remove any unused modules. Leaving unused modules on the carriage can lead to poorer cutting quality.

2.2.1.3 Rotary module

Position 2 and 3 on the carriage need to be free before the rotary module can be installed. The module has to be installed in position 3, but occupies position 2 and 3. Position 1 can still be used should an additional tool be necessary. The rotary module needs to be connected with an electric cable for driving the motor and a pneumatic hose for cleaning the knife. The electric cable has a slotted connector that is marked with a triangle (see detail figure). Orientate the cable this way the triangle faces the top before connecting the cable. Make sure the hose with the correct pneumatic connection is attached to the rotary module (see figure 2-10 and 2-11 below) and connect the other end to the carriage. On the larger tables use the connection marked RM or R for the pneumatic connection.



FIG 2-10
ELECTRIC CONNECTOR



FIG 2-11
CONNECTOR FOR LARGER
TABLES



FIG 2-12
CONNECTOR FOR F1612

2.2.1.4 Router module

Position 2 and 3 on the carriage need to be free before a miller module can be installed. The module has to be installed in position 3, but occupies position 2 and 3. Position 1 can still be used should an additional tool be necessary. The pole, which leads the tube that runs to the vacuum cleaner, holds a plate with a dovetail guiding similar to the guiding on the carriage. This can be used to store the miller module when it is not in use. There is no screw available to secure the miller module.

2.3 Installing Tools and knives.

2.3.1 Installing Kiss Cutting Tool

1. In the Axis Control window click . If the tangential module is not mounted on the flatbed yet, install it as explained in section 2.2.
2. Check if the correct adjust screw is mounted (there are three ranges: up to 120 gram; up to 650 gram and up to 2000 gram). Mount the Kiss Cutting Tool in the tangential module. Align the pin in the slot as shown in the figure below and hold the internal shaft of the tangential module in its place by pressing the rotation lock plate (black plastic on the front of the module). Screw it all the way down.



ATTENTION: Do not overtighten the tool in the tangential module.



FIG 2-13
INSERT THE KISS CUTTING TOOL

3. Press .

2.3.2 Installing Cutout Tool



WARNING: If the heavy-duty knife is not in use, it has to be removed from the machine and capped with a safety cap. Do this also when shutting down the machine in the evening.



1. In the Axis Control window click . If the tangential module is not mounted on the flatbed yet, install it as explained in section 2.2.
2. Align the pin in the slot as shown in the figure below and hold the internal shaft of the tangential module in its place by pressing the rotation lock plate (black plastic in front of module). Screw it all the way down.



ATTENTION: Do not overtighten the tool in the tangential module.

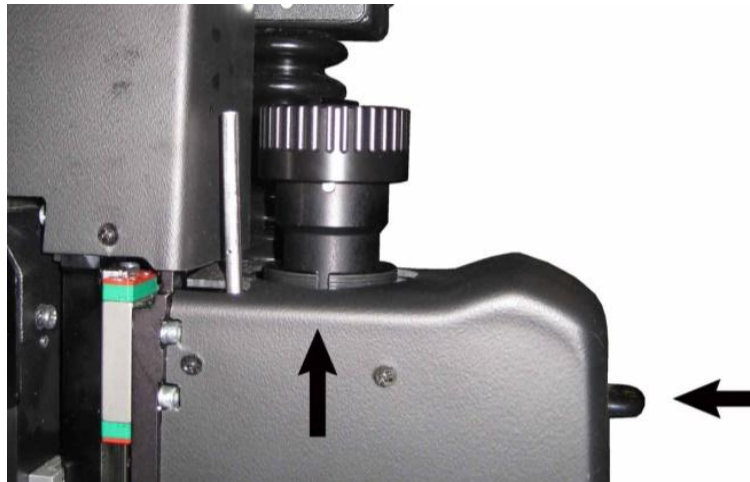



FIG 2-14
INSERT THE CUTOUT TOOL



3. Press .

2.3.3 Installing EOT



WARNING: If the knife is not in use and it is not completely protected by the gliding disk, it has to be removed from the machine and capped with a safety cap. Do the same when shutting down the machine in the evening.



1. In the Axis Control window click . If the tangential module is not mounted on the flatbed yet, install it as explained in section 2.2.
2. Align the pin in the slot as shown in the detail below. Make sure the EOT is slightly turned to the right, so that the position plate does not touch the positioning shaft. Hold the internal shaft of the tangential module in its place by pressing the rotation lock plate (black plastic in front of the module). Turn the screw all the way down.



ATTENTION: Do not overtighten the tool in the tangential module.

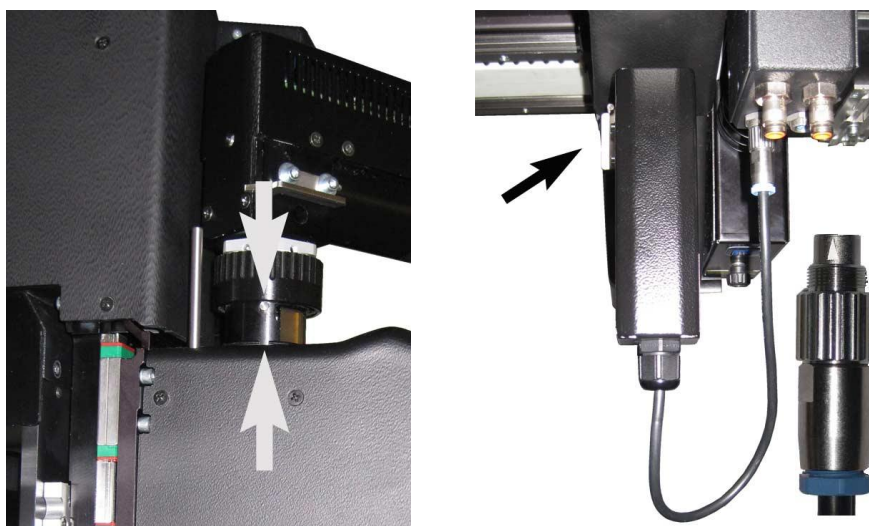



FIG 2-15
MOUNTING THE EOT

3. Once the tool is securely screwed, turn it this way the position plate clicks into the positioning shaft. Also connect the extra cable. There are two connections on the camera unit. If the module is mounted left to the camera unit, then use the left one, otherwise use the right one. Make sure to align the slotted connector with the little triangle facing upwards before screwing down the connector securely.



4. Press .

2.3.4 Installing the Creasing Wheel



1. In the Axis Control window click . If the tangential module is not mounted on the flatbed yet, install as explained in section 2.2.
2. Align the pin in the slot as shown in the figure below and hold the internal shaft of the tangential module in its place by pressing the rotation lock plate (black plastic in front of the module). Screw it all the way down.



ATTENTION: Do not overtighten the tool in the tangential module.

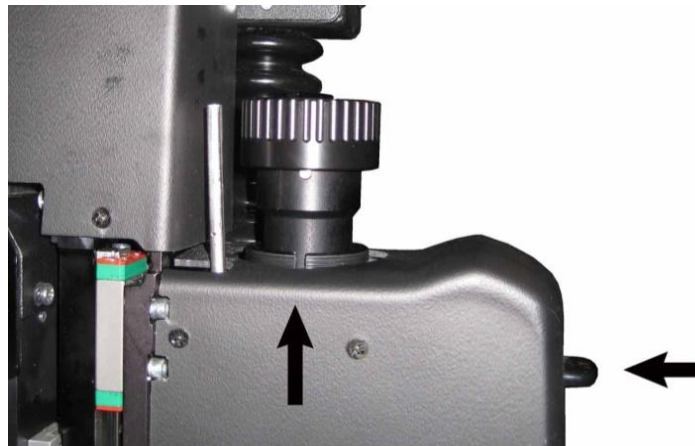



FIG 2-16
INSERT THE CREASING WHEEL



3. Press .

2.3.5 Installing the corrugated tool

1. The corrugated tool consists out of two main parts. These parts have to be taken apart before the tool can be mounted into the tangential module.



FIG 2-17
V-CUT TOOL IN TWO PARTS



2. In the Axis Control window click . If the tangential module is not mounted on the flatbed yet, install it as explained in section 2.2.
3. Align the pin in the slot as shown in the figure below and hold the internal shaft of the tangential module in its place by pressing the rotation lock plate (black plastic in front of the module). Screw it all the way down.



ATTENTION: Do not overtighten the tool in the tangential module (see usage of the tool wrench).

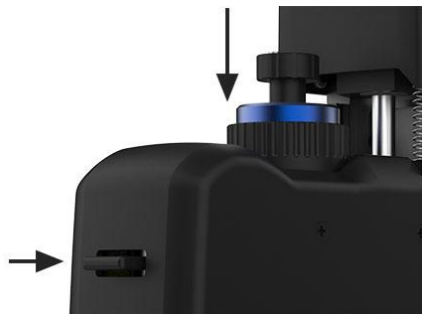

FIG 2-18
INSTALL THE UPPER PART OF THE V-CUT TOOL

4. Align the bottom part under the tangential module, slide it up and secure with the top screw (black arrow). The amount the knife protrudes can be adjusted by turning the silver-coloured ring (blue arrow).



FIG 2-19
INSTALL THE BOTTOM PART OF THE V-CUT TOOL

2.3.6 Removing the bottom part of the corrugated tool

1. Press the pin while you loosen the lower fixation screw until the pin clicks.

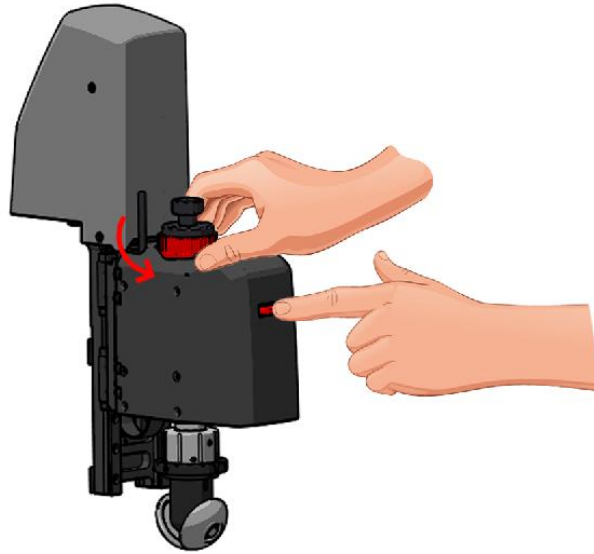

2. Loosen the top fixation screw by 2 or 3 rotations while keeping the pin pressed.

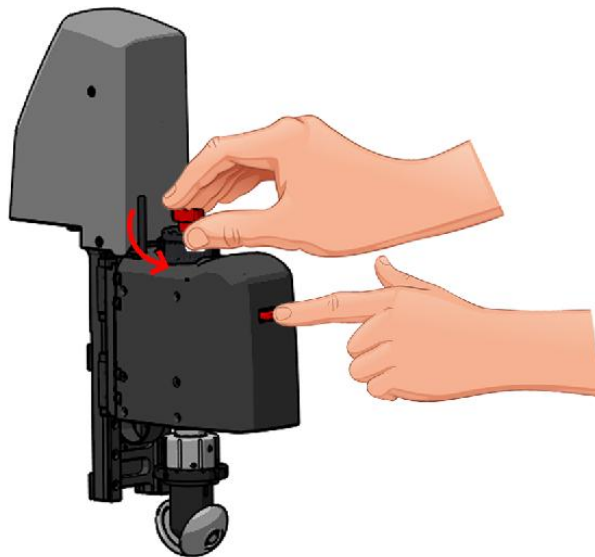

3. With your one hand on the fixation screw and your other hand supporting the bottom of the module, press on the fixation screw to disengage the bottom part of the tool from its conical seat. Alternatively, use the optional tool.

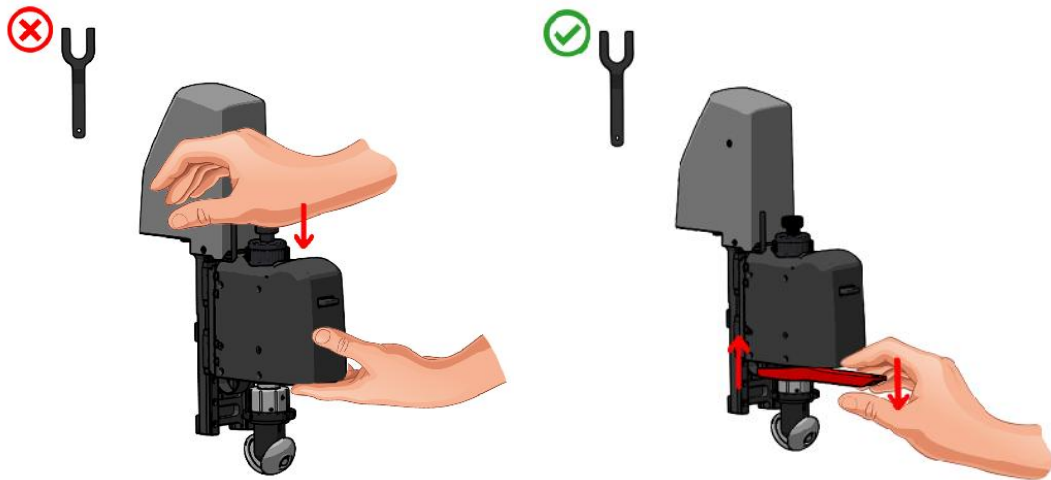

4. While holding the tool with your one hand, fully unscrew the top fixation screw with your other hand to remove the tool from the assembly.

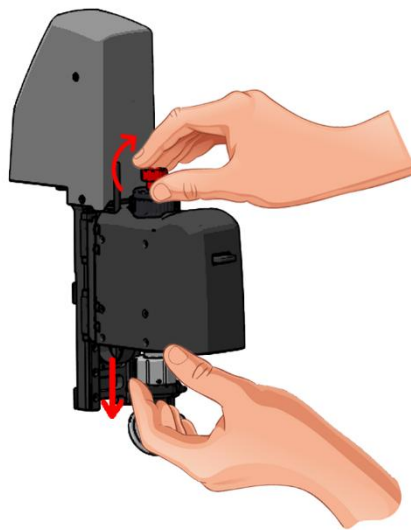

2.3.7 Installing the POT / POT-L



WARNING: Never leave the POT on the machine without the gliding disk. Mount the gliding piece immediately after the POT is mounted in the tangential module.



WARNING: The POT-L has no gliding disk, so do not leave it in the machine if it is not used. If it must stay in the machine, then put a warning sign on the machine.



1. In the Axis Control window click . If the tangential module is not mounted on the flatbed yet, install as explained in section 2.2.
2. Align the pin in the slot as shown in the detail below. Hold the internal shaft of the tangential module on its place by pressing on the rotation lock plate (black plastic in front of the module). Turn the screw all the way down.



ATTENTION: Do not overtighten the tool in the tangential module (see usage of the tool wrench).

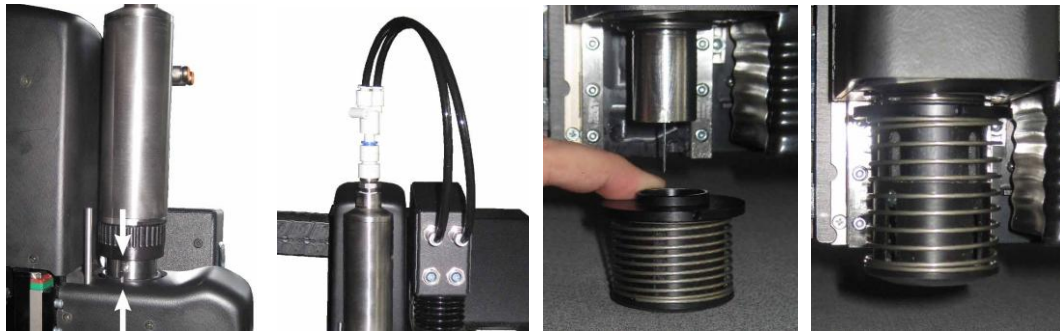

FIG 2-20
MOUNTING THE POT

3. Once the tool is securely screwed, put the gliding disk on the tool. Press the gliding disk together and slide it under the tool. Then mount it on the tool. The tool is slotted and a pin is situated inside the gliding disk. Make sure the gliding disk is seated correctly (cannot be turned around if it is seated correctly). For the F1612, connect the two air hoses to the camera unit. For the larger tables use the single tube with the large connector and insert the air hose to the connection marked with "POT" or "L"



4. Click .

2.3.8 Installing the V-Cut tool

- The V-Cut tool consists out of two main parts. These parts have to be taken apart before the tool can be mounted into the tangential module.



FIG 2-21
V-CUT TOOL IN TWO PARTS



- In the Axis Control window click . If the tangential module is not mounted on the flatbed yet, install it as explained in section 2.2.
- Align the pin in the slot as shown in the figure below and hold the internal shaft of the tangential module in its place by pressing the rotation lock plate (black plastic in front of the module). Screw it all the way down.



ATTENTION: Do not overtighten the tool in the tangential module (see usage of the tool wrench).



FIG 2-22
INSTALL THE UPPER PART OF THE V-CUT TOOL

- Screw the fitting aid in the bottom part of the V-Cut tool and align it under the tangential module in the top part of the V-Cut tool. Turn the big knob until it fits and then secure it firmly with the little knob on top.

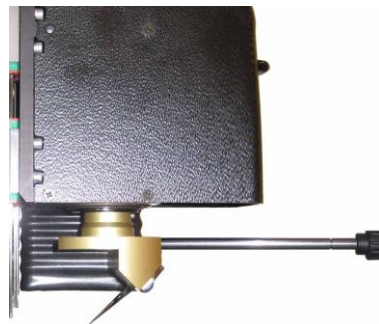



FIG 2-23
INSTALL THE BOTTOM PART OF THE V-CUT TOOL

2.3.9 Installing the rotary perforating knife

1. The rotary knife consists out of two main parts. These parts have to be taken apart before the tool can be mounted into the tangential module. Use a 10mm wrench to loosen the nut to replace the perforating knife, there is the small lock pin at the side to hold the knife holder while fastening it.



FIG 2-24
PERFORATING TOOL IN TWO PARTS

2. In the Axis Control window click . If the tangential module is not mounted on the flatbed yet, install it as explained in section 2.2.
3. Align the pin in the slot as shown in the figure below and hold the internal shaft of the tangential module in its place by pressing the rotation lock plate (black plastic in front of the module). Screw it all the way down.



ATTENTION: Do not overtighten the tool in the tangential module (see usage of the tool wrench).



FIG 2-25
INSTALL THE UPPER PART OF THE PERFORATING TOOL

4. Screw the fitting aid in the bottom part of the V-Cut tool and align it under the tangential module in the top part of the V-Cut tool. Turn the big knob until it fits and then secure it firmly with the little knob on top.



FIG 2-26
INSTALL THE BOTTOM PART OF THE PERFORATING KNIFE

2.3.10 Installing the Rotary Knife

The high torque rotary module has no tool holder. The knives need to be mounted directly in the module. This means that the complete module has to be taken from the machine to change the knife.



1. In the Axis Control window click . Loosen the screw at the side to remove the module.
2. Press the rotation lock pin to hold the knife. Consequently, loosen and remove the nut with a wrench # 10 mm.

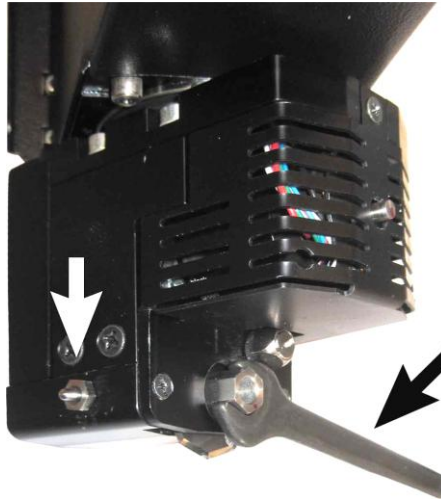



FIG 2-27
CHANGE KNIFE ROTARY MODULE

3. Remove the knife from underneath the module. To put a new knife, slide it from underneath into the module and put the knife over the bearing. Then, put the nut back and secure it with the wrench, while holding the rotation lock pin down.



FIG 2-28
PLACE NEW KNIFE IN ROTARY MODULE



4. Put the module back on the carriage, as described in section 0. and click .

2.3.11 Installing a router bit on standard miller

There are different models of the standard router (depending on the time the router was bought) however principle is always the same. The Below is a picture of a milling motor. Part 1 and part 2 should not be dis-assembled.

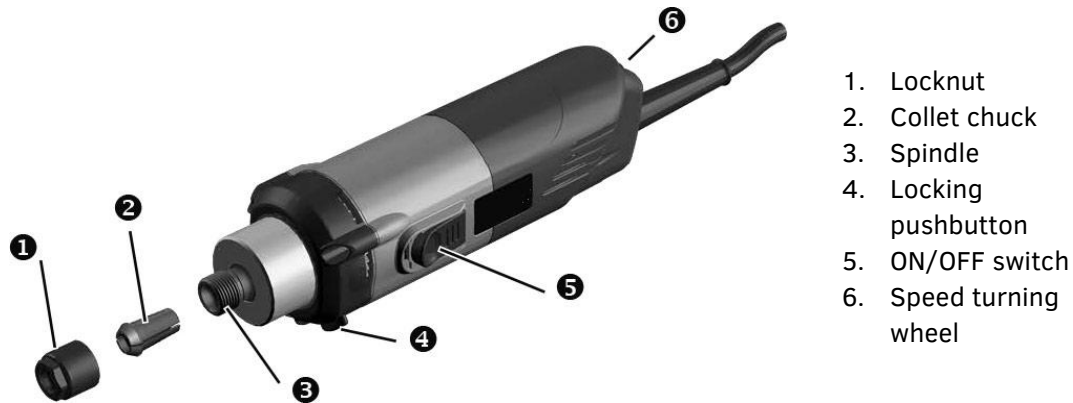



FIG 2-29
MILLING MOTOR

Router bits with a shank diameter of 3, 4, 6 and 8 mm can be mounted in the miller. To change a router bit, follow the below procedure.



1. Click .
2. Wait for the machine to stop.

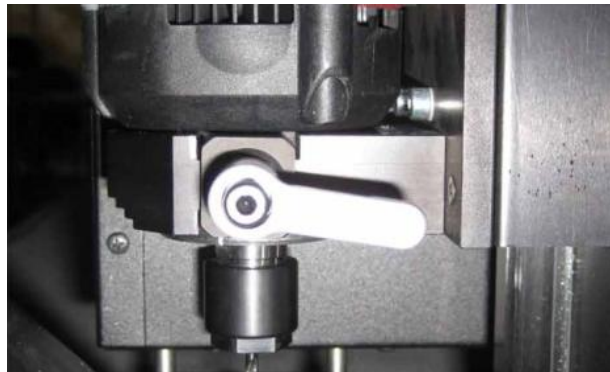

FIG 2-30
TAKING THE MILLER OUT OF THE ROUTER MODULE

3. Remove the miller from the router module.
4. Press on the locking pushbutton to hold the spindle in its place. Then loosen the locknut with a wrench # 17 mm or # 25 mm (depending on type of miller motor) a couple of turns. If the router bit, that will be mounted, has the same shank diameter, remove the bit.
5. Clean the collet with compressed air. Put in a new router bit. If the router bit has another shaft diameter, remove the collet completely and put in the correct one.

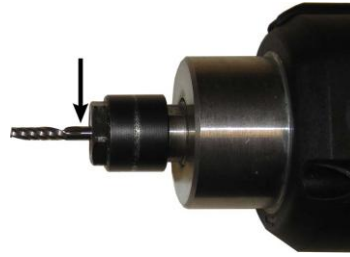

FIG 2-31
ROUTER BIT POSITION ON THE COLLET



ATTENTION: The ideal depth of a routing bit is when the distance between the end of the spiral, that guides the chips away, and the collet is 3 mm. If the routing bit is too long, make sure not to push the bit all the way down. This way, the end of the router bit stays free inside.



ATTENTION: Never tighten the nut when there is no router bit inserted. This might damage the collet. However, when tightening it with a bit inside, make sure it is tight.



ATTENTION: The distance between the tip of the routing bit and the collet has to be at least 15 mm (19 mm for firmware revisions lower than 024).



ATTENTION: Do not use the same bit for different types of material. Each material wears down the bit in a different way. It is possible the wear of one type of material does not affect the cutting quality in that type of material but does affect the cutting quality in another type of material.

6. Put the miller back in the router module (mind the orientation. The red part must be facing the module) and secure it with the handle.
7. Turn on the extractor height control handle, so that the extractor is set halfway (red plate is situated under the middle of the hole). For very thick material, the extractor will have to be set a bit higher. This setting is provisionally, so that the tip of the router bit is visible while up and down positions are set.



FIG 2-32
START POSITION EXTRACTOR BRUSH

2.3.12 Installing a router bit on HF miller

Below is a picture of a HF miller motor. Again, different models are used. Basically, the use is the same, however the installation of the collet differs according to the model used.

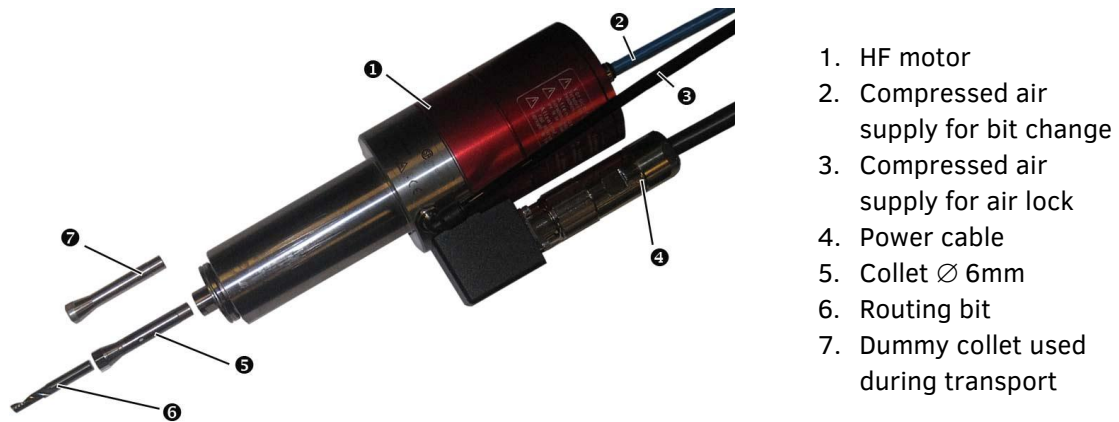

1. HF motor
2. Compressed air supply for bit change
3. Compressed air supply for air lock
4. Power cable
5. Collet \varnothing 6mm
6. Routing bit
7. Dummy collet used during transport

FIG 2-33
HF MILLING MOTOR

The miller is delivered with a collet of 6 mm. For transportation a dummy collet is used. This has to be removed on first use.



ATTENTION: Upon first use the dummy collet has to be replaced with a collet and routing bit in it. See maintenance section 4.1.2.11.



5045





4041



ATTENTION: Be sure to first identify your model and then check section 4.1.2.11 Maintenance HF miller. There is a very important difference between the different models.



1. Click , then click on the picture of the router module and click .
2. The knob on the brush has a 'locked' position. This position is used when changing a router bit. Push the brush upwards and turn the knob until it snaps into its locked position. The left figure shows the position during operation; the right figure shows the knob and brush in its position during a bit change.

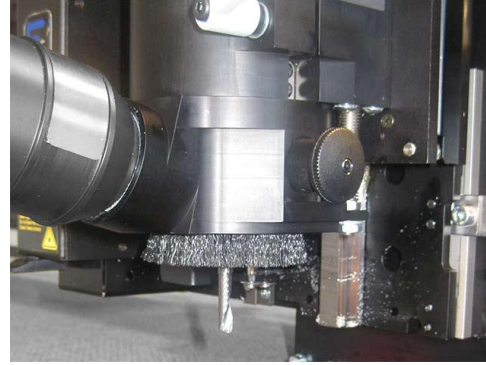
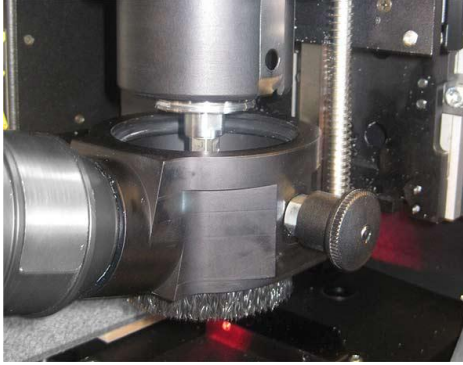

FIG 2-34
BRUSH POSITION FOR BIT CHANGE

3. Hold the bit and flip the switch on the back of the router module. The bit will come loose.

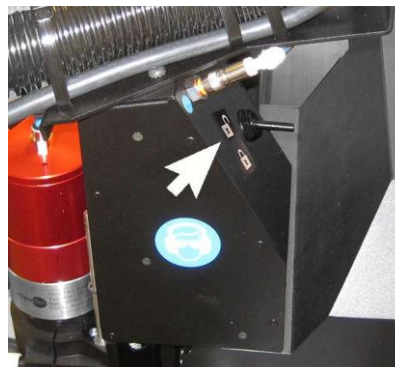

FIG 2-35
SWITCH FOR BIT CHANGE

4. Take the new bit and put it in the miller. Put the routing bit as deep as possible; however make sure the flute end stays free so the chip removal path is not obstructed.



FIG 2-36
SWITCH FOR BIT CHANGE



ATTENTION: Use only routing bits with a total length between 50 mm and 58 mm. It is not advised to use unbalanced routing bits.

5. Flip the switch on the back of the router again. The router will now clamp the routing bit.



Click  to finish the procedure.



ATTENTION: Never clamp the collet without a routing bit in it.



ATTENTION: Upon first use the miller has to run-in this is a sequence that takes about 30 minutes. This run-in procedure has to be done each time the miller has functioned less than 20 minutes in 3 weeks (an internal counter in Axis Control helps the user to remember) see maintenance section 4.1.2.9.

2.4 Tool/knife calibration with ADC

The ADC is integrated in the side covers of the table. Once installed and calibrated it is permanently available. The ADC works by interruption of a light beam. This is harmless for the tools. The sensor unit in the right-hand side cover is used to measure the tools in slot 2 & 3. The sensor in the left-hand side can measure the tools in slot 1.



NOTE: The drag module, which moves low over the table, can't pass over the ADC sensor units. The drag module must be used in slot 1. If the left ADC sensor is installed, the working area will be reduced when using the drag module in order to avoid that the module hits the ADC sensor unit. The front margin is moved 110 mm to the rear, so module 2 and module 3 can use the full table width.

2.4.1 General calibrations with the ADC

The down position of ADC controlled tools is set automatically each time the machine is switched on or when a tool is changed. The down position is a value, relative to the table height.



WARNING: The measurement of the POT knives isn't as accurate as on the other tools. Extra manual fine tuning may be required to have the most optimal down position. It is important to have stable pressure on the compressed air supply.

The *up position* should be set manually. The up position is the relative distance from the down position. Make sure the up-position measures significantly more than your material thickness.



To set the up position, first click . If Axis Control is not automatically selecting the tool, whose up position needs to be checked/set, click the picture of the corresponding module. Click 'Up position' in Axis Control or press 'Up' on the remote. Press the down arrow (computer or remote) until the tip of the knife is about 4 – 5 mm above the material, then press apply (computer) or A (remote). It is not necessary that the material is on the table, the up position can also be set if the thickness of the material is known. Just press the up/down arrow until the value is 4 – 5 mm higher than the thickness of the material.



FIG 2-37

SETTING THE UP POSITION WITH THE ADC

The *origin, lateral and longitudinal parameters* can also be set by the ADC¹. Those parameters are material independent and should only be set during first installation of a tool or when there are quality issues.



In order to automatically calibrate those parameters, first click . If Axis Control is not automatically selecting the tool, whose tool calibration needs to be checked/set, click the

¹ Except for bevel-cut knives. In the case of a bevel-cut knife, always calibrate the origin, lateral, and longitudinal parameters manually. This procedure is explained in section 2.5.1.7.

picture of the corresponding module. Then click . The ADC will now measure the three parameters and store the values.

Different materials (or speeds) may need different down positions. The down position can be adjusted manually and indicates the difference compared to the calibrated table height. If the tool is measured again it will maintain the manually calibrated shift to make sure the cutting result is the same as before.



NOTE: If a protection mat is used, the down position should be around 2.5 mm. With the routing tool, the routing mat should always be used. The machine takes this into account, so the down position values should also be around 0 mm.



WARNING: The best way to prepare for a depth test is to put the media a couple of centimetre to the left of the machine origin. Then set the origin a centimetre or two inside the media







To adjust the cutting depth, click . If Axis Control is not automatically selecting the tool, who's down position needs to be checked/set, click the picture of the corresponding module. Click 'Down position' in Axis Control or press 'Down' on the remote. Then move the tool, so that the knife tip is set to the right of the loaded media. Then click  or test on the remote. Check the cutting depth after the test has been done. If the cutting depth needs to be adjusted, then click on the down arrow. Wait for the tool to come back to its starting point. Then adjust the depth by clicking on the up arrow or down arrow and redo a test to check if it is OK or not. When the cutting test is OK, click  or  on the remote.



FIG 2-38
CHECKING THE CUTTING DEPTH

Another special parameter is the blade compensation parameter. In order to obtain a smooth curve, the knife orientation needs to be set in the direction of the cutting line. When thick media is cut, the knife orientation will only be correct at the bottom of the material. At the top of the material the knife orientation will not be set in the direction of the cutting line. In order to compensate this, the parameter blade compensation is used. This parameter anticipates the knife orientation (distance is set with the parameter), so the top cut and the bottom cut are both closest to the ideal cutting line. However, this parameter can never compensate a 100% due to the physical limitations of the knife and cutting process. Therefore, it is also recommended to transform small curves in the design into corners or polygons (depending on the design itself).

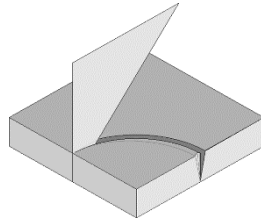

FIG 2-39
KNIFE ORIENTATION IN THICK MATERIAL

To set the parameter, do following. Click 'Blade compensation' (it becomes blue highlighted). Then click 'Test'. The cutter will cut out a small square with rounded corners. Fill in a value and do the test. A good starting value is the length of the overcut, visible in the knife depth test.

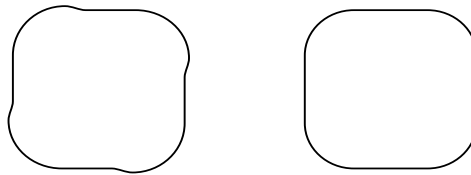

FIG 2-40
TEST PATTERN CUTOUT TOOL – BLADE COMPENSATION PARAMETER

The picture above shows two possible results of the blade compensation test. In the left pattern the blade compensation value is too low. In the right pattern it is set correctly. If the blade compensation is set too high, the result will be more deformed and distorted. Therefore, it is best to execute the test from a value, which is too low in relation to the correct value.



NOTE: Blade compensation values of the POT are limited due to the geometry of the knives.

2.4.2 Practical tool changes with the ADC

When the machine has been set up, then a tool change is very easy. When frequently used materials are processed, just change the tool and wait for the ADC to set the down position. Then check/set the up position to be sure the tool will not hit the material while it is moving in the up position.

However, there are some tool specific actions, which are necessary during first installations or when the parameters need to be altered slightly for different sorts of material. These steps are explained in the sections below.

2.4.2.1 Calibrating the Kiss Cutting Knife with the ADC

The kiss cut tool is a special case. The cutting depth is mechanically controlled by the pressure and the amount that the knife protrudes between the two bearings of the nose piece.

When the down position is set for the first time, it is best to make sure the knife does not protrude. The ADC will then set the down position, using the bottom of the two bearings in the nose piece. The up position will then be set automatically 4 mm (0.16") higher. This is enough because the maximum cutting depth of the kiss cutting tool is 1.2 mm (50 mils).

Procedure to set the cutting depth for the kiss cutting knife:

Put the knife in the kiss cutting tool and make sure the knife does not protrude (it is best to set it flush, the cutting depth can then be set quickly). Do this by touching the bearings or by checking on a piece of paper.

Then install the kiss cutting knife and let the ADC measure the down position.

Check if the origin of the loaded media is still set correctly. If not, adjust it and click . If Axis Control is not selecting the correct module to calibrate automatically, correct it by clicking the picture of the module.

Turn the knife holder to set the cutting depth. If the start position was flush with the bearing, then know that one quarter of a turn is setting the cutting depth about 0.12 mm (5 mils) deeper.

Press  to do a knife depth test. Check the result. Change the knife depth, if necessary, or if the pressure is not high enough/too high. Adjust by turning the adjust screw.

Finally calibrate the knife parameters. Do this by clicking the  button. Axis Control will pause just before the tests and prompt the user to take off the nose piece.

2.4.2.2 Calibrating the Cut Out Knives with the ADC

The following applies for the Heavy Duty cutout tool, the single edge cutout tool and the double edge cutout tool.

The general calibration procedure with the ADC applies for these three tools. Install the tool, let the ADC set the down position. Check the up position. And then do the extra calibration of the knife parameters.

When the tool is installed for the first time, it is advised to do a knife depth test and adjust, if necessary. The knife depth can differ a little bit from media to media. The softer the media that needs to be cut, the deeper the knife depth needs to be set. Softer backing/media bends a little bit just before the knife pierces through the media.

2.4.2.3 Calibrating the EOT with the ADC

One of the typical properties of an oscillating tool is that the cutting depth depends on the used cutting speed. The faster the cutting speed, the deeper the knife depth needs to be set.

To calibrate the EOT, perform the standard calibration with the ADC. Install the tool, let the ADC set the down position. Check the up position. Then do the extra calibration of the knife parameters.

Select the down velocity that will be used in the actual job and set the oscillating frequency. Then check the cutting depth as described in section 2.4.1.

2.4.2.4 Calibrating the Creasing Wheels with the ADC

The ADC can calibrate the depth and the other parameters of the creasing wheel as described in the general calibration. However, working with creasing wheels requires some extra settings. To calibrate a creasing wheel, do the standard calibration with the ADC. Install the tool, let the ADC set the down position. Check the up position. Then do the extra calibration for the origin, latitude and longitude.

After this the creasing depth needs to be checked. There are two main types of materials to crease. Corrugated media and none corrugated media.

The extra parameters flute direction and down position offset are only used for corrugated media. For none corrugated media set the flute direction to None and set the down position offset to 0.

To set the down position click 'Down position' in Axis Control or press 'Down' on the remote. Then press the down arrow (computer or remote) until the creasing wheel pushes in the material. Press Test. The flatbed makes a pattern. Check if the creasing wheel is set deep enough. If not, adjust the down position a bit more. The pattern consists out of an array of horizontal and vertical lines.

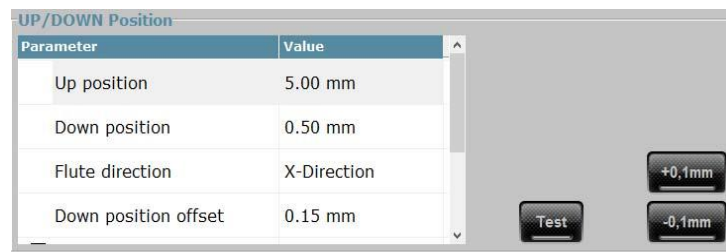
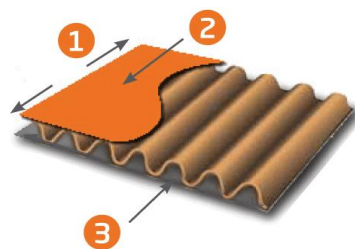

FIG 2-41
SETTING OF CREASING DEPTH PARAMETERS

If the media is corrugated, then the creasing depth will be too much in one direction (flute direction). In this case set the flute direction correctly and set an offset for this direction. Then do the depth test again. Adjust the down position offset, if necessary.



1. Flute direction
2. Top liner (outside)
3. Bottom liner (inside)

FIG 2-42
FLUTE DIRECTION CORRUGATED CARDBOARD

2.4.2.5 Calibrating the corrugated tool with the ADC

The cutting depth of the corrugated tool is mechanically controlled by the pressure and the amount that the knife protrudes between the two wheels. The calibration of the tool consists out of two parts. First the knife itself is calibrated (initial depth and other knife parameters) then the actual cutting depth is set by doing small tests on the actual material because the final setting is media dependent.

To calibrate the corrugated tool install the tool and turn the wheels to the maximum up position so the knife is completely visible (silver coloured ring – blue arrow).



FIG 2-43
SETTING OF CREASING DEPTH PARAMETERS

Then let the ADC set the down position. Check the up position. Then do the extra calibration of the knife parameters.

Finally a test needs to be done with the actual media that is going to be cut. Since the amount the knife protrudes is set by turning on the silver coloured ring, it needs to set/checked each time a job is started. A possible solution to avoid this would be to have several tools for several media.

With very heavy cardboard it is possible that the knife depth needs to be adjusted to get through the media.

2.4.2.6 Calibrating the POT with the ADC

As mentioned earlier the down position of the POT tool is not as accurate as with the other tools. The reason is threefold. First of all there is the specific nature of a pneumatic tool. Secondly, this tool needs to cut into a very wide range of media harnesses, from light foam to sandwich boards with PVC top and bottom layers. Finally, the typical properties of an oscillating tool interfere, as well: the speed influences the cutting depth.

The calibration of this tool is the same as described in the section of the general calibration of a tool with the ADC. However, checking the knife depth needs be done during each material change (even if the material is the same, but differs in thickness).

2.4.2.7 Calibrating the V-Cut knives with the ADC

The down position that is set by the ADC is 0.5 mm higher than the table surface for the V-Cut knife. This is the case because the V-Cut knife never cuts completely through the material. The below figure explains how the ADC calibrates the knife (top figure) and how the knife should eventually be calibrated (bottom figure). This cannot be done automatically because this calibration is media dependent. However, once calibrated, the adjustments are kept in the memory, which means that there is no need for extra adjustments if the same media is used and the knife is re-installed on the machine.

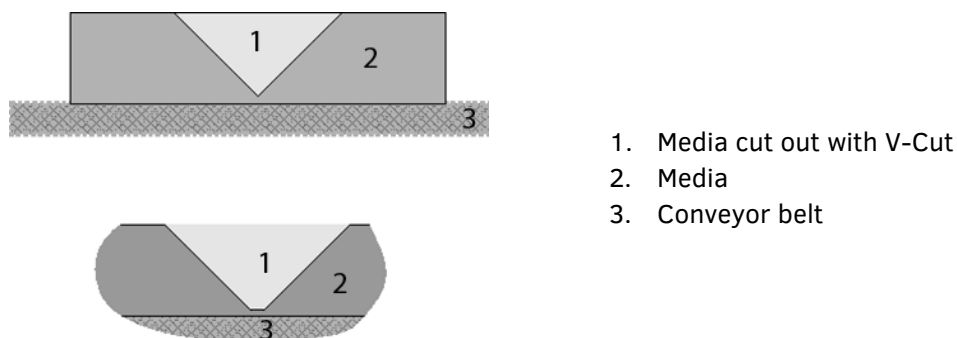

FIG 2-44
CORRECT V-CUT

In order to calibrate a V-Cut knife, perform the standard calibration with the ADC. Install the tool, let the ADC set the down position. Check the up position. Then do the extra calibration for the origin, latitude and longitude as explained in chapter 2.5.1.6. The extra parameter lateral gap has to be set by hand. The best way to check the V-Cut parameters is by cutting a square with an oscillating knife and by cutting one V-Cut line in the middle of the square from left to right. Then remove the square from the media, bend it and check the angle and gap. To start this test click on lateral gap and hold down the control key while clicking on the test button.



WARNING: It is mandatory to move the knife to the right of the media before doing a depth test. If this is not done, then the knife tip will be destroyed if the knife depth is adjusted.

The knife depth may need to be adjusted, so the knife scratches scarcely in the bottom liner and in case the cut out part is not completely loose after the cut. Usually, the angle of the bend improves if the lateral gap is set to 20 or 30.

2.4.2.8 Calibrating the bevel-cut knife with the ADC

The down position that is set by the ADC is 0.5 mm higher than the table surface for the bevel-cut knife. This is the case because the bevel-cut knife never cuts completely through the material. The below figure explains how the ADC calibrates the knife (top figure) and how the knife should eventually be calibrated (bottom figure). This cannot be done automatically because this calibration is media dependent. However, once calibrated, the adjustments are kept in the memory, which means that there is no need for extra adjustments if the same media is used and the knife is re-installed on the machine.

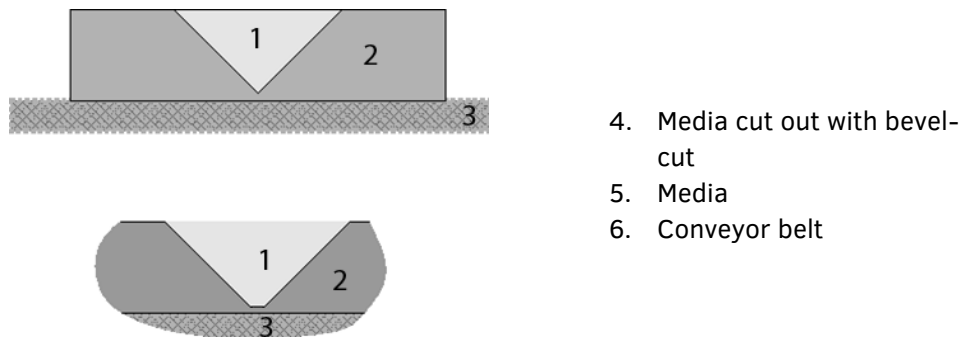

FIG 2-45
CORRECT BEVEL-CUT

In order to calibrate a bevel-cut knife, perform the standard calibration with the ADC. Install the tool, let the ADC set the down position. Check the up position. Then do the extra calibration for the origin, latitude and longitude as explained in chapter 2.5.1.7. The extra parameter lateral gap also has to be set manually. The best way to check the bevel-cut parameters is by cutting a square with an oscillating knife and by cutting one bevel-cut line in the middle of the square from left to right. Then remove the square from the media, bend it and check the angle and gap. To start this test, click on lateral gap and hold down the control key while clicking on the test button.



WARNING: It is mandatory to move the knife to the right of the media before doing a depth test. If this is not done, then the knife tip will be destroyed if the knife depth is adjusted.

The knife depth may need to be adjusted, so the knife scratches scarcely in the bottom liner and in case the cut-out part is not completely loose after the cut. Usually, the angle of the bend improves if the lateral gap is set to 20 or 30.

2.4.2.9 Calibrating the perforating knife with the ADC

The ADC can calibrate the depth and the other parameters of the perforating knife as described in the general calibration. It can also check the up position.

The standard F Series conveyor belt does not give sufficient support to do a full perforation cut through flexible or thin materials. To cut through, it is recommended using a stiffer underlay. By putting an MDF board in between, the necessary resistance is created for the cutter blade. The MDF is soft enough not to damage the knife and porous enough to distribute the vacuum to the sheet. Doing so alters the needed knife depth setting so the knife depth might need to be adjusted slightly. Perform a depth test in order to check if the knife depth needs to be adjusted. Also take in account that in the driving software the knife cannot be set to cut deeper. Only adjustments for cutting less deeper can be done in the software.

2.4.2.10 Calibrating the Rotary knife with the ADC

The ADC can calibrate the depth and the other parameters of the rotary knife as described in the general calibration. It can also check the up position.

The rotary knife is ideal to cut fabrics. Different fabrics contain different fibers, so the knife depth might need to be adjusted slightly.

When a new fabric is tested, first perform the automatic calibration. Then set the rotating speed and perform a depth test in order to check if the knife depth needs to be adjusted.

2.4.2.11 Calibrating the routing bit with the ADC

The routing bit only has three parameters. The up position, the down position and the down delay. The down position can be set with the ADC. The up position is best set with the material on the machine. The height of the brush can then also be adjusted when the up position is set. The down delay needs to be adjusted to be able to drill holes in relatively soft materials.

The router module has another origin position in reference to the camera/positioning laser than the tangential module. When the router is used for the first time, then the center of the router bit needs to be calibrated in reference to the camera.

This calibration is mandatory if the router before the ADC will become active. In order to calibrate the origin for the router, follow the below procedure.

1. Load the media, install the module and tool.



2. Click  and click the picture of the router. Set the up and down position of the router manually. (the down position does not have to be exact but just deep enough to drill a hole). After the origin is set, the depth of the router bit can be set automatically with the ADC.
3. Click the picture of the camera unit in the window.
4. Click slot 3. The machine will drill a hole in the media with the router.

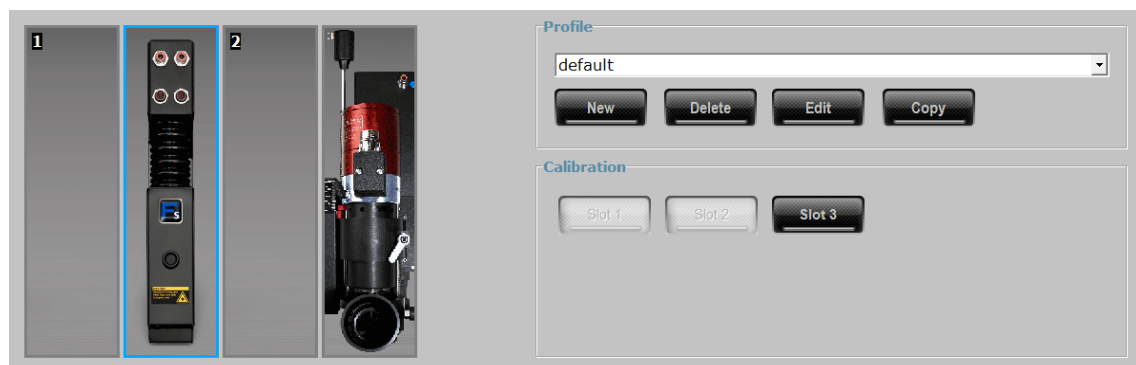

FIG 2-46

CALIBRATION DISTANCE ROUTER MODULE - CAMERA



5. You have the choice to calibrate automatically or to set the miller with the arrow keys in the center above the drilled hole.



2.5 Tool/knife calibration without ADC

2.5.1 Calibration of the tools/knives during first use

All the relevant parameters for a certain knife/tool need to be calibrated the first time the tool is installed. Once calibrated, all settings are stored internally and a tool change can then be done quicker, as described in section 2.5.2.

2.5.1.1 Calibration of the Kiss Cutting knife

- After installation of the tool, click . Axis Control will give a reminder in order not to forget to calibrate the tool before using it in case it just has been changed. Click  to acknowledge. Check if the origin of the loaded media is still set correctly. If not, adjust it and click . If Axis Control is not selecting the correct module to calibrate automatically, correct it by clicking the picture of the module. If the remote is used to choose the module, press the module several times until the correct one is chosen. The lights on the remote show which module is currently chosen to calibrate. The left light is module 1; the light next to that is module 2 and the second last light in the row is module 3. First the up/down parameters need to be set.

UP/DOWN Position	
Parameter	Value
 Up position	4,00 mm
 Down position	-50,00 mm
 Velocity	800 mm/s
Lift velocity	200 mm/s
Lowering velocity	200 mm/s







FIG 2-47
UP/DOWN PARAMETERS KISS CUTTING TOOL

- Set the same value for the velocity as the one that will be used in the job. Leave the lift and lowering velocity at 200 mm. The lowering velocity can be set to a lower value if the material, that needs to be cut, is very tough. Calibrate the down position by clicking 'Down position' in Axis Control or press 'Down' on the remote. Press the down arrow (computer or remote) until the nose piece and knife holder are pushed into the tool holder for about 1 to 2 mm (see picture below).

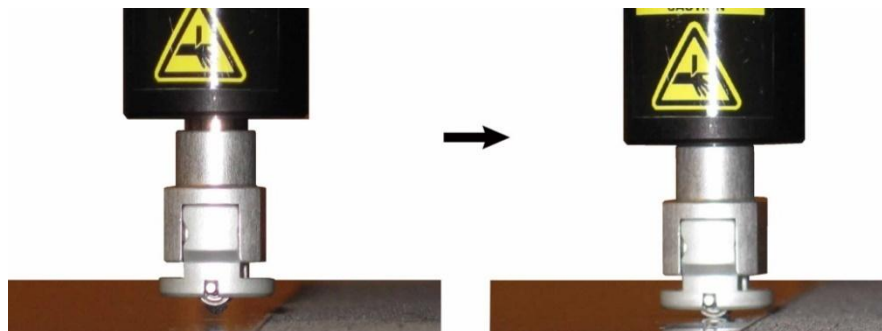

FIG 2-48
SETTING THE DOWN PARAMETER KISS CUTTING TOOL

- Then press 'Test'. The flatbed will now cut out two squares. Peel them out and check if the pressure and knife depth are set correctly. If the knife depth is not correct, adjust by turning the knife holder (a quarter of a turn changes the knife depth by 0.12 mm). If the pressure is not high enough, adjust by turning the adjust screw. If the depth is set, press Apply (computer) or A (remote).



NOTE: Check the imprint the bearings of the nose piece make. If they are clearly visible it means the pressure is set too high, which will affect the cutting quality.

- The up parameter is automatically set 4 mm higher. Normally it is not necessary to raise this value. Should it be necessary, click 'Up' (remote) or 'Up position' (Axis Control). Then press the up arrow to adjust. Do not forget to confirm the new setting.
- Now, the knife parameters need to be set. This can't be done with the remote. In Axis Control, click the parameter that needs to be checked or set. Then click 'Test'. Check the pattern that was cut out. In Axis Control a window opens with a drawing of the cut out pattern. In this window click the place where the correct pattern was cut out. It is possible that the test needs to be done more than once if the setting of the parameter was not satisfactory.

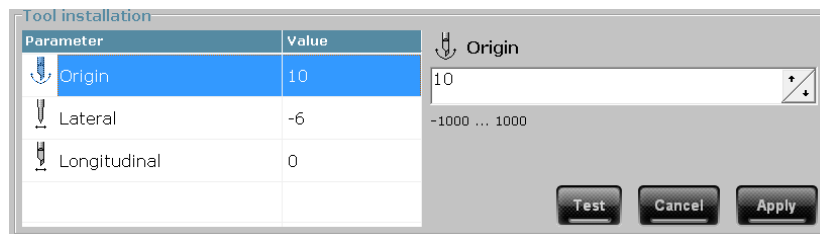

FIG 2-49

SETTING OF KNIFE PARAMETERS – KISS CUTTING TOOL



ATTENTION: Failing to set the knife parameters correctly will result in poor cut quality and shorter lifetime of the blades.

Setting the origin parameter.

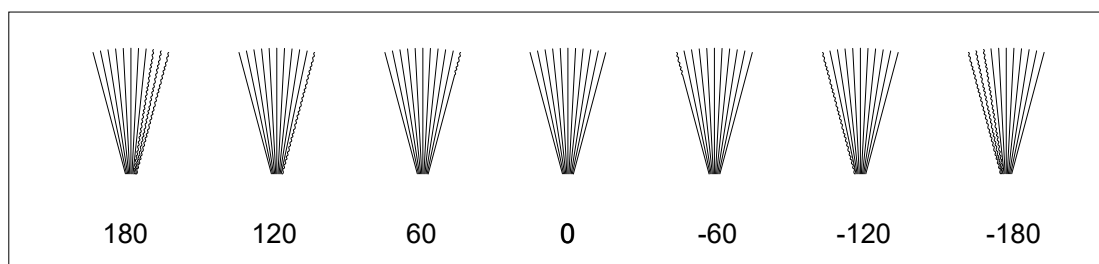

FIG 2-50

TEST PATTERN KISS CUTTING TOOL ORIGIN PARAMETER

The fan shaped pattern should have a clear cut line in the middle. The ones at the sides show burs. Check which pattern comes closest to the correct pattern and then choose this one in Axis Control. The values in the figure above are not cut out. They are indicative so the user can adjust the value manually should it show that the correct pattern is probably just in between two cut out patterns.

Some thick or hard materials may damage the knife with this test. There is a special origin test for those kinds of materials. Just hold down the Ctrl key while clicking the test button to start this test.

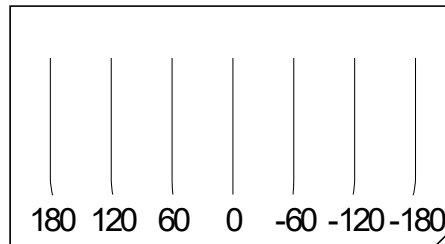

FIG 2-51
ORIGIN PATTERN TEST FOR THE KISS CUTTING KNIFE

The cutter will cut out a test pattern and a window will pop up in Axis Control. The special origin test looks like the pattern above. Look for the straightest line between the 7 lines. When the origin is not correct, then the knife is pushed in the media under an angle (in reference to the cut direction) and then dragged straight into the cut direction. This means that the beginning of the line needs to be inspected. The figure above contains values; the cut out pattern doesn't. These values are different than the current value. Check for the straightest line and select the according one in the pop-up window. The extended cut out test goes from +180 over 0 to -180. The values may differ depending on the firmware revision. However, the procedure is the same. Just click the most correct line.



NOTE: With some materials it is necessary to use a magnifying glass to check the start of the line. The start will then look something like the picture on the right.



Setting the lateral parameter.

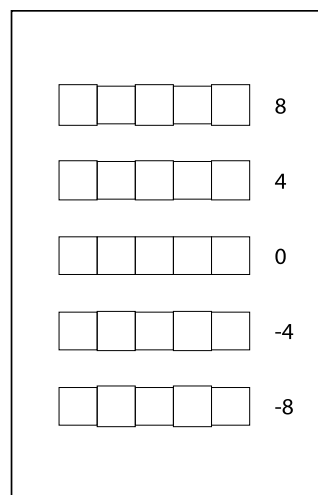

FIG 2-52
TEST PATTERN KISS CUTTING TOOL LATERAL PARAMETER

The squares should all be equal in size and be cut out at the same height. Check which pattern comes closest to the correct pattern and then choose this one in Axis Control. The values in the figure above are not cut out. They are indicative, so the user can adjust the value manually should it show the correct pattern is probably just in between two cut out patterns.



ATTENTION: If it is impossible to set the lateral parameter in order to cut out the correct pattern, this means that the origin is still not set correctly. If this is the case, change the origin first before adjusting the lateral parameter again. The combination origin – lateral parameter can also be checked in the test pattern of the origin test. If pattern 1 weeds out without it catching in the middle, both the origin and lateral parameter are set correctly.

Setting the longitudinal parameter.

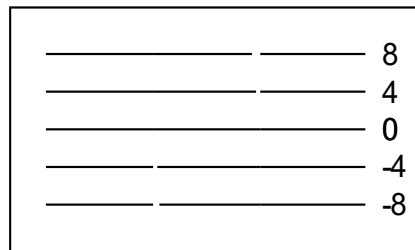

FIG 2-53

TEST PATTERN KISS CUTTING TOOL LONGITUDINAL PARAMETER

The horizontal cut lines should meet. Check which pattern comes closest to the correct pattern and then choose this one in Axis Control. The values in the figure above are not cut out. They are indicative so the user can manually adjust the value should it show the correct pattern is probably just in between two cut out patterns.

Setting the blade compensation parameter.



This parameter is ideal for thicker material that will not be cut with a kiss cutting knife.

2.5.1.2 Calibration of the Cutout knife



WARNING: If the heavy-duty knife is not in use, it has to be removed from the machine and capped with a safety cap. Do this also when shutting down the machine in the evening.



1. Click  if the tool was just changed. Axis Control will give a reminder in order not to forget to calibrate the tool before using it. Click  to acknowledge. Check if the origin of



the loaded media is still set correctly, if not, adjust it and click . If Axis Control is not selecting the correct module to calibrate automatically, correct it by clicking the picture of the module. If the remote is used to choose the module, press several times on the module until the correct one is chosen. The lights on the remote show which module is currently chosen to calibrate. The left light is module 1; the light next to that is module 2 and the second last light in the row is module 3. First the up/down parameters need to be set.

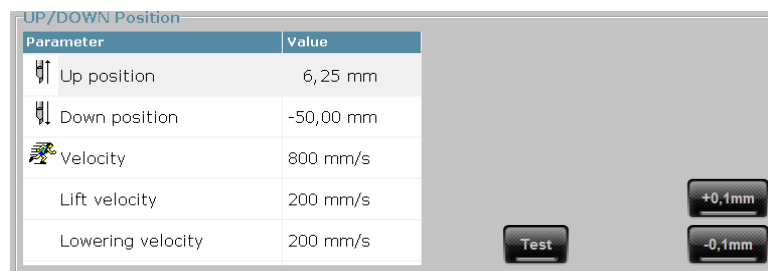

FIG 2-54

UP/DOWN PARAMETERS CUTOUT TOOL

- Set the same value of velocity as the one that will be used in the job. Leave the lift and lowering velocity at 200 mm. The lowering velocity can be set to a lower value if the material that needs to be cut is very tough. Calibrate the up position by clicking 'Up position' in Axis Control or press 'Up' on the remote. Press the down arrow (computer or remote) until the tip of the knife is about 4 – 5 mm above the material. Press apply (on computer) or A (on remote).
- Calibrate the down position. To calibrate the down position, click 'Down Position' in Axis Control or press 'Down' on the remote. It is best to first move the knife next to the media with the right arrow (on computer or on remote). Otherwise it is not possible to see how deep the knife is set. Then press the down arrow (computer or remote) until the tip of the knife just touches the grey mat. A white sheet of paper can be used to see exactly where it touched the mat. The sheet can be put behind the knife for a visual check or under the knife to check physically. Then press Test. The flatbed will now cut out two squares. Check if the knife is set deep enough. If not, adjust the down position a bit more. Do not forget to first click Apply before another parameter is chosen. Otherwise the value is not saved.



ATTENTION: Make sure the down position is not set too deep. Otherwise the mat will wear down fast. Therefore, it is recommended to do following. If the correct down position is found, set the down position two steps higher and do the test again. If the knife does not cut deep enough, set the down value again to what it was before. If it still cuts completely through the material, this means the down position was set too low and needs to be changed.

- After this, the knife parameters need to be set. This can't be done with the remote. Click the parameter that needs to be checked or set in Axis Control. Then click Test. Check the pattern that was cut out. A window opens in Axis Control with a drawing of the pattern that was cut out. In this window, click the place where the correct pattern was cut out. The test will differ according to the parameter that was chosen (highlighted in blue).

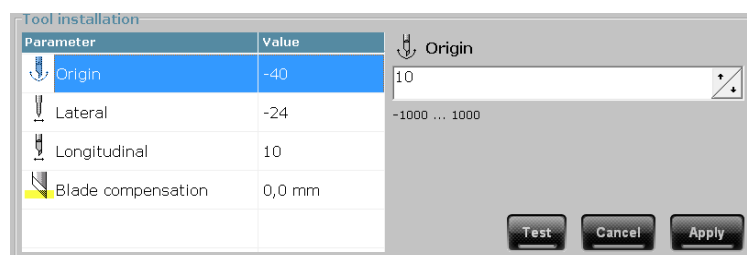

FIG 2-55

SETTING KNIFE PARAMETERS CUTOUT TOOL

Setting the origin parameter.

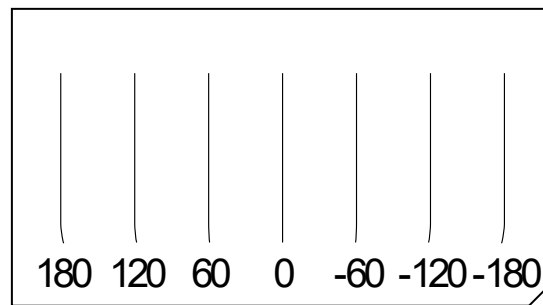
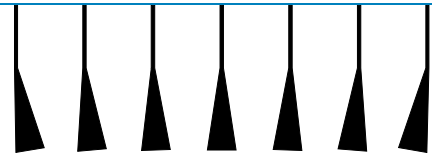

FIG 2-56
ORIGIN PATTERN TEST FOR THE CUTOUT KNIFE

The cutter will cut out a test pattern and a window will pop up in Axis Control. The origin test looks like the pattern above. Look for the straightest line between the 7 lines. When the origin is not correct, the knife is pushed in the media under an angle (in reference to the cut direction) and then dragged straight into the cut direction. This means that the beginning of the line needs to be inspected. The figure above contains values; they are not cut out. These values are different from the current value. Check for the straightest line and select the according one in the popup window. The values are indicative, so the user can adjust the value manually should it show the correct pattern is probably just in between two cut out patterns.



NOTE: With some materials it is necessary to use a magnifying glass to check the start of the line. The start will then look something like the picture on the right.



Setting the lateral parameter.

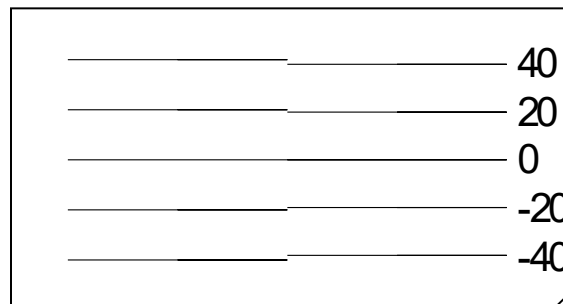

FIG 2-57
LATERAL PATTERN TEST FOR THE CUTOUT KNIFE

The horizontal lines are cut out in two parts. Each line is cut from the middle to the side. If the lateral parameter is not set correctly, the lines do not meet in the middle but will be shifted. The figure contains values; the cut-out pattern doesn't. The values in the picture are different from the current value. Check for the line where there is no shift in the middle and select the according one in the popup window. The values are indicative, so the user can adjust the value manually should it show the correct pattern is probably just in between two cut out patterns.

Setting the longitudinal parameter.

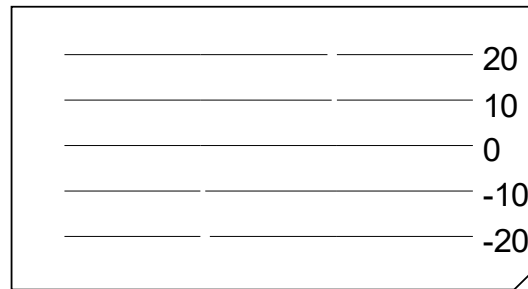

FIG 2-58
LONGITUDINAL PATTERN TEST FOR THE CUTOUT KNIFE

The horizontal cut lines should meet. Check which pattern comes closest to the correct pattern and then choose this one in Axis Control. The values in the figure above are not cut out. They are indicative, so the user can adjust the value manually should it show the correct pattern is probably just in between two cut out patterns.

There is a second long test (shown in the figure below). Just hold down the Ctrl key while clicking the test button to start this test.

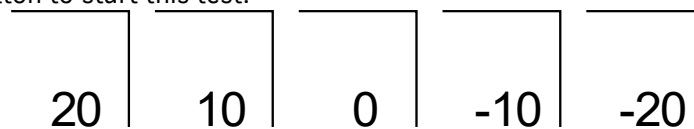

FIG 2-59
ORIGIN PATTERN TEST FOR THE KISS CUTTING KNIFE

The cutter will cut out a test pattern and a window will pop up in Axis Control. The special origin test looks like the pattern above. With the single edge knife and the heavy-duty knife, look for the pattern where the horizontal line starts flushing with the vertical line. With the double edge knife, look for the pattern where the overcut in the corner is the same on both lines. The values may differ, depending on the firmware revision. However, the procedure is the same. Click the most correct pattern.

Setting the blade compensation parameter.

This is only necessary for materials of more than 2 to 3 mm thickness. When thick media is cut, the knife will bend in the corners. As a result the cut line on top of the media will be shifted a little bit in reference to the cut line in the bottom of the media. The smaller the curve, the tougher and the thicker the media and the more this will be visible. To compensate this, you can use the parameter blade compensation. This parameter anticipates the knife orientation (distance is set with the parameter), so the top cut and the bottom cut are both closest to the ideal cutting line. However, this parameter can never compensate a 100% due to the physical limitations of the knife and cutting process. Therefore, it is also recommended to transform small curves in the design into corners or polygons (depending on the design itself). To set the parameter, do following. Click Blade compensation (it becomes blue highlighted). Then click Test. The cutter will cut out a small square with rounded corners. Fill in a value and do the test. A good starting value for the heavy-duty knife is a bit less than half of the thickness of the media. For the single edge a good starting value is a bit less than a quarter of the thickness of the media. This is a trial-and-error test. Values between 0 and 1 mm are not used; they are by default set at 1 mm.

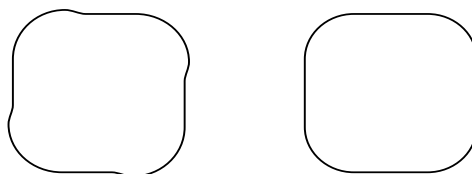

FIG 2-60

TEST PATTERN CUTOUT TOOL BLADE COMPENSATION PARAMETER



The picture above shows two possible results of the blade compensation test. In the left pattern the blade compensation value is too low. In the right pattern it is set correctly. If the blade compensation is set too high, the result will be more deformed and distorted. Therefore, it is best that this test is done from a value, which is too low relative to the correct value.



ATTENTION: Failing to set the knife parameters correctly will result in poor cut quality and shorter lifetime of the blades.



2.5.1.3 Calibration of the EOT





1. Click  if the tool just has been changed. Axis Control will give a reminder in order not to forget to calibrate the tool before using it. Click  to acknowledge. Check if the origin



of the loaded media is still set correctly. If not, adjust and click . If Axis Control is not automatically selecting the correct module to calibrate, correct it by clicking on the picture of the module. If the remote is used to choose the module, press several times on the module until the correct one is chosen. The lights on the remote show which module is currently chosen to calibrate (M1, M2 or M3, counting from the left). First the up/down parameters need to be set.

UP/DOWN Position	
Parameter	Value
 Up position	12,25 mm
 Down position	-50,00 mm
 Velocity	800 mm/s
Lift velocity	200 mm/s
Lowering velocity	200 mm/s



FIG 2-61

UP/DOWN PARAMETERS CUTOUT TOOL

2. Set the same value of velocity as the one that will be used in the job. Leave the lift and lowering velocity at 200 mm. The velocity can be set to a lower value if the material that needs to be cut is very tough. Calibrate the Up position by clicking Up position in Axis Control or press Up on the remote. Press the down arrow (computer or remote) until the tip of the knife is about 4 – 5 mm above the material. Then press apply (on computer) or A (on remote).

3. Calibrate the down position. To calibrate the down position, click Down position in Axis Control or press Down on the remote. It is best to first move the knife next to the media with the right arrow (computer or remote). Otherwise it is not possible to see how deep the knife is set. Then press the down arrow (computer or remote) until the tip of the knife just touches the grey mat. A white sheet can be used to see exactly when it touches the mat. The sheet can be put behind the knife for a visual check or under the knife to check physically. Then press Test. The flatbed will now cut out a square. Check if the knife is set deep enough. If not, adjust the down position a bit more. Do not forget to first click Apply before another parameter is chosen. Otherwise the value is not saved.



ATTENTION: Make sure the down position is not set too deep. Otherwise the mat will wear down fast. Therefore, it is recommended to do following. If the correct down position is found, set the down position two steps higher and do the test again. If the knife does not cut deep enough, set the down value again to what it was before. If it still cuts completely through the material, this means the down position was set too low and needs to be changed.



ATTENTION: Make sure the test is done at the same speed at which the job will be cut. Otherwise it is possible the knife depth will not be set correctly and the cutting lines will look like a dashed cutting line at the rear side of the material. The maximum speed for the oscillating tool has been limited to 300 mm/s. Also the knife frequency needs to be set correctly before the knife depth test is done. It is recommended to use a standard frequency for the EOT. This will normally lead to good quality and is less stressful for the tool, so it does not wear down that fast.



ATTENTION: The rest of the calibration is the calibration of the knife parameters. These calibrations may be too hard on the knives if the material is too thick. Therefore, it is sometimes recommended to do the knife calibration test (origin, lateral and longitudinal) with a reduced knife depth. Set the knife depth correctly afterwards. The recommended knife depth is then usually around 1-3 mm deep in the material.

4. After this, the knife parameters need to be set. This can't be done with the remote. In Axis Control click the parameter that needs to be checked or set. Click Test. Check the pattern that was cut out. In Axis Control a window opens with a drawing of the pattern that was cut out. In this window click the place where the correct pattern was cut out. The test will differ according to the parameter that was chosen (highlighted in blue).

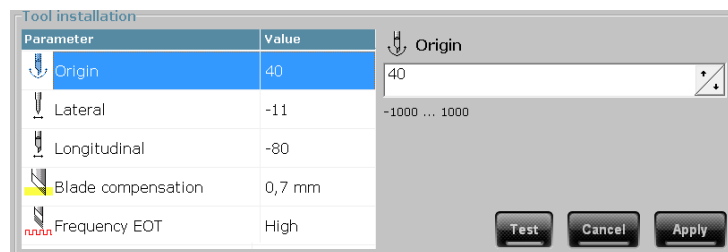

FIG 2-62
SETTING KNIFE PARAMETERS EOT

Setting the origin parameter

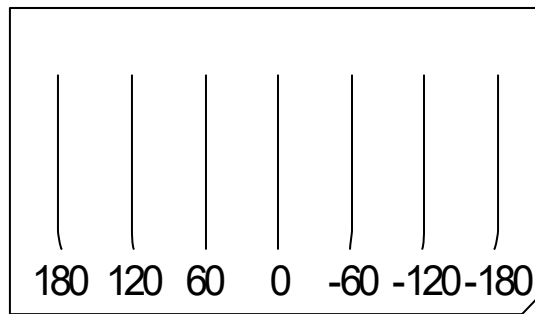
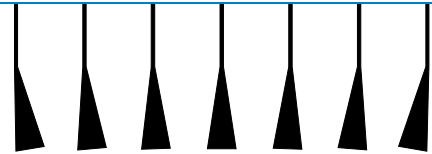

FIG 2-63
ORIGIN PATTERN TEST FOR EOT

The cutter will cut out a test pattern and a window will pop up in Axis Control. The origin test looks like the pattern above. Look for the straightest line between the 7 lines. When the origin is not correct, then the knife is pushed in the media under an angle (in reference to the cut direction) and dragged straight into the cut direction. This means the beginning of the line has to be inspected. The figure above contains values, the cut out pattern doesn't. These values are different from the current value. Check for the straightest line and select the according one in the popup window. The extended cut out test goes from +180 over 0 to -180. The values are indicative, which means the user can adjust the value manually, should it be clear that the correct pattern is probably just in between two cut out patterns.



NOTE: With some materials it is necessary to use a magnifying glass to check the start of the line. The start will then look something like the picture on the right.



Setting the lateral parameter

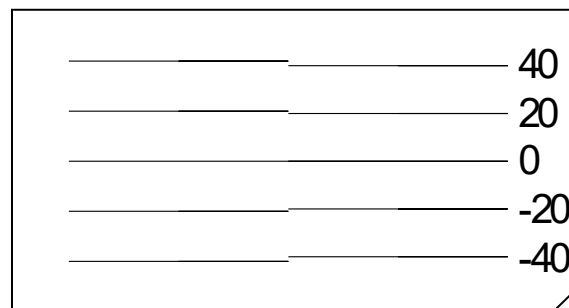

FIG 2-64
LATERAL PATTERN TEST FOR EOT

The horizontal lines are cut out in two parts. Each line is cut from the middle to the side. If the lateral parameter is not set correctly, the lines do not meet in the middle. They are shifted. The figure above contains values, the cut out pattern doesn't. These values in the picture are different from the current value. Check for the line where there is no shift in the middle and select the according one in the popup window. The values are indicative, which means the user can adjust the value manually should it be clear that the correct pattern is probably just in between two cut out patterns.

Setting the longitudinal parameter

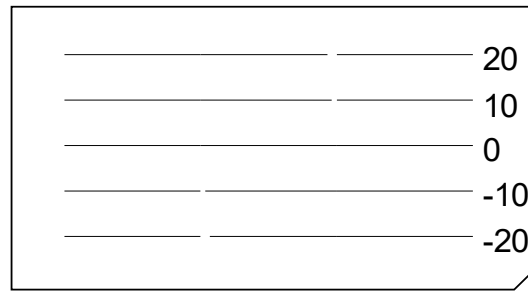

FIG 2-65
LONGITUDINAL PATTERN TEST FOR EOT

The horizontal cutting lines should meet. Check which pattern comes closest to the correct pattern and then choose this one in Axis Control. The values in the figure above are not cut out. They are indicative, so the user can adjust the value manually should it be clear that the correct pattern is probably just in between two cut out patterns.

There is a second long test (shown in the figure below). Just hold down the Ctrl key while clicking the test button to start this test.

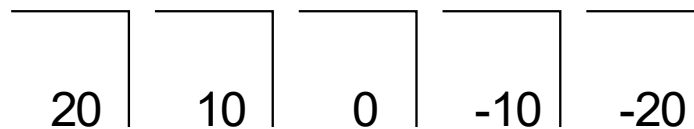

FIG 2-66
ORIGIN PATTERN TEST FOR THE KISS CUTTING KNIFE

The cutter will cut out a test pattern and a window will pop up in Axis Control. The special origin test looks like the pattern above. With the single edge knife and the heavy-duty knife, look for the pattern where the horizontal line starts flushing with the vertical line. With the double edge knife, look for the pattern where the overcut in the corner is the same on both lines. The values may differ, depending on the firmware revision. However, the procedure is the same. Just click the most correct pattern.

Setting the blade compensation parameter

This is only necessary for materials of more than 2 to 3 mm thick. When thick media is cut, the knife will bend in the corners. As a result the cutting line on top of the media will be shifted a little bit in reference to the cutting line in the bottom of the media. The smaller the curve, the tougher and the thicker the media and the more this will be visible. To compensate this, there is the parameter Blade compensation. This parameter anticipates the knife orientation (the distance is set with this parameter), so that the top cut and the bottom cut are both closest to the ideal cutting line. However, this parameter can never compensate a 100 % due to the physical limitations of the knife and cutting process. Therefore, it is also recommended to transform small curves in the design into corners or polygons (depending on the design itself). To set the parameter, do the following. Click Blade compensation (it becomes blue highlighted). Click Test. The cutter will cut out a small square with rounded corners. Fill in a value and do the test. A good starting value is half the width of the knife. This is a trial-and-error test. Values between 0 and 1 mm are not used.

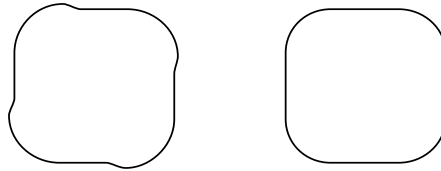

FIG 2-67

TEST PATTERN CUTOUT TOOL BLADE COMPENSATION PARAMETER

The picture above shows two possible results of the blade compensation test. In the left pattern the blade compensation value is too low. In the right pattern it is set correctly. If the blade compensation is set too high, the result is more deformed and distorted. Therefore, it is best that this test is done from a value, which is too low, to the correct value.





ATTENTION: Do not use small curves in the design and do not use hard material. This will cause the knife to break.



ATTENTION: Failing to set the knife parameters correctly will result in poor cut quality and shorter lifetime of the blades.

2.5.1.4 Calibration of the creasing tool



1. Click  if the tool just has been changed. Axis Control will give a reminder in order not to forget to calibrate the tool before using it. Click  to acknowledge. Check if the origin



of the loaded media is still set correctly. If not, adjust and click . If Axis Control is not automatically selecting the correct module to calibrate, correct this by clicking on the picture of the module. If the remote is used to choose the module, press several times on the module until the correct one is chosen. The lights on the remote show which module is currently chosen to calibrate. The left light is module 1; the light next to that is module 2 and the second last light in the row is module 3.

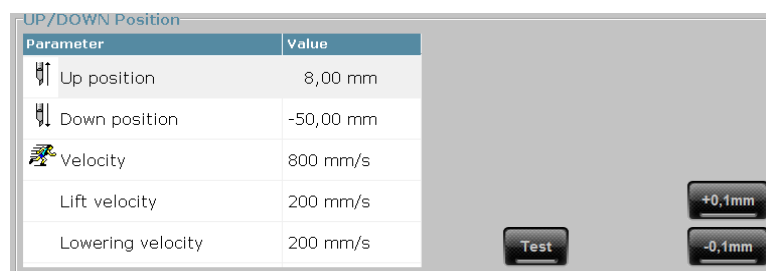

FIG 2-68

SETTINGS OF CREASING PARAMETERS

2. Set the same value of velocity as the one that will be used in the job (recommended speed for creasing tool is 800mm/s or more). Leave the lift and lowering velocity at 200 mm. The lowering velocity can be set to a lower value if the material, that needs to be creased, is very tough. Then calibrate the up position by clicking on 'Up position' in Axis Control or press 'Up' on the remote. Then press the down arrow (computer or remote) until the tip of the knife is about 4 – 5 mm above the material. Press 'Apply' (on computer) or 'A' (on remote).

3. Then calibrate the down position. To calibrate the down position click 'Down position' in Axis Control or press 'Down' on the remote. Then press the down arrow (computer or remote) until the creasing wheel pushes in the material. Press Test. The flatbed makes a pattern. Check if the creasing wheel is set deep enough. If not, adjust the down position a bit more. Do not forget to first click 'Apply' before another parameter is chosen to change. Otherwise the value is not saved. The pattern consists out of an array of horizontal lines and vertical lines.
4. Certain materials need a different depth setting in the X and Y axis. This can then be adjusted through the flute direction parameter in combination with the down position offset parameter. The extra parameters flute direction and down position offset are only used for corrugated media. For none corrugated media set Flute direction to None and Down position offset to 0.
5. To set the down position, click 'Down position' in Axis Control or press 'Down' on the remote. Then press the down arrow (computer or remote) until the creasing wheel pushes in the material. Press Test. The flatbed makes a pattern. Check if the creasing wheel is set deep enough. If not, adjust the down position a bit more. The pattern consists out of an array of horizontal lines and vertical lines.

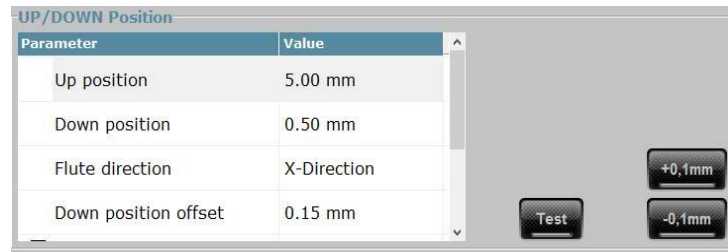
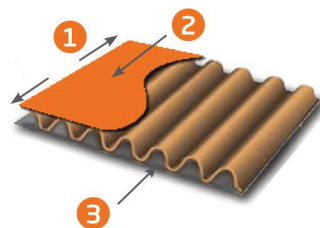

FIG 2-69
SETTINGS OF CREASING DEPTH PARAMETERS

6. If the media is corrugated, then the creasing depth will be too much in one direction (flute direction). If so, then set the flute direction correctly and set an offset for this direction. Then do the depth test again. Adjust the Down position offset, if necessary.



1. Flute direction
2. Top liner (outside)
3. Bottom liner (inside)

FIG 2-70
FLUTE DIRECTION CORRUGATED CARDBOARD

7. First set the depth with the down position parameter. Then set the flute direction. Set the down position offset and do a test. Adjust, if necessary. Only one direction will be corrected (the direction where the creasing wheel is set too deep).
8. Finally check the lateral parameter (the other tool parameters are not that critical and usually they do not need to be adjusted).

2.5.1.5 Calibration of the corrugated tool

The cutting depth of the corrugated tool is mechanically controlled by the pressure and the amount that the knife protrudes between the two wheels. The calibration of the tool consists out of two parts. First the knife itself is calibrated (initial depth and other knife parameters) then the actual cutting depth is set by doing small tests on the actual material because the final setting is media dependent.

To calibrate the corrugated tool, install the tool and turn the wheels to the maximum up position so the knife is completely visible (silver coloured ring – blue arrow).





FIG 2-71
SETTING OF CREASING DEPTH PARAMETERS

Then calibrate the knife as you would calibrate the Cutout knife (see section 2.5.1.2). Finally, a test needs to be done with the actual media that is going to be cut. Since the amount the knife protrudes is set by turning on the silver-coloured ring, it needs to be set/checked each time a job is started. A possible solution to avoid this would be to have several tools for several media.

With very heavy cardboard it is possible that the knife depth needs to be adjusted to get through the media.

2.5.1.6 Calibration of the V-cut tool

1. Click  if the tool just has been changed. Axis Control will give a reminder in order not to forget to calibrate the tool before using it. Click  to acknowledge.



ATTENTION: When a V-cut tool is installed, the machine resets the media size and origin automatically. The maximum area is reduced by 80 mm (40 mm at each border).



ATTENTION: When the knife depth of a V-cut tool is set, the knife moves straight down. This means that there can be no material underneath the knife when the down position is set. So make sure the loaded media (for calibrating) is at least 60 to 70 mm to the left of the origin (origin when cutting without V-Cut tool).



NOTE: We recommend using material that is 1-2mm thick when calibrating the V-cut tool.



- Click . If Axis Control is not selecting the correct module to calibrate automatically, correct it by clicking on the picture of the module. If the remote is used to choose the module, press several times on the module until the correct one is chosen. The lights on the remote show which module is currently chosen to calibrate. The left light is module 1, the light next to that is module 2 and the second last light in the row is module 3.

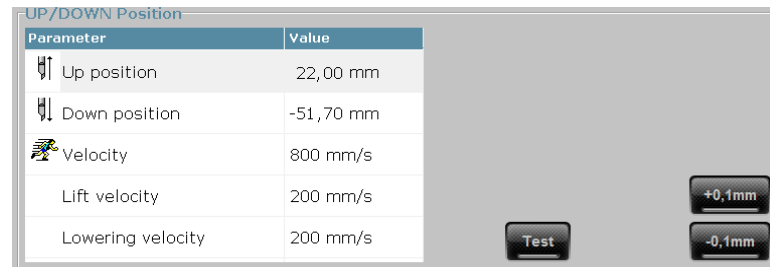

FIG 2-72
UP/DOWN PARAMETERS V-CUT

- The first parameter to calibrate is the up position. To calibrate the up position click 'Up position' in Axis Control or press 'Up' on the remote. Then press the down arrow (computer or remote) until the knife is about 4 – 5 mm above the material. Press 'Apply' (on computer) or A (on remote).
- The calibration of the down position is done in several steps. First, the knife parameters need to be set with reduced knife depth. Afterwards, the knife depth can be set correctly. The knife depth for setting the origin is a couple of mm, the knife depth for the lateral and longitudinal setting is set this way the knife just scratches the surface of the material. To calibrate the down position, click 'Down position' in Axis Control or press 'Down' on the remote. Press the down arrow (computer or remote) until the knife pushes a little bit in the material. Then press 'Test'. The machine cuts a pattern. If the lateral parameter is already set correctly, one line in the middle will be cut twice. If the lateral parameter is set correctly, there will be a little distance between the two lines in the middle.

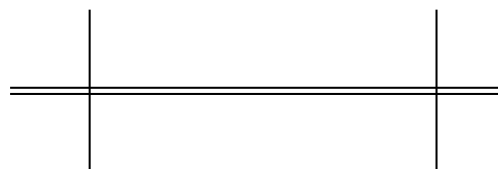

FIG 2-73
TEST PATTERN KNIFE DEPTH TEST V-CUT

- The knife parameters can't be set with the remote. In Axis Control click the parameter that needs to be checked or set. Then click 'Test'. The test will differ according to the parameter that was chosen (highlighted in blue).

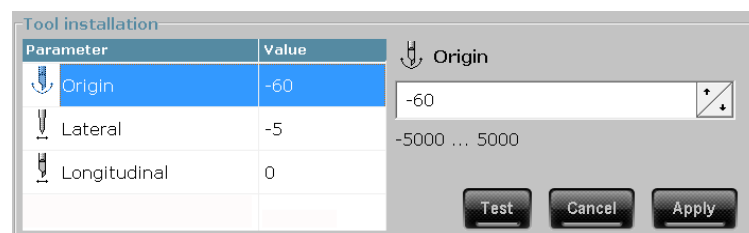

FIG 2-74
SETTING KNIFE PARAMETERS V-CUT

Setting the origin parameter

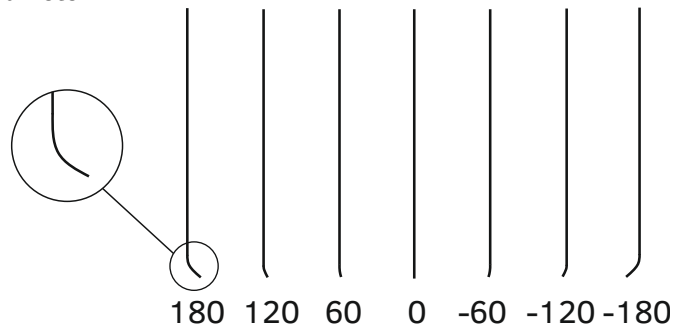

FIG 2-75

ORIGIN PATTERN TEST FOR V-CUT KNIFE

The cutter will cut out a test pattern with a chipped bottom right corner as reference point. A window will pop up in Axis Control. The origin test looks like the pattern above. Turn over the test pattern and check it from the backside. Look for the straightest line between the 7 lines. When the origin is not correct, then the knife is pushed in the media under an angle (in reference to the cut direction) and then dragged straight into the cut direction. This means the beginning (bottom part) of the line has to be inspected. The figure above contains values; the cut-out pattern doesn't. These values are different from the current value. Check for the straightest line and select the according one in the popup window. Bear in mind that you are inspecting the pattern from the backside while the popup window in Axis Control shows the frontside. The chipped bottom right corner helps with orientation. The extended cut out test goes from +180 over 0 to -180. The values are indicative, so the user can adjust the value manually should it show the correct pattern is probably just in between two cut-out patterns.

Setting the lateral parameter

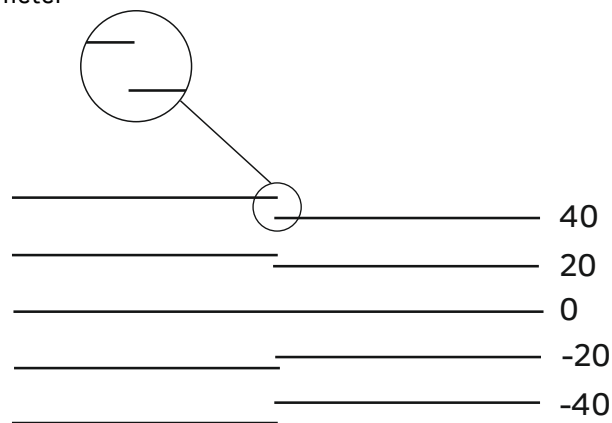

FIG 2-76

LATERAL PATTERN TEST FOR V-CUT KNIFE

The horizontal lines are cut out in two parts. Each line is cut from the middle to the side. Turn over the test pattern and check it from the backside. If the lateral parameter is not set correctly, the lines do not meet in the middle. They will be shifted. The figure above contains values; the cut out pattern doesn't. These values in the picture are different from the current value. Check for the line without shift in the middle and select the according one in the popup window. Bear in mind that you are inspecting the pattern from the backside while the popup window in Axis Control shows the frontside. The chipped bottom right corner helps with orientation. The values are indicative, so the user can adjust the value manually should it be clear that the correct pattern is probably just in between two cut-out patterns.

Setting the longitudinal parameter

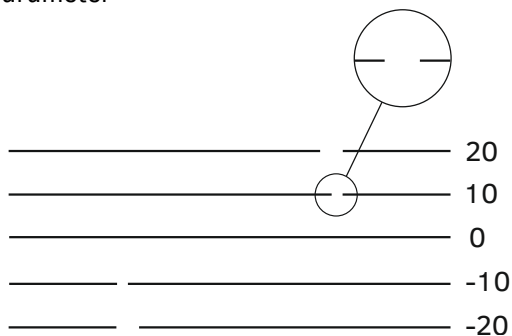

FIG 2-77
LONGITUDINAL PATTERN TEST FOR V-CUT KNIFE

Turn over the test pattern and check it from the backside. The horizontal cut lines should meet. Check which pattern comes closest to the correct pattern and then choose this one in Axis Control. Bear in mind that you are inspecting the pattern from the backside while the popup window in Axis Control shows the frontside. The chipped bottom right corner helps with orientation. The values in the figure above are not cut out. They are indicative, so the user can adjust the value manually, should it show the correct pattern is probably just in between two cut-out patterns. Press apply or A on the remote to leave the knife parameter tests.

- Finally, the down position will have to be set. Click 'Down Position' in Axis Control or press 'Down' on the remote. First press the right arrow key, so the knife is not situated above the media anymore. If the knife cannot be set next to the media, reload the media to enable this. Press the down arrow (computer or remote) until the knife depth is approximately correct (usually a little bit above the table surface). Press Test. The machine cuts a pattern. Check if the knife depth is set correctly. If this is not the case, adjust it.



ATTENTION: The V-Cut tool is a tool that is not easy to calibrate. The only way to check if the tool has been calibrated is to perform a V-Cut with the cutting software. After a test has been cut out, check the V-shaped part that comes out of the material and check if the bend is correct. Usually, the bend gets better if the lateral gap is set at 20 or 30.

To start the test described above, click on lateral gap and hold down the control key while clicking on the test button.





WARNING: It is mandatory to move the knife to the right of the media before doing a depth test. If this is not done, then the knife tip will be destroyed if the knife depth is adjusted.

The knife depth may need to be adjusted, so the knife scratches scarcely in the bottom liner and in case the cut out part is not completely loose after the cut. Usually, the angle of the bend improves if the lateral gap is set to 20 or 30.

2.5.1.7 Calibration of the bevel-cut knife



1. Click  if the tool just has been changed. Axis Control will give a reminder in order not to forget to calibrate the tool before using it. Click  to acknowledge.



ATTENTION: When a bevel-cut tool is installed, the machine resets the media size and origin automatically. The maximum area is reduced by 80 mm (40 mm at each border).



ATTENTION: When the knife depth of a bevel-cut tool is set, the knife moves straight down. This means that there can be no material underneath the knife when the down position is set. So, make sure the loaded media (for calibrating) is at least 60 to 70 mm to the left of the origin (origin when cutting without bevel-cut tool).



NOTE: We recommend using material that is 1-2mm thick when calibrating the bevel-cut tool.



2. Click . If Axis Control is not selecting the correct module to calibrate automatically, correct it by clicking on the picture of the module. If the remote is used to choose the module, press several times on the module until the correct one is chosen. The lights on the remote show which module is currently chosen to calibrate. The left light is module 1, the light next to that is module 2 and the second last light in the row is module 3.

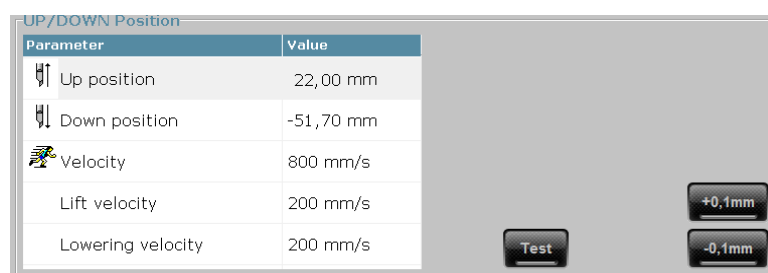

FIG 2-78
UP/DOWN PARAMETERS BEVEL-CUT

3. The first parameter to calibrate is the up position. To calibrate the up position, click 'Up position' in Axis Control or press 'Up' on the remote. Then press the down arrow (computer or remote) until the knife is about 4 – 5 mm above the material. Press 'Apply' (on computer) or A (on remote).

4. The calibration of the down position is done in several steps. First, the knife parameters need to be set with reduced knife depth. Afterwards, the knife depth can be set correctly. The knife depth for setting the origin is a couple of mm, the knife depth for the lateral and longitudinal setting is set this way the knife just scratches the surface of the material. To calibrate the down position, click 'Down position' in Axis Control or press 'Down' on the remote. Press the down arrow (computer or remote) until the knife pushes a little bit in the material. Then press 'Test'. The machine cuts a pattern. If the lateral parameter is already set correctly, one line in the middle will be cut twice. If the lateral parameter is set correctly, there will be a little distance between the two lines in the middle.

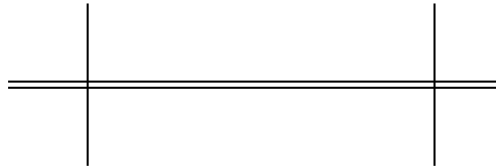

FIG 2-79
TEST PATTERN KNIFE DEPTH TEST BEVEL-CUT

5. The knife parameters can't be set with the remote. In Axis Control click the parameter that needs to be checked or set. Then click 'Test'. The test will differ according to the parameter that was chosen (highlighted in blue).

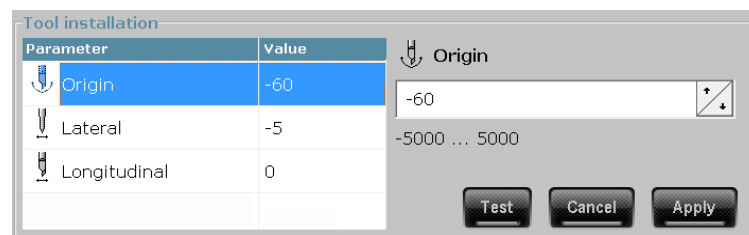

FIG 2-80
SETTING KNIFE PARAMETERS BEVEL-CUT

Setting the origin parameter

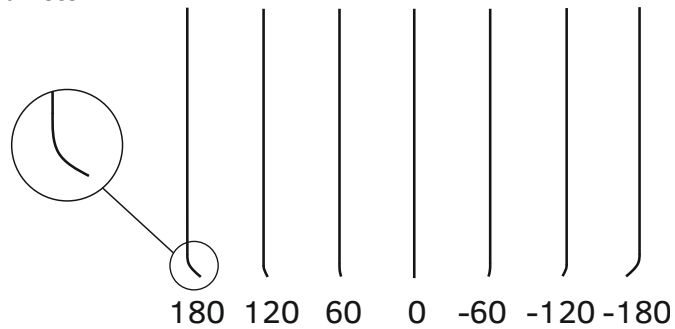

FIG 2-81

ORIGIN PATTERN TEST FOR BEVEL-CUT KNIFE

The cutter will cut out a test pattern with a chipped bottom right corner as reference point. A window will pop up in Axis Control. The origin test looks like the pattern above. Turn over the test pattern and check it from the backside. Look for the straightest line between the 7 lines. When the origin is not correct, then the knife is pushed in the media under an angle (in reference to the cut direction) and then dragged straight into the cut direction. This means the beginning (bottom part) of the line has to be inspected. The figure above contains values; the cut-out pattern doesn't. These values are different from the current value. Check for the straightest line and select the according one in the popup window. Bear in mind that you are inspecting the pattern from the backside while the popup window in Axis Control shows the frontside. The chipped bottom right corner helps with orientation. The extended cut out test goes from +180 over 0 to -180. The values are indicative, so the user can adjust the value manually should it show the correct pattern is probably just in between two cut-out patterns.

Setting the lateral parameter

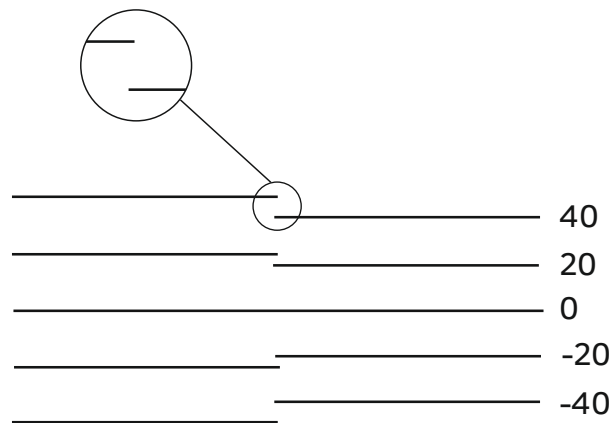

FIG 2-82
LATERAL PATTERN TEST FOR BEVEL-CUT KNIFE

The horizontal lines are cut out in two parts. Each line is cut from the middle to the side. Turn over the test pattern and check it from the backside. If the lateral parameter is not set correctly, the lines do not meet in the middle. They will be shifted. The figure above contains values; the cut out pattern doesn't. These values in the picture are different from the current value. Check for the line without shift in the middle and select the according one in the popup window. Bear in mind that you are inspecting the pattern from the backside while the popup window in Axis Control shows the frontside. The chipped bottom right corner helps with orientation. The values are indicative, so the user can adjust the value manually should it be clear that the correct pattern is probably just in between two cut-out patterns.

Setting the longitudinal parameter

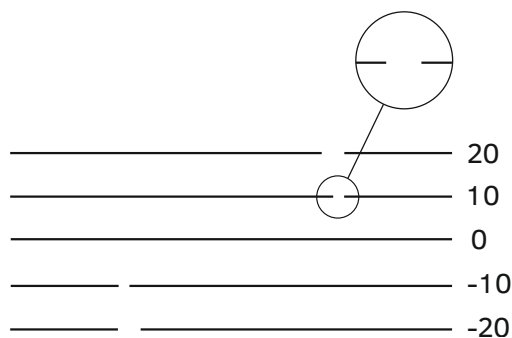

FIG 2-83
LONGITUDINAL PATTERN TEST FOR BEVEL-CUT KNIFE

Turn over the test pattern and check it from the backside. The horizontal cut lines should meet. Check which pattern comes closest to the correct pattern and then choose this one in Axis Control. Bear in mind that you are inspecting the pattern from the backside while the popup window in Axis Control shows the frontside. The chipped bottom right corner helps with orientation. The values in the figure above are not cut out. They are indicative, so the user can adjust the value manually, should it show the correct pattern is probably just in between two cut-out patterns. Press apply or A on the remote to leave the knife parameter tests.

6. Finally, the down position will have to be set. Click 'Down Position' in Axis Control or press 'Down' on the remote. First press the right arrow key, so the knife is not situated above the media anymore. If the knife cannot be set next to the media, reload the media to enable this. Press the down arrow (computer or remote) until the knife depth is approximately correct (usually a little bit above the table surface). Press Test. The machine cuts a pattern. Check if the knife depth is set correctly. If this is not the case, adjust it.



ATTENTION: The bevel-cut tool is a tool that is not easy to calibrate. The only way to check if the tool has been calibrated is to perform a bevel-cut with the cutting software. After a test has been cut out, check the bevel-shaped part that comes out of the material and check if the bend is correct. Usually, the bend gets better if the lateral gap is set at 20 or 30.

To start the test described above, click on lateral gap and hold down the control key while clicking on the test button.



WARNING: It is mandatory to move the knife to the right of the media before doing a depth test. If this is not done, then the knife tip will be destroyed if the knife depth is adjusted.

The knife depth may need to be adjusted, so the knife scratches scarcely in the bottom liner and in case the cut-out part is not completely loose after the cut. Usually, the angle of the bend improves if the lateral gap is set to 20 or 30.

2.5.1.8 Calibration of the perforating knife



ATTENTION: It is highly discouraged to use the perforating tool on a machine without an ADC.

Apart from the depth, the rest of the parameters of the perforating tools are very difficult to calibrate without the ADC. However the parameters can still be adjusted if needed.

To adjust the depth do the following:

1. Check if the origin of the loaded media is still set correctly. If not, adjust and click . If Axis Control is not automatically selecting the correct module to calibrate, correct this by clicking on the picture of the module. If the remote is used to choose the module, press several times on the module until the correct one is chosen. The lights on the remote show which module is currently chosen to calibrate. The left light is module 1; the light next to that is module 2 and the second last light in the row is module 3.

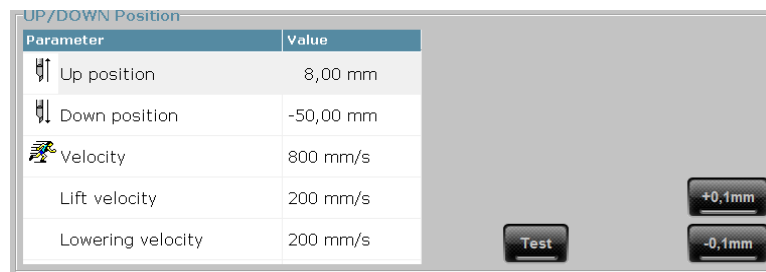



FIG 2-84
ADJUSTING KNIFE DEPTH PERFORATING KNIFE

2. click 'Down position' in Axis Control or press 'Down' on the remote. Press Test. The flatbed makes a pattern. Check if the perforating knife is set deep enough. If not, adjust the down position a bit more. The pattern consists out of an array of horizontal lines and vertical lines.

2.5.1.9 Calibration of the POT

1. Axis Control will give a reminder in order not to forget to calibrate the tool before using it. Click  to acknowledge. Load the media. Make sure there is a bit of space between the origin (y-axis) of the table and the material. (Use 'line drawn' to mark the origin as described in section 3.1.6).



2. Click . If Axis Control is not selecting the correct module to calibrate automatically, correct it by clicking on the picture of the module. If the remote is used to choose the module, press several times on the module until the correct one is chosen. The lights on the remote show which module is currently chosen to calibrate (M1, M2 or M3, counting from the left).
3. The POT tool cannot always be calibrated in the media. It will be cut (e.g. origin cannot be set in foam materials). The best material for complete calibration is a rigid material of a couple of mm. On the other hand if the material is too thick, then some tests cannot be done at full depth.
4. The first parameter to calibrate is the up position. To calibrate the up position, click 'Up position' in Axis Control or press 'Up' on the remote. Then press the down arrow (computer or remote) until the knife just touches the material. Move the knife left - right to check if the tip of the bit scratches the media. Set the height so it just scratches the media. Look at the value on screen and memorize it. Now set the value about 4 – 5 mm lower. Then press 'Apply' (on computer) or 'A' (on remote).
5. To calibrate the down position, click 'Down position' in Axis Control or press 'Down' on the remote. If the material is thicker than 4 mm, then set the down position first at a value 3 mm higher than the memorized value from the previous step. The final depth calibration can then be done after the knife parameters have been set.



ATTENTION: Make sure that the test is done at the same speed at which the job will be cut. Otherwise it is possible that the knife depth will not be set correctly and that the cutting lines will look like a dashed cutting line at the rear side of the material.

6. The setting of the knife parameters can't be done with the remote. Click the parameter that needs to be checked or set in Axis Control. Then click 'Test'. Check the pattern that was cut out. In Axis Control a window opens with a drawing of the pattern that was cut out. Click in this window on the place where the correct pattern was cut out. The test will differ according to the parameter that was chosen (highlighted in blue).

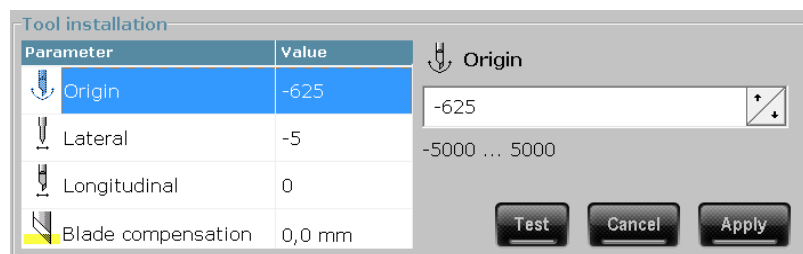

FIG 2-85
SETTING KNIFE PARAMETERS EOT

Setting the origin parameter

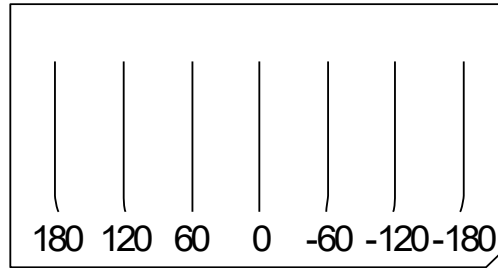
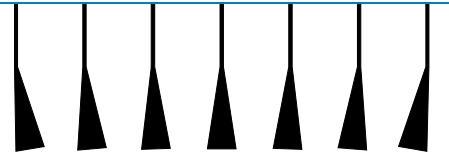

FIG 2-86
ORIGIN PATTERN TEST FOR EOT

The cutter will cut out a test pattern and a window will pop up in Axis Control. The origin test looks like the pattern above. Look for the straightest line between the 7 lines. When the origin is not correct, then the knife is pushed in the media under an angle (in reference to the cut direction) and then dragged straight in the cut direction. This means the beginning of the line needs to be inspected. The figure above contains values; the cut out pattern doesn't. These values are different from the current value. Check for the straightest line and select the according one in the popup window. The extended cut out test goes from +180 over 0 to -180. The values are indicative, so the user can adjust the value manually should it be clear that the correct pattern is probably just in between two cut out patterns.



NOTE: With some materials it is necessary to use a magnifying glass to check the start of the line. The start will then look something like the picture on the right.



Setting the lateral parameter

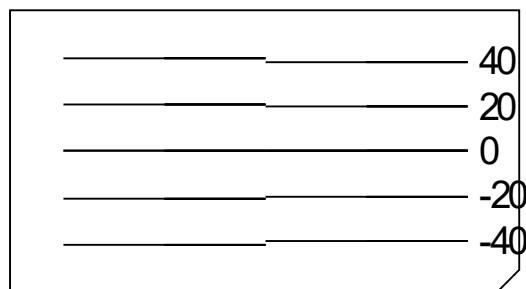

FIG 2-87
LATERAL PATTERN TEST FOR EOT

The horizontal lines are cut out in two parts. Each line is cut from the middle to the side. If the lateral parameter is not set correctly, then the lines do not meet in the middle. They will be shifted. The figure above contains values; the cut out pattern doesn't. These values in the picture are different from the current value. Check for the line without shift in the middle and select the according one in the popup window. The values are indicative, so the user can adjust the value manually should it be clear that the correct pattern is probably just in between two cut out patterns.

Setting the longitudinal parameter

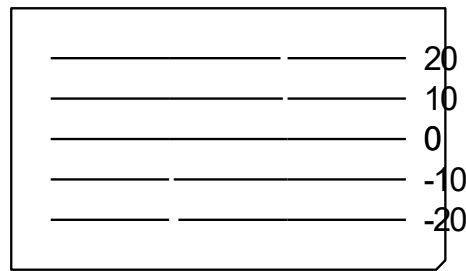

FIG 2-88
LONGITUDINAL PATTERN TEST FOR EOT

The horizontal cut lines should meet. Check which pattern comes closest to the correct pattern and then choose this one in Axis Control. The values in the figure above are not cut out. They are indicative, so the user can adjust the value manually should it be clear that the correct pattern is probably just in between two cut out patterns.

Setting the blade compensation parameter

A shortcut will be used for setting the knife compensation parameter after the correct depth is set.

Now the correct down position can be set. Click 'Down position' in Axis Control or press 'Down' on the remote. First press the right arrow, so the router bit is between the material and the Y-axis origin. Then press on the down arrow (computer or remote) until the value is the value that was memorized during the calibration of the up position plus the thickness of the media. Press test to cut out a square. Adjust with the up/down arrow, if necessary. And check again until the desired depth is set (use steps of 0.3 mm).



ATTENTION: The stroke and frequency of the POT depend on the load. This means that increasing the cutting depth by a certain amount of tenths of a mm can result in an actual cutting depth that is a bit more than the raised couple of tenths of a mm. Therefore, it is recommended to use a mat underneath the media if the media allows it.

There is a second long test (shown in the figure below). Just hold down the Ctrl key while clicking the test button to start this test.

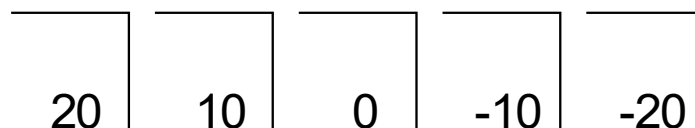

FIG 2-89
ORIGIN PATTERN TEST FOR THE KISS CUTTING KNIFE

The cutter will cut out a test pattern and a window will pop up in Axis Control. The special origin test looks like the pattern above. With the single edge knife and the heavy duty knife, look for the pattern where the horizontal line starts flushing with the vertical line. With the double edge knife, look for the pattern where the overcut in the corner is the same on both lines. The values may differ, depending on the firmware revision. However, the procedure is the same. Click the most correct pattern.

Setting the blade compensation is done as follows: Do the test with different values and then set it to the value which gave the best result.

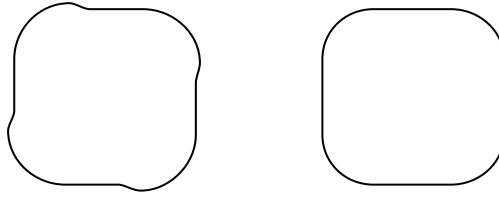

FIG 2-90
TEST PATTERN CUTOUT TOOL BLADE COMPENSATION PARAMETER

The picture above shows two possible results of the blade compensation test. In the left pattern the blade compensation value is too low. In the right pattern it is set correctly. If the blade compensation is set too high, then the result is more deformed and distorted.



ATTENTION: Do not use small curves in the design and do not use hard material. This will cause the knife to break.



ATTENTION: Failing to set the knife parameters correctly will result in poor cut quality and shorter life time of the blades.

2.5.1.10 Calibration of the high torque rotary module

1. If another module was previously installed in that same place, Axis Control will give a reminder that you need to check the knife depth first. Click  to acknowledge if this is the case.



ATTENTION: If the origin is not set correctly, the knife will seriously damage the conveyor belt.



NOTE: When the module is installed for the first time, or when there is doubt whether the origin is set correctly or not, do the depth and origin setting on a piece of paper on a protection mat or in the top half of corrugated cardboard (1 – 3 mm). When the origin is set correctly, do a second knife depth setting on the material that will actually be used.

2. Check if the origin of the loaded media is still set correctly, if not, adjust it and click . If Axis Control is not automatically selecting the rotary module, click the picture of the rotary module. If the remote is used to choose the module, press several times on the module until the correct one is chosen. The lights on the remote show which module is currently chosen to calibrate. The third LED should be lit up. First the up/down parameters need to be set.

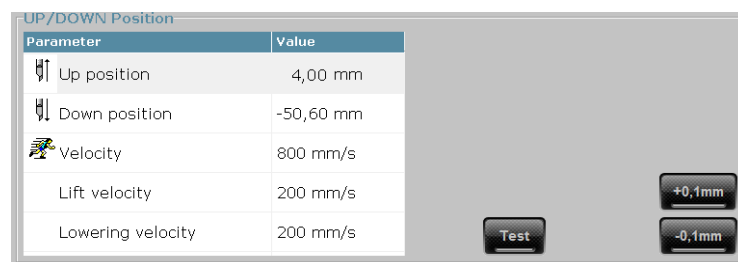

FIG 2-91

UP/DOWN PARAMETERS ROTARY MODULE

3. Set the same value of velocity as the one that will be used in the job. Leave the lift and lowering velocity at 200 mm. Calibrate the up position by clicking 'Up position' in Axis Control or press 'Up' on the remote. Press the down arrow (computer or remote) until the tip of the knife is about 4 – 5 mm above the material. Press apply (on computer) or A (on remote).
4. Calibrate the down position. To calibrate the down position, click 'Down Position' in Axis Control or press 'Down' on the remote. It is best to first move the knife next to the media with the left arrow (computer or remote), otherwise it is not possible to see how deep the knife is set. Then press the down arrow (computer or remote) until the tip of the knife just touches the protection mat. A white sheet of paper can be used to see exactly where it touched the protection mat. If corrugated cardboard is used to set the origin, make sure the knife does not touch the conveyor. Press Test. The flatbed will now cut out a square. Check if the knife is set deep enough. If not, adjust the down position a bit more. Do not forget to first click Apply before another parameter is chosen. Otherwise the value is not saved.



ATTENTION: The final knife depth is not set correctly yet. This is just the knife depth setting for the origin and lateral test.

5. After this, the knife parameters need to be set. This can't be done with the remote. Click the parameter that needs to be checked or set in Axis Control. Then click Test. Check the pattern that was cut out. A window opens in Axis Control with a drawing of the pattern that was cut out. In this window click the place where the correct pattern was cut out. The test will differ according to the parameter that was chosen (highlighted in blue).

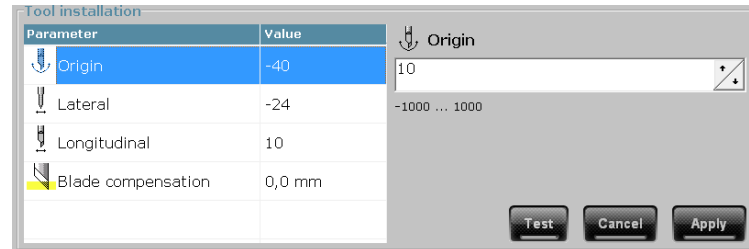

FIG 2-92
SETTING KNIFE PARAMETERS ROTARY MODULE

Setting the origin parameter.

The cutter will cut out a test pattern and a window will pop up in Axis Control. A wrong origin setting will damage the conveyor belt. This will be clear when you check the test pattern for errors. Due to the physical properties of the knife, the 'footprint' or mark the knife cuts in the material is a thin line. If the knife is moved forward at an angle (wrong origin) then this short line is dragged through the material, resulting in removing material and leaving a gouge afterwards. If that happens to the conveyor, it will be irreversibly damaged.

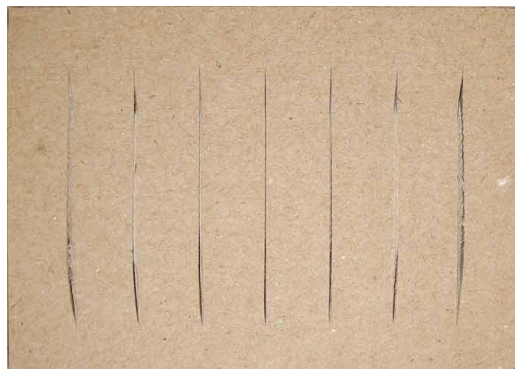

FIG 2-93
ORIGIN PATTERN TEST FOR THE ROTARY KNIFE

The origin test, cut in corrugated cardboard, looks like the pattern above. Look for the straightest line between the 7 lines. The extended cut-out test goes from +180 over 0 to -180. The values are indicative, so the user can adjust the value manually should it show the correct pattern is probably just in between two cut out patterns.



ATTENTION: Do not hesitate to choose values between two lines, adjust the value by hand and redo the origin test. A precise origin calibration results in a longer lifetime.

Setting the lateral parameter.

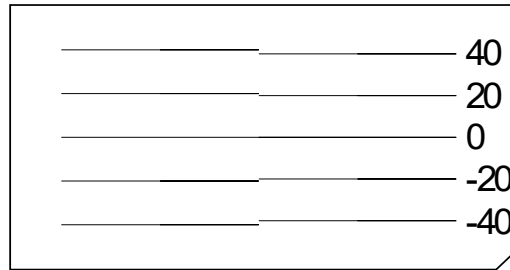

FIG 2-94
LATERAL PATTERN TEST FOR THE ROTARY KNIFE

The horizontal lines are cut out in two parts. Each line is cut from the middle to the side. If the lateral parameter is not set correctly, the lines do not meet in the middle but will be shifted. The figure contains values; the cut-out pattern doesn't. Check for the line where there is no shift in the middle and select the according one in the popup window. The values are indicative, so the user can adjust the value manually should it show the correct pattern is probably just in between two cut out patterns.

Setting the longitudinal parameter.

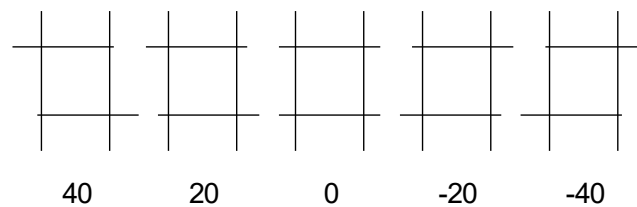

FIG 2-95
LONGITUDINAL PATTERN TEST FOR THE ROTARY KNIFE

Small squares are cut out. Check for the square where the horizontal overcuts are all the same and select the according one in the popup window. The values are indicative, so the user can adjust the value manually should it show the correct pattern is probably just in between two cut out patterns. If the longitudinal pattern is calibrated, then press apply.

6. Finally set the correct depth position. Put the material that will be cut on the conveyor Go again to 'Down position' and set the down position correctly in order to cut the material.





ATTENTION: Make sure the down position is not set too deep. Otherwise the conveyor will wear down fast. Therefore, it is recommended to do the following. If the correct down position is found, set the down position two steps higher and do the test again. If the knife does not cut deep enough, set the down value again to its previous value. If it still cuts completely through the material, this means the down position was set too low and needs to be changed.

2.5.1.11 Calibration of the router module

- *CHANGING ROUTER BIT AND DEPTH CALIBRATION*



1. Click  if the router bit was just changed. Axis Control will give a reminder in order not to forget to calibrate the tool before using it. Click  to acknowledge.
2. Load the media. Make sure there is a bit of space between the origin (y-axis) of the table and material. (Use 'draw origin' to mark the origin, as described in section 3.1.7.



3. Click . If Axis Control is not selecting the correct module to calibrate automatically, correct it by clicking the picture of the module. If the remote is used to choose the module, press several times on the module until the correct one is chosen. The lights on the remote show which module is currently chosen to calibrate. You need to choose module 3 for the miller.
4. The first parameter to calibrate is the up position. To calibrate the up position click 'Up position' in Axis Control or press 'Up' on the remote. Then press the down arrow (computer or remote) until the router bit just touches the material. Move the tool to the left and/or right to check if the tip of the bit scratches the media. Set the height this way it just scratches the media. Look at the value on screen and memorize it. Now set the value about 4 – 5 mm lower. Press apply (computer) or A (remote).
5. To calibrate the down position, click 'Down position' in Axis Control or press 'Down' on the remote. First press the right arrow this way the router bit is situated between the material and the Y-axis origin. Then press the down arrow (computer or remote) until the value is the same as the one that was memorized during the calibration of the up position plus the thickness of the media. Press test to route a square. Adjust with the up/down arrow, if necessary. Check again until the desired depth is set (use steps of 0.3 mm).



ATTENTION: Make sure that during this test the vacuum is not set too high (make sure the brush is set high enough and lower the vacuum strength as described in step 14, if necessary). If the vacuum is set too high, then the material can be lifted a bit, so an incorrect setting of the depth will be the result. The router is set at the correct depth if the pattern that is cut is clearly visible in the router mat (couple of tenths of a mm cut into the mat).

6. Once the correct down position is set, turn on the extractor height control handle until the brushes are situated just above the material (make sure the brushes do not touch the material. It should be situated 1 – 2 mm above the material, otherwise it creates too big a vacuum).

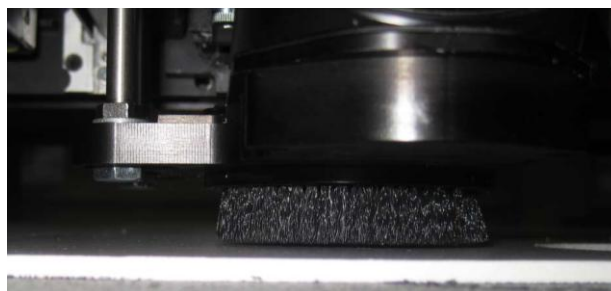

FIG 2-96
CORRECT HEIGHT EXTRACTOR BRUSH

7. Press Apply to store the values.
8. The strength of the extractor vacuum can be adjusted with a ring that can be turned this way a hole is uncovered or covered. If small parts are milled, this hole needs to be uncovered, otherwise the little parts may disappear in the vacuum cleaner.



FIG 2-97
RING TO SET THE VACUUM STRENGTH

- *ORIGIN CALIBRATION OF THE ROUTER MODULE*

The router module has another origin position in reference to the camera/positioning laser than the tangential module. This needs to be calibrated, otherwise the origin and media size setting will not be correct. This calibration is mandatory if the router will be used in combination with printed job and remarks and/or a tool in slot position 1. In order to calibrate the origin for the router, follow the below procedure.

1. Load the media, install the module and tool.



2. Click  and click the picture of the camera unit in the window.
3. Click slot 3. The machine will drill a hole in the media with the router.

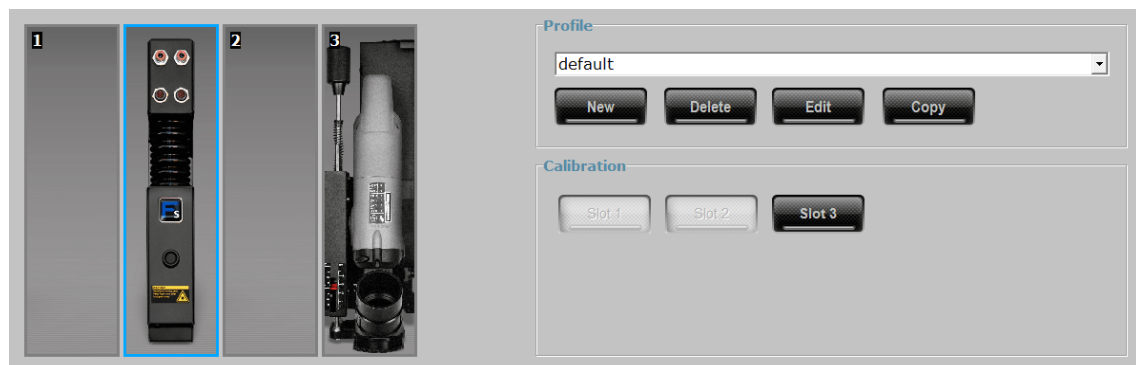

FIG 2-98
CALIBRATION DISTANCE ROUTER MODULE - CAMERA

4. There is the choice to calibrate automatically or to set the miller with the arrow keys in the center above the drilled hole.

2.5.2 Quick tool holder change without ADC option

The calibration parameters of the tools are very important to obtain a good cut quality. Some tools are more difficult to calibrate than others. Because of this, the table stores the tool parameters automatically.

So, if a previous installed tool is mounted in the machine, all settings will be restored from the internal memory. However, the warning about checking the knife depth will still appear. If a couple of rules and procedures are followed then changing most tools on an F Series table is easy and quick.

There are a couple of things that need to be taken in account before using the quick change procedures.

1. Label the modules and always mount them in the same position.
2. Make sure the tool has been calibrated completely in this module.
3. Always mount the tools in the same module, or calibrate each tool in each module.
4. The tool has not been changed in the tool holder.



ATTENTION: If there is more than 1 tangential module on the machine, the tools can be calibrated in each tangential module. It is not necessary then to hold record of where the tool was used. However, the tangential modules themselves always need to be mounted in the same slot.



ATTENTION: The main tool parameters (depth and knife parameters) are media independent. So the calibrations as described above can be done on scrap material. Only speed is material dependent.



WARNING: Be careful with the usage of the quick tool holder change procedures. When the normal complete calibration procedures are followed (see section 2.4. - 2.5.1.7) then it is almost impossible to cut in the conveyor belt. This is not guaranteed anymore, since the quick procedures use certain shortcuts and assumptions.

2.5.2.1 Quick tool change for the Kiss Cutting Knife

The Kiss Cutting Knife is used for thin materials. So the cutting depth usually depends on the physical depth settings and pressure setting on the tool holder itself.



1. Mount the tool in the module (use )

Axis Control will give a warning that the knife depth needs to be checked.



2. Click modules  to set/check the depth. If the user is confident that the knife was not changed in the tool holder, then a knife depth test can be performed. Click 'Down position' and click 'Test'. Check if the knife cuts deep enough.
3. If it doesn't cut deep enough set the down position correctly and check if the two bearings press on the media. Lower them, if necessary. Otherwise the depth will have to be adjusted with the pressure and depth of the knife on the tool holder itself. If the job includes relatively small curves, it is advised to do the test of the lateral parameter to check if the parameters need to be fine-tuned or not.

2.5.2.2 Quick tool change for the cutout tools

The cutout tool is usually used for cutting just through the material. So, if no extra underlay mat, for safety or other purpose, is used, the down position is the same for any kind of material.



1. Mount the tool in the module (use )

Axis Control will give a warning that the knife depth needs to be checked.



2. Click modules  to set/check the depth. First check the value for the down position and the up position. Subtract them from one another. The result should be at least 3 to 4 mm larger than the thickness of the loaded media. If not, the up position needs to be recalibrated.
3. If the user is confident that the knife was not changed in the tool holder, a knife depth test can be performed. Click the down position and click Test. Check the depth, adjust with the arrow up/down, if necessary. If the job will include relatively small curves, it is advised to do the test of the lateral parameter to check if the parameters need to be fine-tuned or not.

2.5.2.3 Quick tool change for the EOT

One of the specific properties of the EOT is that the knife depth depends on the cutting speed and the frequency of the tool. If the job uses media that requires speeds / frequencies, other than the saved values, the knife depth test needs to be done as described in section 2.5.1.3. The other parameters do not have to be recalibrated.



1. Mount the tool in the module (use )

Axis Control will give a warning that the knife depth needs to be checked.



2. Click modules  to set/check the depth. First check the value for the down position and the up position. Subtract them from one another. The result should be at least 3 to 4 mm larger than the thickness of the loaded media. If not, the up position needs to be recalibrated. If the result is higher than 5 mm, it is advised to recalibrate the up position. Otherwise too much time will be lost during the job.
3. If the user is confident that the knife was not changed in the tool holder, a knife depth test can be performed. Click the down position and click test. Check the depth. Adjust with the arrow up/down, if necessary. If the job includes relatively small curves, it is advised to do the test of the lateral parameter to check if the parameters need to be fine-tuned or not.

2.5.2.4 Quick tool change for the V-Cut

The V-Cut tool is a difficult tool to calibrate for the first time. However, the fixture, used to mount a knife in the tool holder, facilitates the calibration of the tool after a first calibration. The depth setting depends on the thickness of the coversheet of the media. If the loaded media has a totally different coversheet than the media used with the previous calibration of the V-Cut tool, the knife depth needs to be set, as described in section 2.5.1.5 from step 11 onwards. However, do not forget to check the up position first.



1. Mount the tool in the module (use )

Axis Control will give a warning that the knife depth needs to be checked.



2. Click modules  to set/check the depth. First check the value for the down position and the up position. Subtract them from one another. The result should be at least 3 to 4 mm larger than the thickness of the loaded media. If not, the up position needs to be recalibrated. If the result is higher than 5 mm, it is advised to recalibrate the up position. Otherwise too much time will be lost during the job.



WARNING: Be careful when doing a depth test with the V-Cut knife. If the knife depth test is done during the setting of the down parameter, the knife is set in the down position between tests. Therefore, the knife must be positioned next to the media before the test button is pushed, while setting/changing the down parameter.

3. Click the down position parameter. First click the right arrow until the knife tip is not situated above the media anymore. If this is not possible, leave the test and reposition the media a bit more to the left, so there is enough space to put the knife next to the media. Click Test. Checking the depth consists of two steps. First check if the part the knife cuts out is still slightly attached to the media. Tear it out and check if the cover sheet is scratched by the knife. If the knife did not scratch the media, the knife depth is not deep enough. See the standard knife depth calibration described in section 2.5.1.5. If the part that is cut out is not slightly attached to the media, go to the lateral parameter, decrease it by 20 and do the knife depth test again. Adjust the lateral parameter until it is set correctly.



NOTE: In order to avoid having to reset the knife each time to the right of the media, the knife depth test can also be done after clicking the up position parameter (after at least one knife depth test whilst in the down position setting).

2.5.2.5 Quick tool change for the POT

One of the specific characteristics of the POT is that the depth is not a fixed value and that it is very material dependent. Therefore, it is recommended to set the knife depth instead of just checking it. To set the knife depth, follow the procedure as described in section 2.5.1.6.

If the option Overcut Compensation Mode is used during the job, it is recommended to check the lateral parameter also.

2.5.2.6 Quick tool change for the creasing tools

The tool depth for a creasing wheel is very material dependent; it can even be job dependent. So no quick tool change procedure is recommended, unless exactly the same material is used with the same creasing tool. Sometimes a quick depth test can be sufficient.

2.5.2.7 Quick tool change for the router

Since it is recommended to clean the bit and collet each time before the router is mounted, there cannot be a quick tool change procedure. So, always follow the calibration procedure as described in section 2.5.1.11.

2.6 Quick depth adjust

If the knife depth has to be adjusted just a little bit (e.g. compensation for wear on the knife), the knife depth can be changed quickly.

2.6.1 General quick depth adjust





1. Click modules , then select the module, whose knife depth needs to be adjusted.

The chosen module has a blue rectangle around it and at the right side the buttons



for changing the depth are visible.

2. Click  to set the knife depth 0.1 mm deeper or click  to set the knife depth 0.1 mm less deep. The  button can be used to check the depth.





NOTE: The knife depth can only be altered 0.2 mm with this procedure. If a larger change is needed, the complete knife depth procedure needs to be followed.



2.6.2 Quick depth check/adjust during a job

The knife depth cannot be adjusted during a job. However, if a series of actions is done, the job can be saved.



1. Click  to pause the current job. Click  to abort the current job.

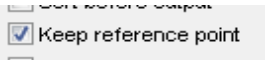

2. Click modules . Select the module, whose knife depth needs to be adjusted and click  once or twice to set the knife deeper.

3. Select the objects that need to be recut in Summa GoProduce (or use the same selection as before). Do not forget to check the box  Keep reference point, if needed.

2.7 Calibration of the drag module

Although the machine does not automatically recognize the tool, mounted in the drag module,

it is still necessary to click  to mount the pen or knife in the module. This to make sure the machine does not make any unexpected movement while the user is changing tools.

2.7.1 Calibration of the pen

1. After mounting the pen, click . Check if the origin is still set correctly. If not, adjust

and then click . Click the picture of the drag head module. If the remote is used to choose the module, press several times on the module until the correct one is chosen. The lights on the remote show which module is currently chosen to calibrate. The left light is module 1; the light next to that is module 2 and the second last light in the row is module 3. First change the type of tool, if necessary. The button of the current selected tool is grayed out and the parameters of this tool are shown. Set speed and pressure.

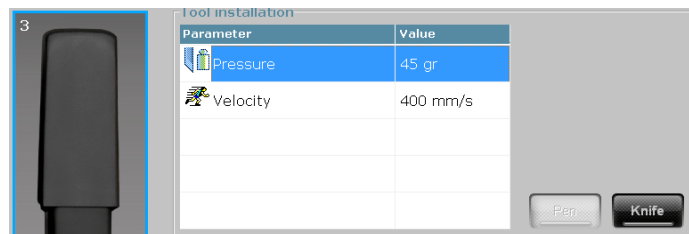









FIG 2-99
PARAMETERS PEN

2. Once a parameter is chosen to change, three new buttons will appear: ,  and . Press  to check if the speed and pressure are set correctly. Change, if necessary. Then press  to accept and store new values or  to leave the parameters unchanged.

2.7.2 Calibration of the knife

1. After mounting the drag knife, click . Check if the origin is still set correctly. If not, adjust and then click . Click the picture of the drag head module. If the remote is used to choose the module, press several times on the module until the correct one is chosen. The lights on the remote show which module is currently chosen to calibrate. The left light is module 1; the light next to that is module 2 and the second last light in the row is module 3. First change the type of tool, if necessary. The button of the currently selected tool is grayed out and the parameters of this tool are shown. Set speed and pressure.

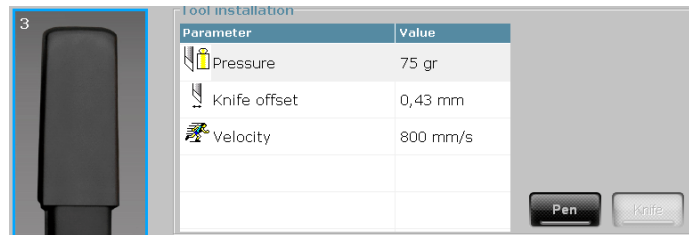





FIG 2-100
PARAMETERS DRAG KNIFE

2. Once a parameter is chosen to change, three new buttons appear: ,  and . Press  to check if the speed, knife offset and pressure are set correctly. Change, if necessary.

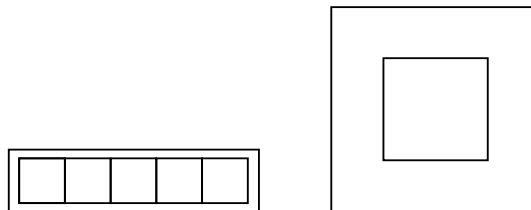

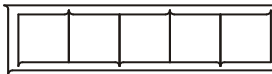



FIG 2-101
TEST PATTERN DRAG KNIFE

The knife pressure is set correctly when the test pattern cuts completely through the vinyl, the vinyl is removed and the blade tip visibly scratched the front side of the media backing. The blade should never cut through the backing but only slightly scratch the silicon coating and the first few fibers of the backing material.

Result of test pattern when the offset is set correctly: 

Result of test pattern when the offset is too low: 

Result of test pattern when the offset is too high: 

3. To change the value of a parameter, click it. Use the up and down arrow to change the parameter value. In case of setting the velocity, choose the value in the dropdown box.
4. Then press  to accept and store new values or  to leave the parameters unchanged.

2.8 Calibration of the camera unit

There are several calibrations related to the central unit. They are all done in the factory and do not need to be redone.

One calibration is the calibration of the distance between the camera unit and the origin of the used module. These calibration values are used to make sure that the different tools have the same origin in case more than one tool is necessary for a job.

Only when there is doubt in accuracy about the difference in origin between the different module positions, is it necessary to calibrate the camera unit.



ATTENTION: Only perform this calibration if instructed by a Summa technician.



ATTENTION: The calibration of the camera needs to be done for slot 3 if the router module (option) is mounted on the machine.

The calibration needs to be done with vinyl with a high contrast between vinyl colour and backing colour (black vinyl with white backing preferred). If the tangential module is calibrated, it is recommended to use the Kiss Cutting Tool.

This calibration can't be done with the remote.

1. Load black vinyl; install the module and tool.



2. Click  and click the picture of the camera unit in the window.
3. Click the slot that holds the module, which needs to be calibrated. The machine will cut out a large and a small square.



FIG 2-102
CALIBRATION DISTANCE MODULE ORIGIN - CAMERA

4. Carefully weed the large square, making sure the small middle square does not move. Click OK (or hit the enter key). The flatbed will now measure the position of the little square and calibrate automatically.

The height of the camera unit can be changed, so the built-in camera is always correctly focused. This is only necessary when the jobs are contour cutting jobs. It is recommended to raise the camera unit completely when normal cutting jobs are done. This will prevent the bottom of the camera unit hitting thick materials.

F SERIES™

3 AXIS CONTROL, REMOTE & PLUG-IN

3.1 Axis Control

Axis Control is standard delivered software that gives full control over the flatbed. The optimized design for touch screen control makes Axis Control the optimum interface for the machine operator.



ATTENTION: Always start up Axis Control before the machine is switched on or before the remote is connected. Close Axis Control always as last.

When the flatbed is powered on, a message will appear asking the operator permission to proceed with the start-up sequence. This prevent the table from accidentally moving after a power up (intended or unintended due for instance a power failure).

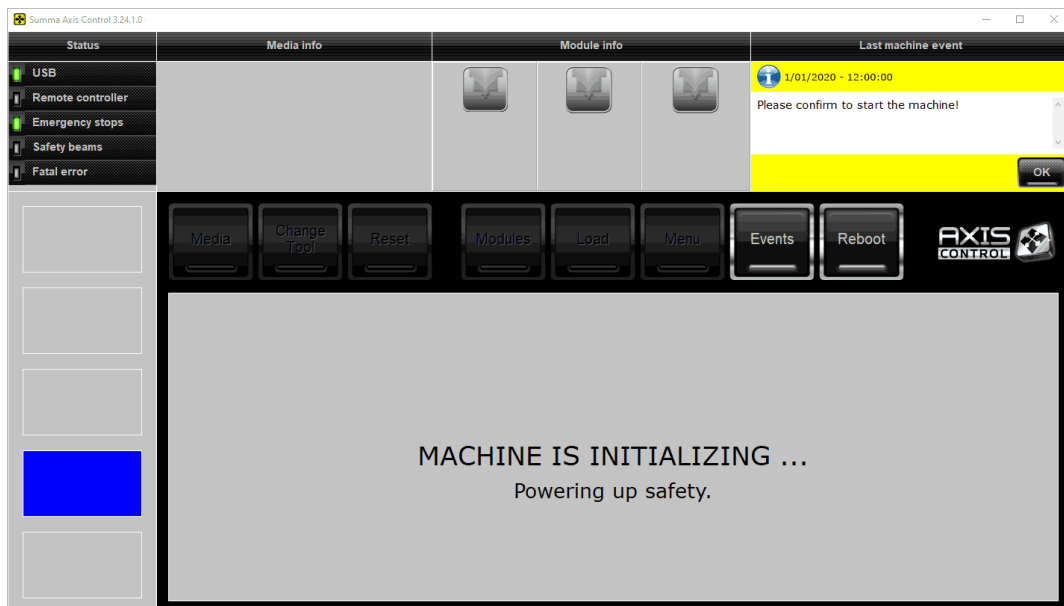



FIG 3-1
AXIS CONTROL CONFIRMATION FOR STARTUP

Click  to proceed with the startup sequence. In the next step the emergency buttons will be checked and after that the safety trip switches and the safety light beams . If any of those have a bad status then the startup procedure will halt and a message will appear on screen so the operator can correct.

3.1.1 Main Window

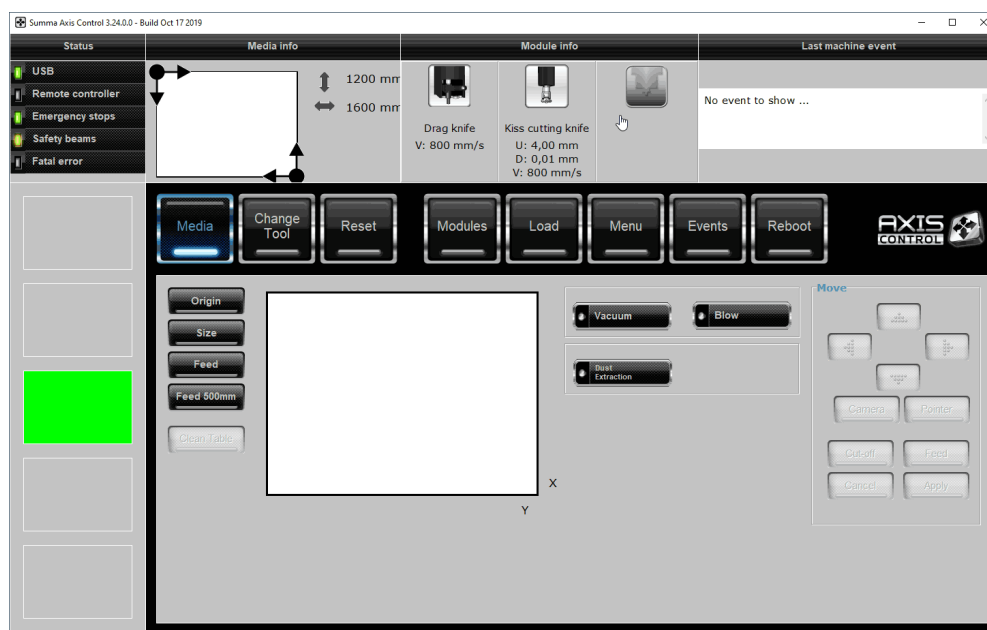

FIG 3-2
AXIS CONTROL MAIN WINDOW

After startup and initialization of the table, the window as above is displayed.

Status (left side of the screen)

:

This part displays the status of several items that are being monitored.

USB: can be green (connected) or red (not connected).

Remote controller: can be green (activated), or gray (not activated).

Emergency stop: can be green (machine ready), red (emergency stop pushed in) or grey (machine not connected).

Safety beam: can be green (machine active), orange (not active), red (interrupted) or grey (machine not connected).

Fatal error: can be red (fatal error happened) or grey (OK).

The large color blocks Make the status visible from a distance there are 5 possible colors.

Red: Means there is an error message that needs confirmation from the operator. Possible events: Emergence button pressed, trip switch or optical sensors from safety system were activated, fatal error or machine is rebooting.

Yellow: Means a warning message is displayed that needs confirmation from the operator.



Green: Normal status of machine, might be busy with a job or waiting for a job.



Blue: This means an intervention of the operator is needed. Is shown when a job is paused or interrupted because an operator intervention is needed.

White: Special status means the machine is not ready for sending a job to it, it might be busy re-flashing firmware or just offline.

Media info:

Displays the currently set media size.

Click left in the area to set the origin procedure. The origin jumps to the position clicked (at least to the nearest 100 (3.9")). Adjust with the arrow keys, if necessary. Click  to confirm or  to leave the origin unchanged.

Click right in the area to set the size procedure. The size jumps to the position clicked (at least to the nearest 100 (3.9")). Adjust with the arrow keys, if necessary. Click  to confirm or  to leave the size unchanged.

Module info:

Info about modules/tools. The mounted tool is shown and the up /down value and the speed set for internal tests. This info is very useful to quickly check if the up position is set high enough for the loaded media. Click the tool to go directly to the module menu with that tool.

Last machine event:

Here the last message, sent from the flatbed to the computer, is displayed. This message disappears if it has been acknowledged by the user.

Click on the Axis Control logo to show the model, serial number and firmware revision.

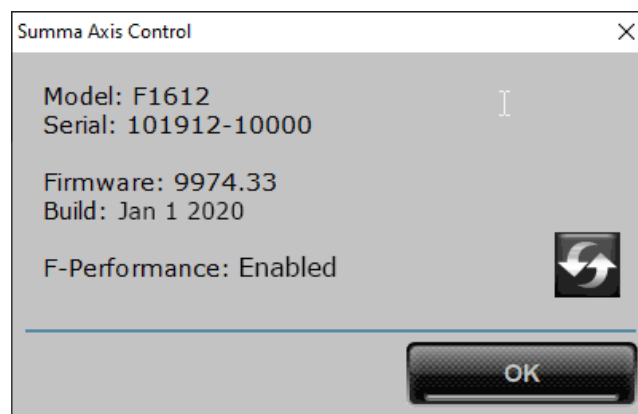

The rest of the Window shows the different menus of Axis Control to interact with the flatbed. They are explained in the next sections.

3.1.2 Media menu

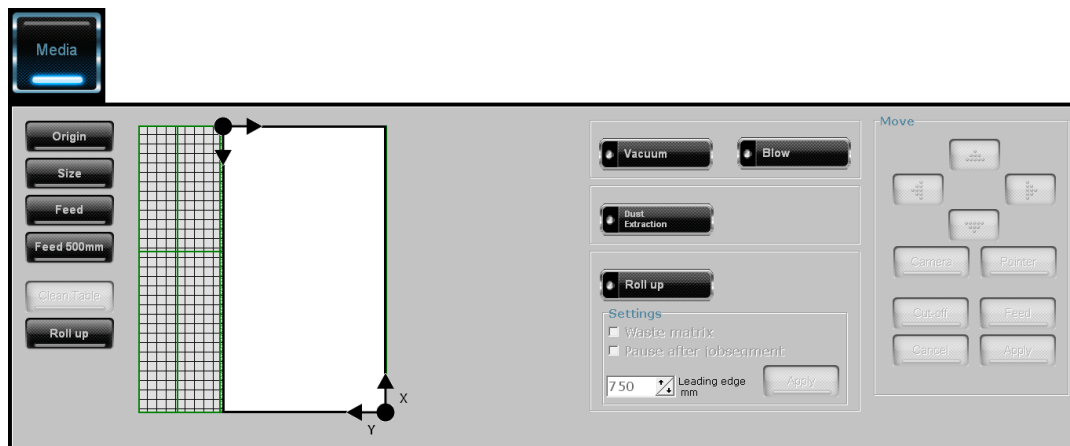

FIG 3-3
MEDIA MENU

Vacuum



Click the vacuum button to switch the vacuum on or off. The button is blue if the vacuum is switched on.



Click the Blow button to blow instead of creating a vacuum. The button is blue if the vacuum pumps are blowing.

The changes made in the status of the vacuum pump are only temporarily. Once a job or internal test is started, the vacuum pump is controlled again by the firmware and/or software.

Dust Extraction



Click the Dust extraction button to switch the vacuum cleaner on or off. The button is blue if the vacuum cleaner is on.

The dust extraction parameters function only when a router module (optional) is installed.

Roll-up (optional for F1612 models)



Click the Roll Up button to enable or disable the roll up. The roll up button is blue if the roll up is enabled.

Settings

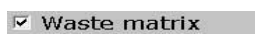

Check this box to use the waste matrix mode. In this mode, the media is not tensioned when it is rolled up. This is necessary when shapes are completely cut out.

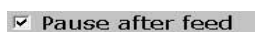

Check this box if the table has to pause after each feed. This gives the user the time to remove cut out shapes if needed.





This sets the size of the leading edge. If a new roll is loaded (use the load menu!), the table pauses after feeding this amount of media. This gives the user the opportunity to tape the material to an empty core.





NOTE: The parameters for the roll up are only available if the roll up (optional) is installed.

Move

The buttons under Move become highlighted if the origin or size button is clicked. They are described in section 1.4.

,  and  buttons are usable when media is loaded. These buttons have been explained in section 1.4. The feed button is not highlighted if the pneumatic pack (optional) is not installed.

If the router (optional) is installed, the table can be cleaned by clicking the  button. The router will then clean the loaded area. The speed at which the table is cleaned can be changed in the module menu (section 3.1.5).

If the roll up (optional) is installed, click the  button to roll up the media.



NOTE: On larger tables, the vacuum zones are indicated with green lines. The active vacuum zones are hatched.

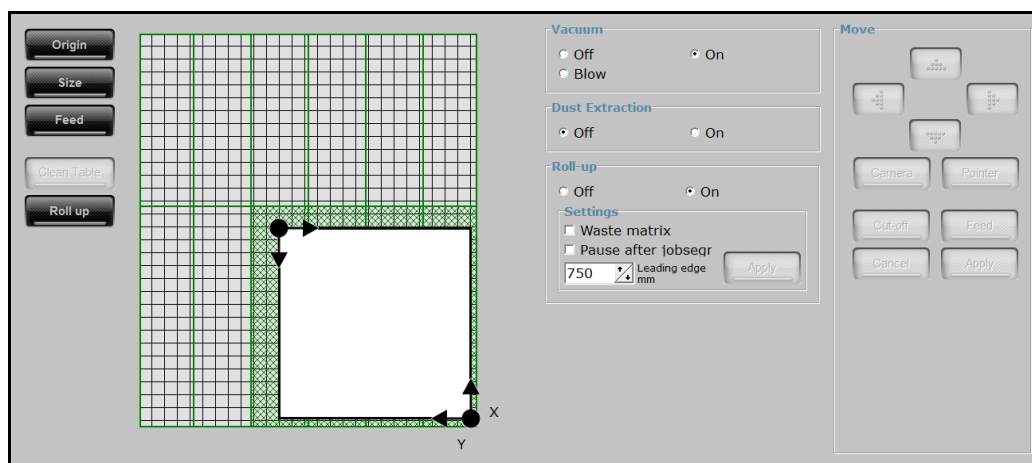

FIG 3-4
LOADED MEDIA LARGE TABLE

3.1.3 Change Tool

The change tool menu must be used when a module or tool is changed on the flatbed. If a tool or module is changed while the flatbed is not in the change tool menu, the machine will not detect the change and the cutting surface may be irreversibly damaged if a job is started afterwards.

After a module or tool change, click the Online button. The machine will then detect any module or tool change. It will also remind the operator to calibrate the tool before using it.

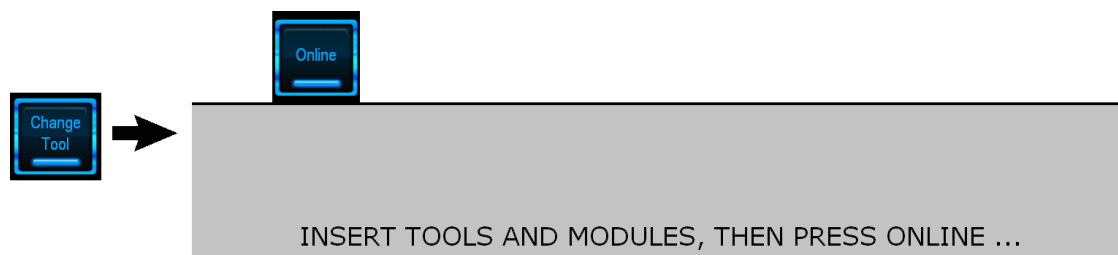

FIG 3-5
TOOL CHANGE MENU



WARNING: Only change/install a module or tool after clicking 'Change Tool' in Axis Control. The machine will not make any unexpected movements after the change tool button is pressed and as long as the online button is visible. The power to the motors is cut, so after Online is clicked, the motors return to their original position. Do not move them too far out of their original position.

3.1.4 Reset

Click Reset to stop the table with the current job. The origin of the loaded media is also reset.



FIG 3-6
RESET BUTTON



NOTE: When the table is cutting a job from Summa GoProduce, there are more options available than just resetting (see section 3.1.11).

3.1.5 Modules

This menu is the menu to set the tool parameters. Each time a tool is changed, the parameters need to be at least checked.

If the machine detects a new tool is installed (after change tool), it will refuse to use that tool until it has been calibrated.

The module that is chosen to calibrate has a blue border around it. The parameter that is currently chosen to calibrate is highlighted in blue or magnified.

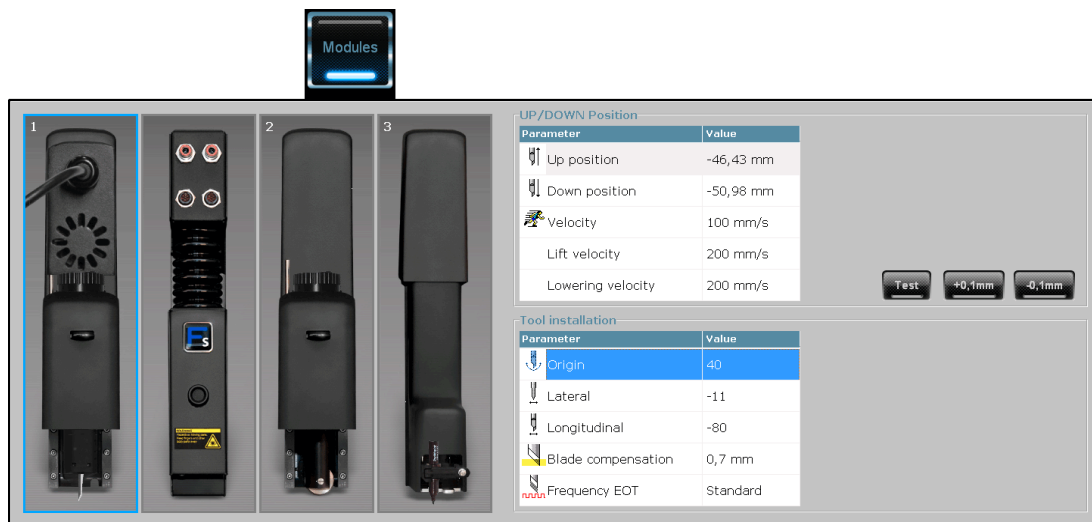

FIG 3-7
TOOL CALIBRATION MENU (MODULE MENU)



ATTENTION: The up and down head positions can also be set with the remote.

3.1.6 Load

With this menu media is loaded. How to load media is explained in section 1.4.

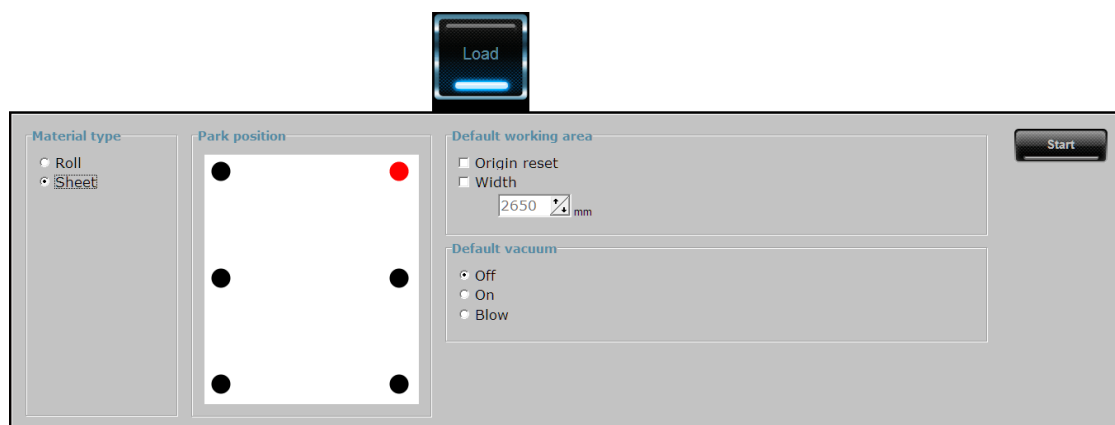

FIG 3-8
LOAD MENU

3.1.7 Menu

With this menu the standard parameters for the cutting table can be changed. Select the parameter that needs to be changed. The background of the selected parameter will become blue. Then use the up/down arrow to change the value. The software for sending jobs may overwrite some of the parameters. Press Apply to save the value or Cancel to deselect the parameter without changing the value.

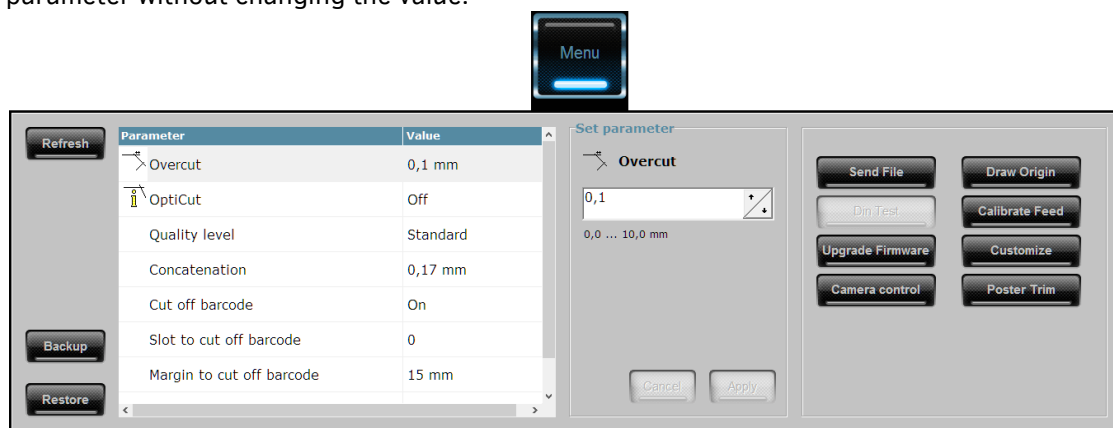

FIG 3-9
PARAMETER MENU

Overcut: with this parameter weeding is facilitated. Each time the knife goes up or down, the cutter cuts a bit further than it should.

OptiCut: increases the cutting quality in case the knife is worn out or not calibrated correctly. OptiCut is default-set to Off.

Quality level: is default set to High, setting it to Standard increases the throughput.

Concatenation: is used to have a smoother velocity profile when cutting curves. The default value is 0,17 mm.

Cut off barcode: If this parameter is set to "On", the table will cut off the media in front of the barcode. The table will first read the barcode to retrieve the cut data and before it will read the marks. The media will be cut before the barcode.

Slot to cut off barcode: This parameter determines which tool should be used to cut off the media. The parameter refers to a slot position, not to a tool.

Margin to cut off barcode: With this the distance between the cut-off line and the barcode can be set. If the margin is larger than the offset of the barcode from the origin, the media will be cut off at the origin.

Velocity to clean the table: This is the speed at which the table will be cleaned with the router module as soon as the cleaning option is activated from the media menu (see section 3.1.2).

Operator zone: Can be set to Full or rear. When set at rear, then the first half of the table is not used for cutting. Like this the operator can remove what has already been cut out while the job will be continued at the rear of the table.

Other possible actions in this menu are:

Backup and **Restore**. This is used to save or restore a backup of the current parameter settings of the flatbed.



NOTE: It is advised to make a backup file just after installation of the machine.

Send File is used to send a test file to the flatbed. This action can be used for remote troubleshooting.

Din Test starts an internal cut test (only if the drag knife or kiss cutting knife is the selected tool – to select a different tool, go to module menu).

Upgrade Firmware is used to upgrade the internal firmware of the flatbed. A choice is offered to either install from a local drive or to download the latest version from www.summa.eu.

Draw Origin is used to draw the boundaries. First put a pen in the drag module. Consequently, set the tool to pen in the menu. Click Draw Origin. When the conveyer belt is mounted, the table will draw a line at the right side, marking the origin. At the left side a line will be drawn, marking the maximum Y size. When no conveyer belt is mounted, the table will draw a rectangle, marking the origin and maximum media size.

Calibrate Feed is a calibration procedure to compensate for errors in the X axis when cutting in panels (without registration mark recognition). You have the choice between an automatic and a manual calibration. The manual calibration needs to be used if the camera can't detect the cut out registration marks.

Customize is used to set the parameters in Axis Control and for the remote.

Camera control is used to set the parameters for the camera, so it can read the barcode and marks. The camera is normally calibrated to detect black marks on white vinyl. Most other combinations of colours can also be detected with the standard settings. It is possible to adjust this standard setting to read less obvious colour combinations of media and marks.

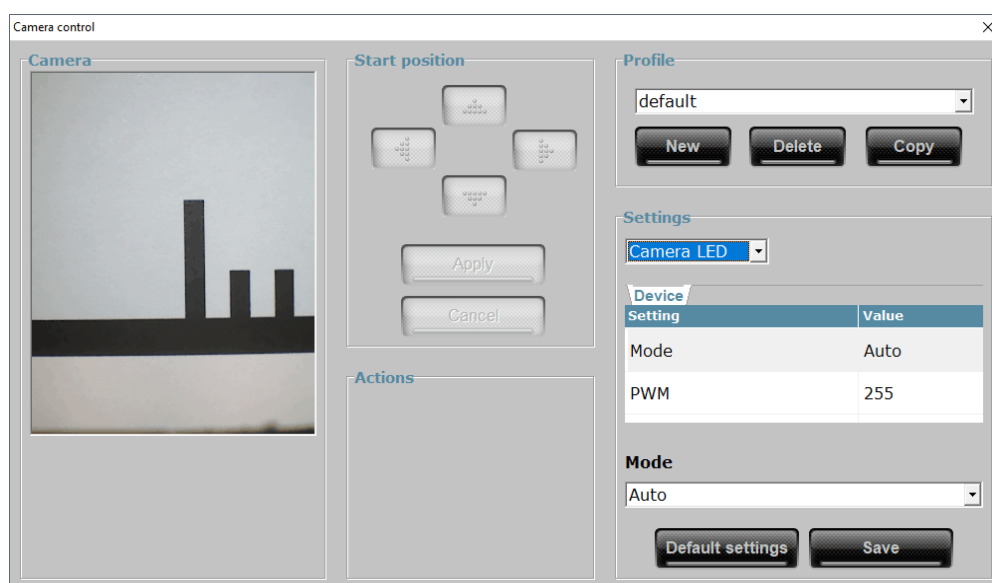

The left side of the window (Camera) shows the camera view. The middle (Start position and Actions) will show active buttons that can be used while setting the parameters. The right side can save the profile and select the settings, whose parameters need to be set.

Some profiles are predefined and are installed when Axis Control is installed (default and reflective). To use them click the dropdown box just under profile and choose the correct profile.

A predefined profile can be altered or a new profile can be made. It is advised not to change a default profile, but copy it and change the parameters of the copy.

The parameters of the following settings can be set.

Camera LED

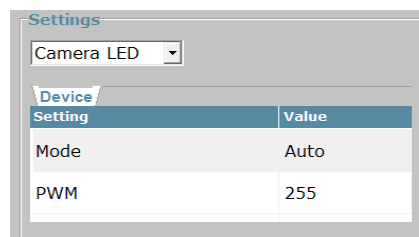

Click Mode to set the LED to Always ON, Always OFF.

Click PWM and set the LED light intensity with the slider between OFF (value 0) and maximum (255).

Calibration

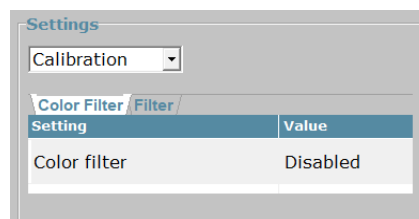

This is used to set the filter (profile) that will be used when Axis Control searches for marks. There are two filters. In order to switch between the setting of each filter click the tab.

First set a colour filter that can be disabled or enabled. Click the filter test button to expand the window with an extra view of the camera. The different tabs in that view show the result when changes in the filter are applied.

The colour filter has four parameters: Minimum hue and maximum hue to filter out specific colours and a minimum and maximum saturation to filter out the grey component of the colour.

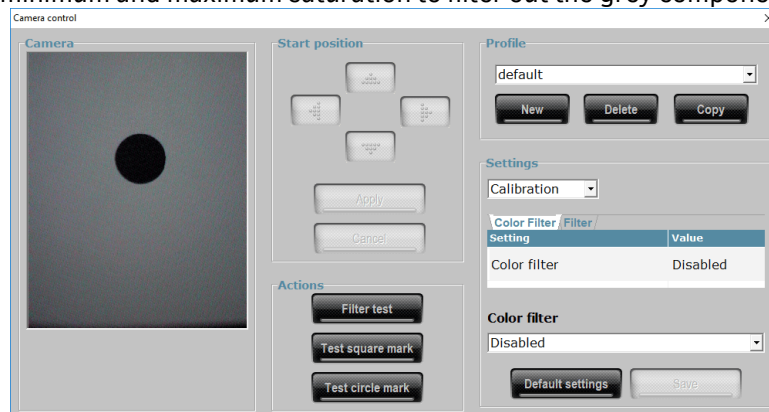

The second filter (just called filter) is more important. Click the tab to show the parameter settings of that filter.

There are 5 parameters. Click the parameter to change it. A slider under the set parameter is then shown to adjust the parameter. Click the filter test button to expand the window for an extra camera view. This extra view has 5 tabs. Each tab corresponds more or less with a parameter of the filter. Click the first tab to see what the first parameter does to the camera view. Click the second tab to check what the second parameter does and so on. The aim is to get a clear thin line in the last tab.

Median filter: preserves the edges, but smooths out patterns.

Truncate filter: sets all grey levels below a certain value in relation to that value.

Blur: Blurs the picture slightly in order to smooth out sharper edges.

Edge smoothing: blurs out the pattern nears the edges.

Threshold: sets the level to decide whether an edge is white or black.

Example: parameter settings to hide the pattern of reflective vinyl:

Click the filter test button.

1. Change the median filter; be sure the first tab is shown.
2. Change the truncate filter; be sure the second tab is shown.
3. Change the blur filter; be sure the third tab is shown.
4. Change edge smoothing; be sure the fourth tab is shown.
5. Change Threshold; be sure the fifth tab is shown.

Click the Test circle mark button. If the circle is recognized as a mark, a green circle will be drawn around it.

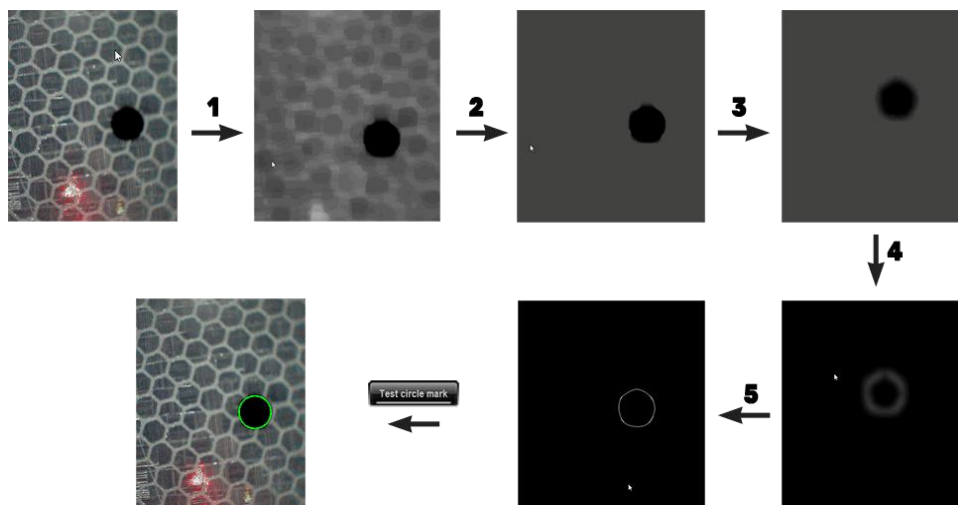

Barcode

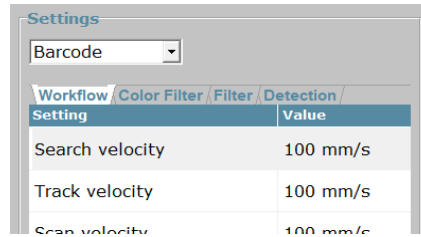

This filter is used when the camera reads the barcode. There are 4 sets of parameters.

The workflow parameters determine how fast the barcode is read. There are three speed parameters.

1. Search velocity: Is the speed at which the camera searches for the next (or first) barcode.
2. Track velocity: is the speed at which the camera searches for the right side of the barcode.
3. Scan velocity: is the speed at which the barcode is read.

Select a speed and change it with the slider at the bottom, if necessary.

The final parameter is scan retries. This determines how many times the camera tries to read the barcode if it fails. The reading speed is automatically lowered when the barcode is re-read.

The colour filter and the filter settings function similar as with the calibration settings.

There is one detection parameter. It is called 'Contrast' and can be set if a light barcode needs to be read on darker material.

Click  to check if the barcode can be read. The cutter will prompt the user to set the knife under the barcode. After that, the barcode will be scanned. If the barcode is detected correctly, a window will appear with the value, that has been read.

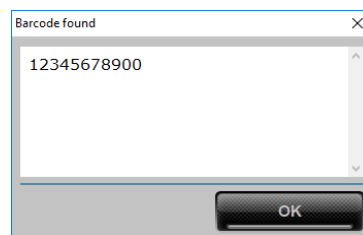

Poster Trim

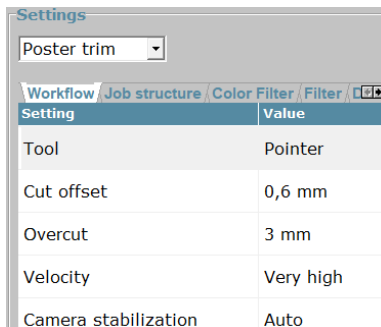

Setting	Value
Tool	Pointer
Cut offset	0,6 mm
Overcut	3 mm
Velocity	Very high
Camera stabilization	Auto

The poster trim function is an option, enabling to trim posters without the need for special marks and without the use of Summa GoProduce. When the posters are printed out, a black border of 5 mm around them needs to be printed with a distance of 5 mm between the copies. To start the job, please refer to section 3.4.

Click the first tab in order to set the workflow parameters.

Tool: With this parameter the tool, that will be used for trimming, can be set.

Cut Offset: Is the distance between the line that will be cut and the inside of the black border.

OverCut: Is the distance, which the knife will cut further in each corner.

Velocity: is the speed at which the borders will be read. Lower this value if the computer resources are limited.

Camera stabilization: The camera adjusts the brightness automatically, according to the received amount of light. This might take some time. With this parameter the time the camera waits can be set. When set at 'automatic', the camera will wait 90/5 until the brightness is stable. When set at 'fixed', the time the camera waits can be set at a specific time. The option 'none' means the camera does not wait. The recommended setting is 'automatic'.

Click the second tab to see the workflow parameters. The amount of parameters that can be set in this tab depends on the chosen job type (the way the posters are nested). The extra parameters help to speed up the reading of the borders.

Nesting: there are 4 settings possible.

Single poster: Only one poster will be cut out. No extra parameters are needed.

Single row: Only one row of posters will be read and cut. Then the next row will be read and cut. The posters may differ in size in both directions. However, they must be aligned left or right and top or bottom. Set the parameters correctly (as they are printed out).

Multiple copies: All posters must have the same size. All rows will be cut out, the rows do not have to be complete. The copies must be aligned left or right. Set the parameter to left or right aligned.

Random: Although the setting has 'random' as name, there are some limitations to the position of the individual posters. Every frame, which is not located in the start position, must be connected to at least one other frame (connected means: at a distance of 5 mm with white space between it). More info see section 3.4.

Once this parameter is set, set the horizontal alignment parameter correctly (left or right).

The next two tabs are filters. The colour filter and the filter settings function similarly as with the calibration settings.

There is one detection parameter. It is called 'contrast' and can be set if a light barcode needs to be read on darker material.

Click  to check if the frames can be read. The table will prompt the user to set the knife under the frame. Do this at the left side of the table when the jobs are left aligned, on the right side if the jobs are right aligned. Click OK. The camera will check if the frames can be read.

3.1.8 Events

This menu shows all the messages that have been displayed by the flatbed cutter.

There are three types of messages:

Info: Is a message of the machine to the user.

Warning: Is a message from the machine to the user, reminding the user a certain action needs to be taken.

Error: Is a message from the machine, reporting an error that needs the user's attention.

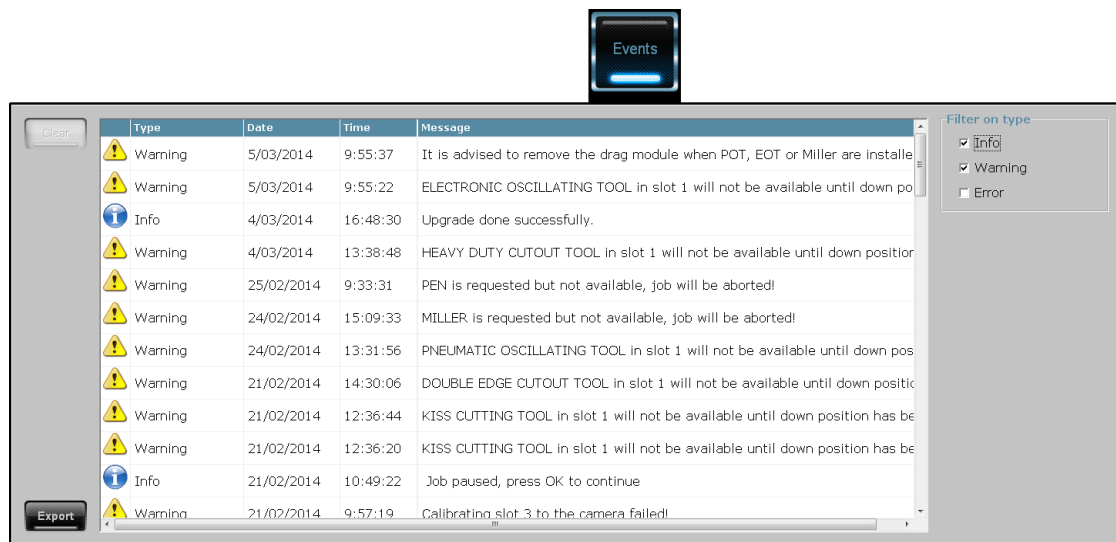

FIG 3-10
EVENT MENU

3.1.9 Reboot

This button is for restarting the machine completely. It is a 'warm restart'. The flatbed goes through its entire initialization procedure, that is normally run when the machine is switched off and back on again.

This reboot does not reboot the camera in the flatbed.

3.1.10 Color Axis Control icon

The colour of the icon of Axis Control in the tray menu can differ.

The normal colour is **white**.

When the icon is **yellow**, this means the flatbed is busy (resetting, cutting a test pattern, waiting for a response from the user,...).

When the icon colour is **red**, this means Axis Control has no connection with the flatbed cutter.

3.1.11 Axis Control options when table is busy cutting jobs from Summa GoProduce

When a job is started from Summa GoProduce, the safety poles become active () and the view of Axis Control changes. There are now two main buttons.



Click this button to stop the current job. The table will finish the vectors, loaded in the buffer and reset the origin. The computer will send the rest of the job but the table will not cut it out.



Click this button to pause the current job. The table will finish the vectors loaded in the buffer, pause and show the two new buttons.



Click this button to resume the job. The table will start cutting the rest of the job.



When the table is paused, the job can be aborted by clicking this button. The carriage will move back to the current origin. The computer will send the rest of the job but the table will not cut it out.

If the safety beams are interrupted or the trip switches in the bumpers are triggered, then the table will stop and the table will pause. Summa Axis Control will give a message. Click the OK button in the message window to continue.



NOTE: Do not use the safety measures as a pause button. It will reduce the cutting quality. A controlled pause makes sure all vectors are cut out with the correct speed and acceleration

3.2 Remote control (optional)

The remote control makes it possible for the user to come closer to the machine when this is necessary for certain actions. It is used when:

- Setting the origin and size of loaded media.
- Setting the up and down positions of the knives in the tools.
- Switching the vacuum pump on/off.



WARNING: While the remote is used, the operator can approach the table. He can even pass the safety beams without setting them off. So, the user must be extra careful and stay away of the parts he is controlling with the remote.

There are two methods of connecting the remote with the computer. Either through connection via a Bluetooth dongle or through a wireless bar. The wireless bar is the current (latest) way of connecting.

3.2.1 Wireless Bar setup

First time connection:

It's not necessary to install special drivers before connecting the wireless bar. Just connect the bar to the computer with the USB connector and wait until Windows has installed the correct driver. This c e sync button on the bar (the sync LED will blink).

Then press the sync button on the remote (a red button at the back; see the white arrow figure below). First all 4 LED's on the remote will blink. Wait until only one is activated. The sync LED on the bar will now also be activated.

Start Axis Control. The status indicator in front of the remote controller will be green.

Reconnecting:

After this first time installation, reconnecting the remote is easier.

It is possible that the remote auto connects. If it does not auto connect, then just press the "1" and "2" button on the remote after Axis Control is started. The connection will be established.

If the battery has been changed, it is possible that the sync button on the bar needs to be pressed prior to pressing the "1" and "2" button to connect.



3.2.2 Name of the buttons on the remote



Arrow buttons.



Enter button.



Module (select) button.



Origin/Test button.



Up button



Down button



Shift button (back of remote)

3.2.3 Setting the origin and size with the remote

Press on the origin/test button to set the origin or just press one of the arrow keys. The head will move this way the pointer is set over the origin. The origin can now be changed by pressing the arrow keys. Push the enter button to set the origin. While the origin is set, the (left) origin LED is flashing.

If enter is pressed, this LED will still flash for a while. Do not press any buttons on the remote while the LED is still flashing.

Press the shift and origin/test button simultaneously to set the media size (press the shift key first). The head will move this way the pointer is set over the upper left corner of the media. The size can now be changed by pressing the arrow keys. Push the enter button to set the size. While the size is set, the (right) size LED is flashing.

If enter is pressed, this LED will still flash for a while. This can take quite a long time if the media width was changed a lot. The machine has to reposition the vacuum selector. Do not press any buttons on the remote while the LED is still flashing.

3.2.4 Setting the tool/knife up and down position with the remote

Setting the up and down position of the tool/knife is best done with the remote. In order to set the up and down position, follow the below procedure.

1. Move the origin above the loaded media.
2. Press the module button. If more than one module with a tool is mounted on the machine, the module to calibrate can be selected by pressing the module button several times. The module that is selected to calibrate is indicated with the LEDs at the bottom of the remote (M1, M2 or M3).
3. First set the up position. Do this by pressing the up button and lowering the tool/knife with the arrow buttons. Once the correct height is set, press the enter button.



ATTENTION: The up position is linked to the down position of the tool/knife for safety reasons. If the down position has not been set yet (still at zero) it will be impossible to set the up position. In that case, set the down position first and afterwards the up position.

4. Then set the down position. Do this by pressing the down button. Lower the tool/knife with the arrow buttons. Press the origin/test button to check the depth. If the depth is not correct, then correct it by pressing the arrow keys again. Once the correct depth is set, press the enter button.



NOTE: Make sure the speed of the tool/knife is the same speed at which the job will be done.



ATTENTION: When using the kiss cutting tool, only the down position needs to be set. The up position is then automatically set 4 mm higher.

3.2.5 Switching vacuum pump on/off

The vacuum pump can be switched on and off by pressing the enter button. Pressing it together with the shift button sets the pump to blow.

3.3 Plug-ins

Plug-ins for Corel and Illustrator exist to make the workflow easier.

3.3.1 Plug-in for Illustrator (PC)

The extra menu (Summa GoProduce) under the file contains one sub menu.



Add Summa Registration Marks

If the sub menu is used, following things happen:

- The layer 'Regmark' is made the top layer. All objects in it are deleted and it is locked.
- All objects in all unlocked and visible layers under the Regmark layer are selected.
- The Regmark layer is unlocked.
- Registration marks (circles with Ø5mm) are put around the selected objects and an arrow is added to easily recognize the orientation. All these registration marks and the orientation mark are saved in the Regmark layer.
- The Regmark layer is locked.

In order to prepare a file for Summa GoProduce do following:

- Make the layer(s) with the print data on it temporarily a template layer.
- Save file as pdf file (minimum pdf version 1.5). Make sure the option to save layers is on.
- Set property of print data layer again normal.



NOTE: The same can be done when saving det print data, just change the properties of the layers with cut data temporarily to template.

To set the template for the F Series on the correct place do following:

- Open Illustrator.
- Go to File > New from template (a dialogue box will open. Choose a template from the Illustrator template directory).
- Open Windows explorer and go to directory C:\Program Files (x86)\Summa Flatbed Tools or C:\Program Files (x86)\Summa GoSuite Tools\
- Go to the template subdirectory, select the Illustrator template (file with extension ait), right click and select copy.
- Go to the dialogue box in Illustrator and copy the template there.
- Click the new button.



NOTE: The next time a new file from the template is needed, just go to File > New from Template, and select the template for the F Series.

3.3.2 Plug-in for Corel (PC)

The Toolbar in Corel contains three icons.



The first icon is used to start a new drawing from the F Series template. If the icon is clicked, then following things happen:

- A new drawing is started from the F Series template.
- All necessary layers are created and the working area is 1200mm x 1600mm (portrait).
- The active layer is the layer for print data.

If the second icon is clicked, following things happen:

- The layer 'Regmark' is made the top layer, all objects in it are deleted and it is locked.
- All objects in all unlocked and visible layers under the Regmark layer are selected.
- The Regmark layer is unlocked.
- Registration marks (circles with Ø5mm) are put around the selected objects and an arrow is added to easily recognize the orientation. All these registration marks and the orientation mark are saved in the Regmark layer.
- The Regmark layer is locked.

The third icon is used to create a pdf file that is ready for Summa GoProduce to import. If the icon is clicked, following things happen:

- All objects in the unlocked layers and in the layers where the printing/exporting is not disabled are selected (so the objects in the Regmark layer and Cut Out Squares layer also).
- A dialogue box is opened, a directory (same one as the one that was used the last time with this function) and the file name (current file name) is suggested.
- Change the directory and file name, if necessary, then click 'save' without changing any options.

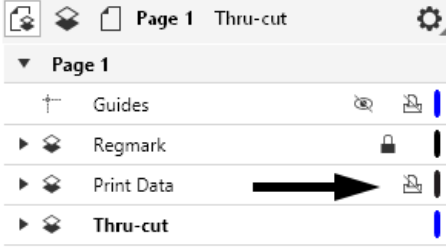
 <p>NOTE:</p>		<p>Click the printer icon of the print layer before saving it to a pdf file. Otherwise the pdf file will have too much unnecessary data in it and importing it in Summa GoProduce will take too long.</p>

3.3.3 Plug-in for Illustrator for Mac (from CS4 up)

With this plug-in Summa GoProduce marks can be set. The Summa menu is added in the File menu of Illustrator. The Plug-in is called SummaCS4mac.aip, version 1.0.0.0 for Illustrator CS4 and CS5. For Illustrator CS6 it is called SummaCS6mac.aip and for Illustrator CC it is called SummaCCmac.aip.

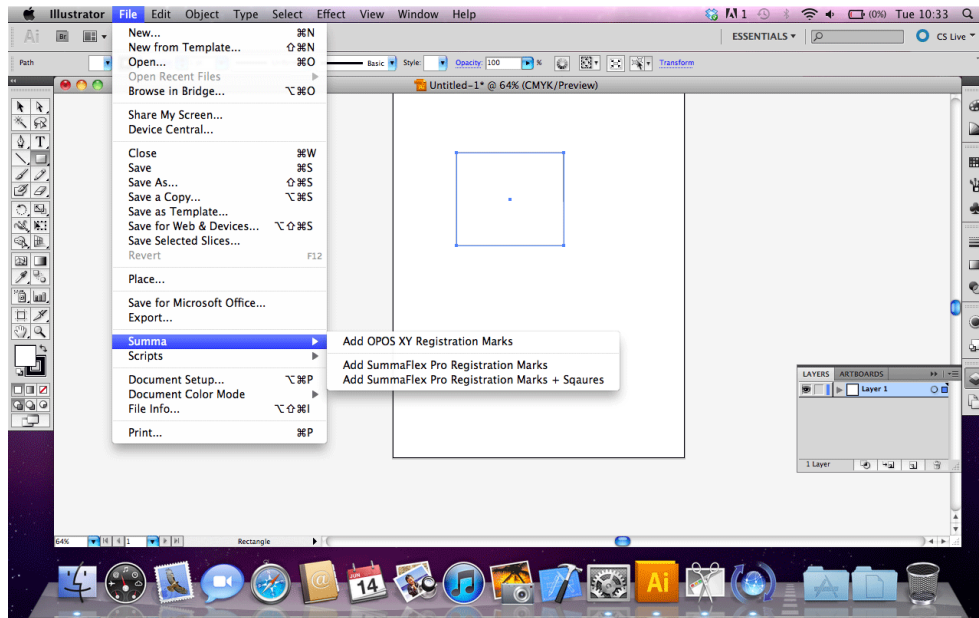
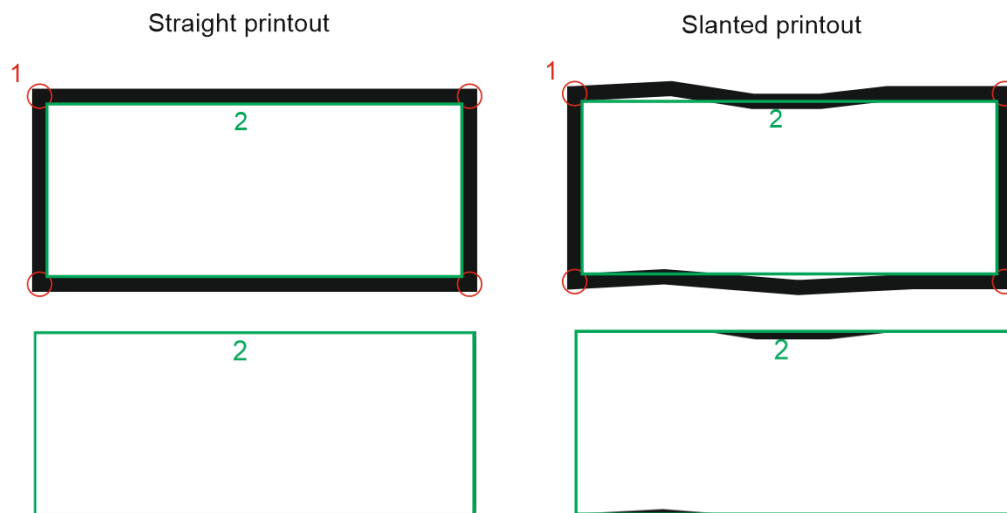

FIG 3-11
PLUG-IN FOR ILLUSTRATOR ON MAC

3.4 Poster Trim

The Poster Trim workflow enables users to cut posters directly on the flatbed cutter without using Summa GoProduce. The RIP software must print a black border of 5 mm around each poster, with a 5 mm spacing between adjacent posters. Each poster must share at least one border side with another poster.

For reliable results, make sure posters are printed straight. Slanted prints may result in visible black or white edges after cutting. On flexible materials such as textiles, minor deviations may appear for jobs longer than 3 meters due to material stretching.



To minimize scanning time, posters can be grouped in different configurations. Ensure the configuration is set correctly before starting the job.

3.4.1 Possible Configurations

- Single poster:



- Single row (one or multiple rows, with a maximum distance of 250 mm):

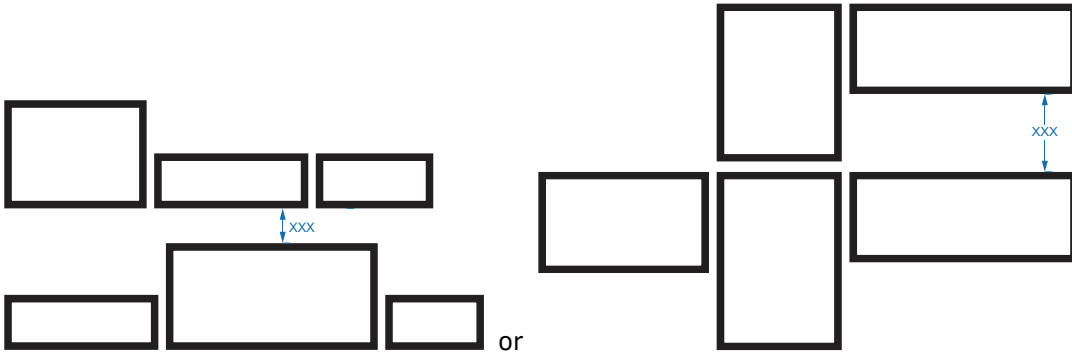

- Multi-copy layout:

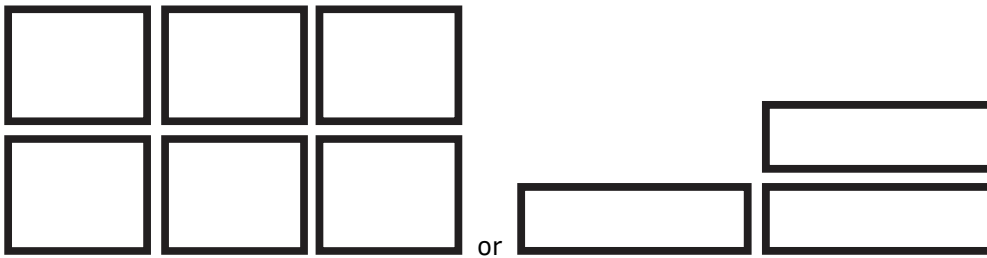

- Random layout:

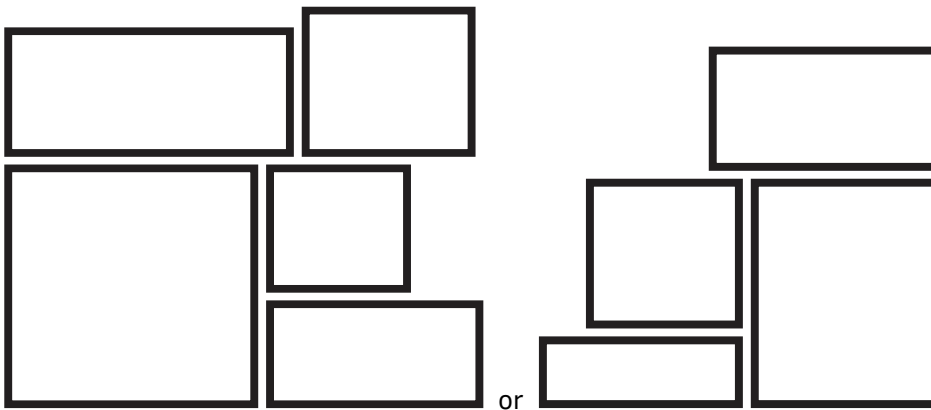

3.4.2 Setting Up the Poster Trim Job

1. Click **Menu > Poster Trim**. The following window will open.

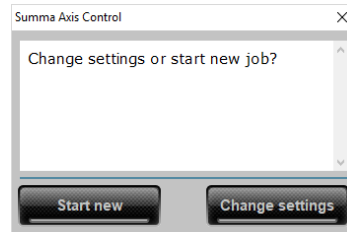

2. Click **Change Settings** to verify that all parameters are configured correctly. All the parameters for poster trimming are explained in section 3.1.7. In most cases, only the parameters in the **Workflow** and **Job structure** tabs need checking.

Setting	Value
Tool	Double Edge cut...
Cut offset	0 mm
Overcut	2 mm
Velocity	High
Camera stabilization	Auto

Make sure the *Tool*, *Cut offset* and *Velocity* are set correctly. The cut offset is measured from the inside of the black border toward the center of the poster. A larger offset will result in a smaller final poster size. *Overcut* and *Camera stabilization* are usually not altered.

Setting	Value
Horizontal alignment	Right
Nesting	Random

Nesting

- Random
- Single poster
- Single row
- Multicopy
- Random

Select the correct nesting type according to your layout, then adjust other parameters as needed.

3. If you wish to reuse these settings later, save the configuration under a recognizable name. To do so, click **Copy**, enter a name, and click **Save**. You can easily reload it via the dropdown list.

3.4.3 Starting the job

1. Load the media on the cutting table and verify the printed layout. Choose the configuration that matches the print.
2. Click **Menu > Poster Trim**. The following window will open.

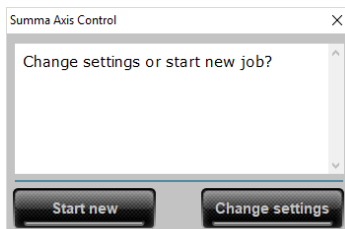

3. Click **Start New**. The following window will open, showing a live camera view and control arrows.

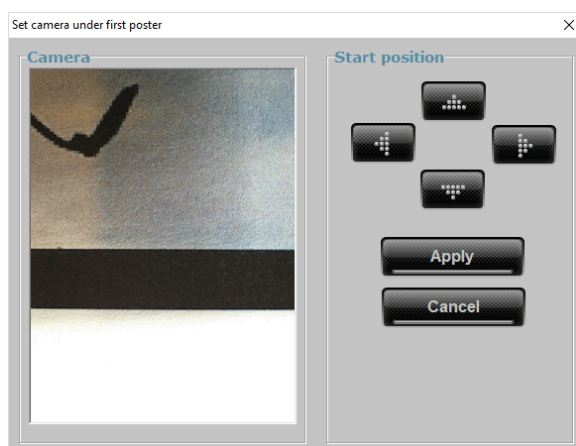

4. Use the arrows to position the camera correctly. If alignment is set to *right*, move the camera to the outermost right poster; if *left*, move it to the outermost left. For reliable detection, place the camera at least 10 cm away from the poster corner so the corner itself is not visible in the camera view. Ensure that the 5 mm black border around the poster is roughly centered in the camera image. This prevents the system from capturing print data during detection.
5. Click **Apply** to start the job. The system will automatically search for the poster's corner points and cut straight lines between them. It does not follow the printed border line.

4 MAINTENANCE AND CLEANING

4.1 General Information

The cutting tables have a number of sliding surfaces, made of smooth metals and plastics. They are virtually friction-free and require no lubrication by the operator. They will, however, collect dust and lint that may affect the cutter's performance. Keep the flatbed as clean as possible by using a dust cover when not in use. When necessary, clean the unit with a soft cloth, dampened with isopropyl alcohol or mild detergent. Do not use abrasives.

It is also recommended to check the knife on a regular basis. Replace the knife if the knife tip is worn down or broken off.

There is an internal counter that takes track of the hours the machine has operated. After a certain time the machine will give a message, saying that service maintenance needs to be done. This service maintenance needs to be done by a service technician, trained by Summa. It is highly recommended to have this maintenance otherwise the cutting quality and the lifetime may be reduced. Those maintenance actions are not described in this manual. They are described in the service manual. The maintenance described here can/should be done by the operator. There are two levels of maintenance for the operator: the daily maintenance and the weekly/monthly maintenance.



WARNING: For safety reasons, always switch off the machine before starting the visual inspection. Most maintenance procedures are also best carried out with the machine switched off. Only in rare cases it is necessary for the machine to be powered on during maintenance procedures. If this is the case, follow the described procedure.

4.1.1 Daily maintenance

The daily maintenance actions are:

1. Each day before starting up the machine, move the conveyor manually so it is moved forward for about 1 meter.
2. Free the machine of any dust and residue that was left from the cut materials.
3. Check the correct function of the safety features (laser beam and emergency stops).

4.1.2 Weekly/monthly maintenance

The frequency of the following described maintenance procedures depends on how much the cutter is used. Most of those maintenance actions are triggered by a visual inspection of the machine and its components or by deterioration in the cut quality. It is recommended to do a complete visual inspection of the machine and all its components at least once a week.

4.1.2.1 Cleaning the nose piece (Kiss Cutting Knife only)

The nose piece may accumulate residue from the vinyl that will result in poor cut quality. The typical indication of a dirty nose piece is an interruption of the cutting line every 12 mm (0.5").

Cleaning the nose piece:

1. Remove the Kiss Cutting Tool by turning it counterclockwise. Use the menu Change tool in Axis Control or switch off the cutter before doing this.
2. Observe the orientation of the nose piece in the tool and then push it out of its holder.
3. Remove any remaining vinyl residue, using a brush or a pair of tweezers.
4. Put the nose piece back.
5. Install the Kiss Cutting Knife again in the module.



FIG 4-1
NOSE PIECE KISS CUTTING TOOL

4.1.2.2 Cleaning the gliding disk (Cutout and EOT)

The gliding disk may accumulate residue from the vinyl that will result in poor cut quality.

Cleaning the gliding disk:

1. Remove the Single Edge, Double Edge Tool or EOT by turning it counterclockwise. Use the menu change tool in Axis Control or switch off the cutter.
2. Remove any remaining vinyl residue, using a brush or a pair of tweezers or with compressed air. Remove the gliding disk from the tool, if necessary.
3. Install the tool again in the module.

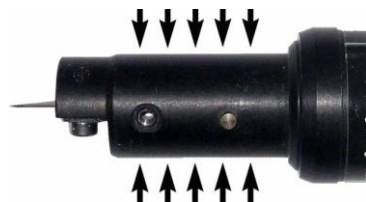

FIG 4-2
GLIDING SURFACE



NOTE: The gliding surfaces may be lubricated with a dry Teflon spray before the gliding disk is set back on the tool.

4.1.2.3 Replacing the knife guide of the EOT

The very high frequency of the EOT means that wear of moving parts inside the EOT is unavoidable. The level of wear is unpredictable since it depends on various parameters, such as thickness of the cut material, its consistency, usage and other general operational parameters. The only part the operator can replace is the knife guide. If other parts are worn, the EOT will need to be serviced in a Summa service center.

Replacing the knife guide:

1. Remove the EOT from the module. Use the menu Change Tool in Axis Control or switch off the cutter.
2. Remove the gliding disk (if it was mounted) and remove the knife.
3. Loosen the knife guide by removing the two setscrews.
4. Turn those setscrews in the two threaded holes right next to the holes the screws came out of for a turn or three.
5. Gently remove the knife guide by pulling on those setscrews.
6. Put the new knife guide in and proceed in the reverse order of removal.



FIG 4-3

KNIFE GUIDE WITH SCREWS FOR REMOVING AND REPLACING

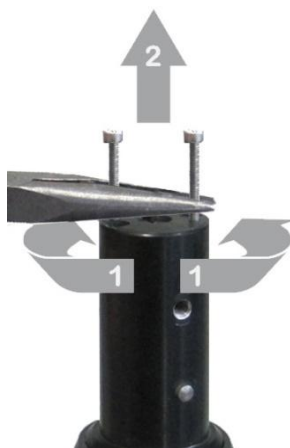

FIG 4-4

USAGE OF AN EXTRA TOOL IF THE KNIFE GUIDE GRIPS IN THE SHAFT

4.1.2.4 Cleaning the conveyor belt or protective mat

After a while a lot of dust will gather in the conveyor belt. This will reduce the vacuum. The media will not stay on its place and the cutting quality will deteriorate.

Cleaning the conveyor (protective mat):

Set the vacuum pump on 'blow' and clean the conveyor with a vacuum cleaner.

When a miller is mounted on the machine, this can be used to vacuum the conveyor belt or to route the underlay. Click the media button in Axis Control. Two extra options are visible:

Clean table: Push this button to vacuum the table (loaded area). The miller in the router will run, but it will not touch the surface.

Dust extraction: Click the radio button to set it on or off.



NOTE: If a lighter router underlay is used, the brush should barely touch the underlay. If the conveyor type of mat is cleaned, the brush can be used to 'brush' the conveyor belt.

4.1.2.5 Cleaning the protection brushes at the sides

The brushes at the sides can accumulate dust. Use a vacuum cleaner to clean them. Do not use compressed air, since this will blow all the dust inside the machine.

4.1.2.6 Cleaning Guide rails

The guide rails normally don't need lubrication. The carriages have a built-in reservoir with lubrication. However, should the rails be very dirty, they can be cleaned as follows.

Cleaning the rails:

1. Clean the lengths of the rails with a lint-free rag (start from the carriages and move away from it).
2. Soak another lint-free rag with lubricant for bearings/guiding rails and go over the lengths of the rails again.

4.1.2.7 Emptying the compressed air filter on machines without a POT

Check the filter regularly for compressed air and empty it, if necessary. To do so, remove the front cover (two screws) and lift out the front panel.

4.1.2.8 Filling up oil supply on machines with a POT

Check the oil level monthly. If the level is below half full, add oil.

4.1.2.9 Cleaning the ADC

In the ADC there are two fiber optic cables left or right with a small lens in front of them. This lens can become dirty due to dust and this can interfere with the accuracy of the depth setting. Therefore this lens needs to be cleaned regularly.

The lens itself is made out of PMMA (commonly described as Plexiglas). This means it is scratch sensitive, so it can only be cleaned in three different ways.

When it is not too dirty, a short burst of compressed air can get rid of the dust.

If the dirt is clogged on the lens, use a lint-free cloth, dampened with warm water.

If it is really dirty, mix some washing liquid with water and use a microfiber cloth to clean it. It can be wiped dry with a lint-free cloth, but do not apply pressure on it because this could scratch the lens.

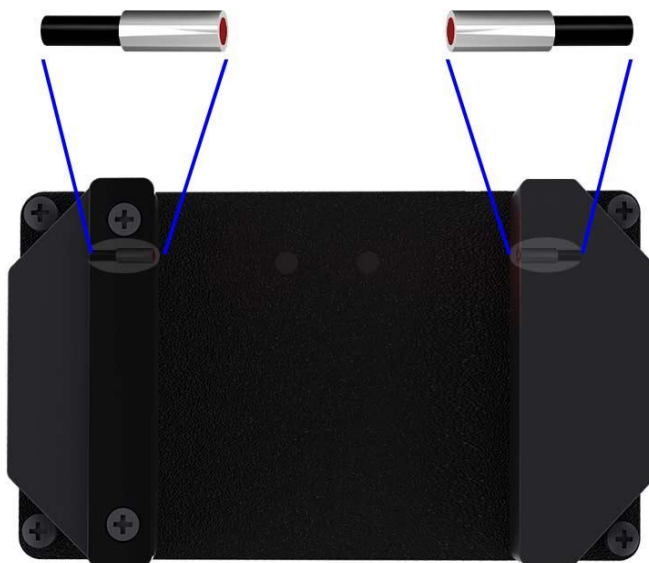

FIG 4-5
ADC CLEANING

4.1.2.10 Cleaning collet of the standard router

Each time a bit is removed or replaced, the collet needs to be cleaned. Clean the collet by tapping it gently on a flat surface and/or blow the dust out of the grooves and thread (in nut and on miller).



FIG 4-6
COLLET MILLER



WARNING: If the collet is not cleaned and the grooves become clogged with dust, the bit can't be secured tightly enough. If the bit then comes loose during routing, it will damage the mats, miller and could even cause injury.

4.1.2.11 Maintenance HF miller

- *TYPES OF HF ROUTER*

There are two models HF spindle motor. The type (or model) is printed on the spindle (see figure). The earlier models were type 4041, the newer models are type 5045.

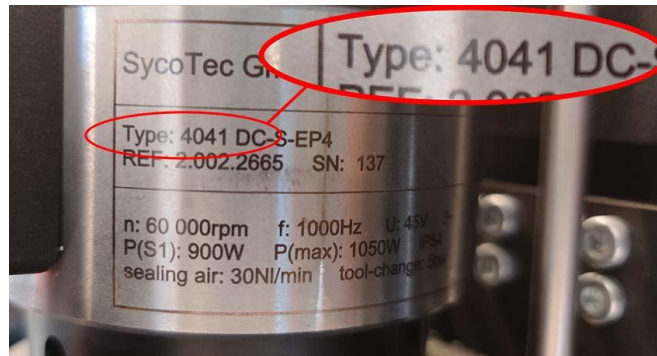

Although they look very similar at first sight, they can easily be told apart. The newer models have “Summa” printed on the red-coloured part of the spindle and have a black ring just under the silver-coloured part.



WARNING: Never close the collets without a (dummy) bit installed as this would damage the collet.



WARNING: Do not install the miller of type 5045 if there is no black ring installed under the red-coloured part. Doing so will damage your F series table cutter.



5045



4041

- *RUN- IN CYCLE*

The miller must go through a run-in procedure at first installation and each time it has run less than 20 minutes in 3 weeks. An internal parameter registers how long and when the miller has run. If a run-in procedure is necessary, Axis Control will display a message and an extra button will be visible in the Modules menu.

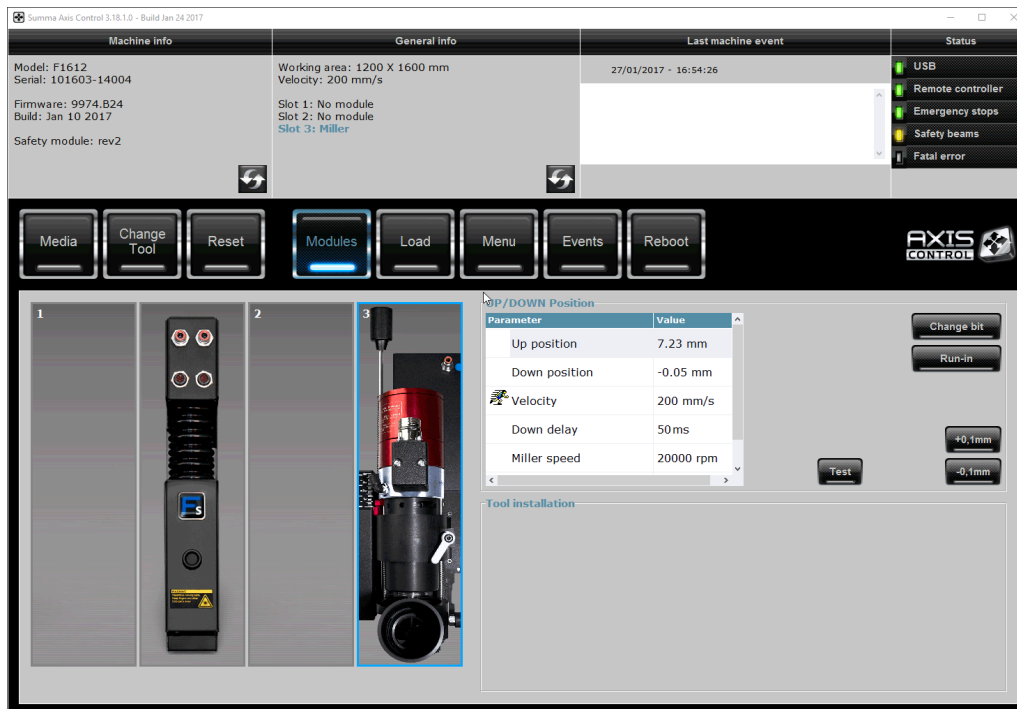
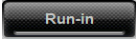

FIG 4-7
MODULES MENU HF MILLER WITH BURN-IN BUTTON

Click the  button and wait for the procedure to finish. A window with the progress of the run-in cycle will be visible. After it is finished, the button in the menu will disappear.

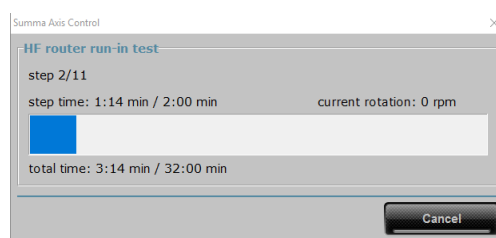

FIG 4-8
WINDOWS RUN-IN CYCLE





NOTE: It is recommended to do a short run-in cycle for the 5045 miller. This run-in cycle is much shorter than the standard run-in cycle and can also be done with Axis Control.

- *REPLACING/CLEANING THE COLLET FOR THE 4041 MODEL*

The miller is shipped with a dummy collet (without space for inserting a routing bit). For the first installation, this dummy collet must be removed and replaced by the 6 mm collet. The same procedure applies for changing a standard collet.

3. Ensure the HF miller is at a complete standstill.



4. Click , then click the router module image and click .

5. Remove the HF miller unit from the router module and place it on the conveyor belt, making sure to set the spindle down in a stable position.

6. Switch the router module's rear switch to the "open" position to apply compressed air to the HF router.

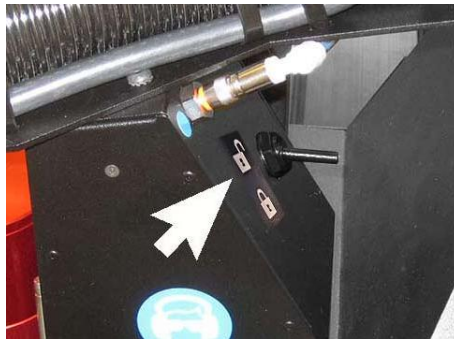

FIG 4-9
SWITCH FOR BIT CHANGE

7. Remove the bit from the collet.
8. Inside the collet there is a set screw to secure the collet. **Verify that it is not screwed in too far. Use an Allen key to loosen the set screw.**



FIG 4-10
COLLET WITH SETSCREW

9. Manually rotate the collet in the green-arrow direction and remove it.



FIG 4-11
REMOVING COLLET FROM THE MILLER



WARNING: If the collet cannot be loosened by hand, carefully loosen it using the provided 10 mm and 13 mm wrenches, turning strictly in the loosening direction.

10. Either take a new collet or clean the collet thoroughly with one of the brushes provided with the miller motor. Make sure the inside, outside, and slots are free of dust and debris.



FIG 4-12
CLEANING THE COLLET



NOTE: It is advised to clean the collet several times per week in heavy-use environments, or whenever tool changes are frequent.

11. If necessary, apply a light film of oil to the collet thread.
12. Use an Allen key to ensure the screw is only just visible in the hole (black arrow).



13. Insert a bit or dummy bit in the collet.



WARNING: Never close or tighten a collet without a bit or dummy bit inserted, as this may cause permanent deformation.

14. Insert the collet into the spindle and screw it in by hand in the black-arrow direction until the mechanical resistance point is reached.
15. Once at the stop, rotate the collet one-quarter turn counter-clockwise (green-arrow direction) to set the correct clamping stroke.



FIG 4-13
RE-INSTALL THE COLLET FROM THE MILLER



WARNING: If the collet is screwed in too far, irreversible spindle damage may occur. If it is not screwed in far enough, the routing bit can loosen during operation, potentially damaging the workpiece, the table, or causing operator hazard.

16. Remove the dummy bit or bit to gain access to the set screw.
17. Using the Allen wrench, tighten the set screw with 1.0–1.5 Nm torque to secure the collet against twisting.
18. Reinsert the bit.



WARNING: Never close or tighten a collet without a bit or dummy bit inserted, as this may cause permanent deformation.

19. Stop the compressed air supply by flipping the switch on the back of the router module to the “closed” position.
20. Reposition the spindle in the router module.
21. Press “online” in axis control.

- *REPLACING/CLEANING THE COLLET FOR THE 5045 MODEL*

The miller is shipped with a dummy collet (without space for inserting a routing bit). For the first installation, this dummy collet must be removed and replaced by the 6 mm collet. The same procedure applies for changing a standard collet.

1. Ensure the HF miller is at a complete standstill.



2. Click , then click the router module image and click .

3. Remove the HF miller unit from the router module and place it on the conveyor belt, making sure to set the spindle down in a stable position.

4. Switch the router module's rear switch to the "open" position to apply compressed air to the HF router.

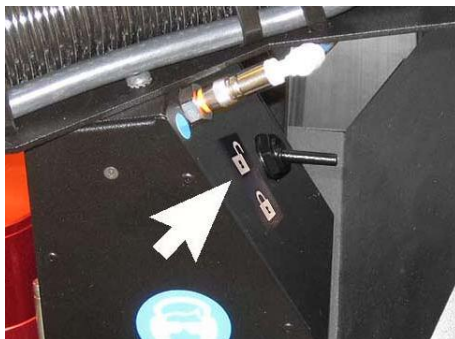

FIG 4-14
SWITCH FOR BIT CHANGE

5. Remove the bit from the collet.
6. Manually rotate the collet in the green-arrow direction and remove it.



FIG 4-15
REMOVING COLLET FROM THE MILLER



WARNING: If the collet cannot be loosened by hand, use a ring tool to loosen the collet by turning strictly in the loosening direction.

7. Either take a new collet or clean the collet thoroughly with one of the brushes provided with the miller motor. Make sure the inside, outside, and slots are free of dust and debris.



NOTE: It is advised to clean the collet several times per week in heavy-use environments, or whenever tool changes are frequent.

8. If necessary, apply a light film of oil to the collet thread.
9. Insert a bit or dummy bit in the collet.



WARNING: Never close or tighten a collet without a bit or dummy bit inserted, as this may cause permanent deformation.

10. Insert the collet into the spindle and screw it in by hand in the black-arrow direction (see fig.4-16 below) until the mechanical limit stop is reached.
11. Tighten with 0.2 – 0.5 Nm torque using the ring tool.

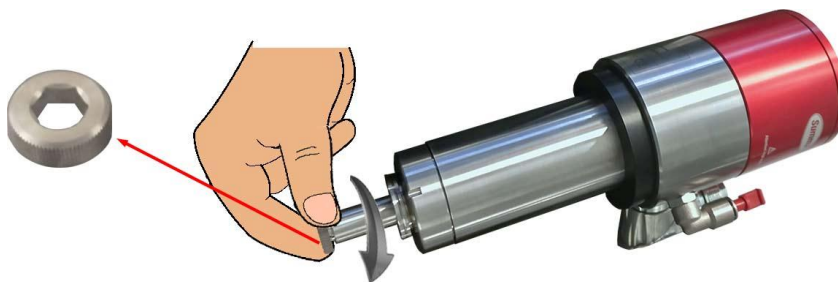

FIG 4-17
RE-INSTALL THE COLLET FROM THE MILLER



WARNING: If the collet is screwed in too far, irreversible spindle damage may occur. If it is not screwed in far enough, the routing bit can loosen during operation, potentially damaging the workpiece, the table, or causing operator hazard.

12. Stop the compressed air supply by flipping the switch on the back of the router module to the “closed” position.
13. Reposition the spindle in the router module.
14. Press “online” in axis control.

5 INCLUDED ACCESSORIES

The following accessories are included in the purchase of your F-series cutter:

5.1.1.1 F1432 (EU)

Part number	Part description	Included
F1432-42	Cutting table (working area 137 x 320 cm)	1
	Vacuum pack: 1 pump 2.3kW, sound absorber, switching valve	1
	Conveyor system with 3 pneumatic media clamps and roll-support	1
	Integrated safety system	1
	Camera system	1
	Drag module	1
	ADC left & right	1
	GoProduce	1
Standard power requirements: 3 x 400V+N		

5.1.1.2 F1432 (US)

Part number	Part description	Included
F1432-41	Cutting table (working area 54 x 126 inch)	1
	Vacuum pack: 1 pump 2.55kW, sound absorber, switching valve	1
	Conveyor system with 3 pneumatic media clamps and roll-support	1
	Integrated safety system	1
	Camera system	1
	Drag module	1
	ADC left & right	1
	GoProduce	1
Standard power requirements: 3 x 208V+N / 60Hz		

5.1.1.3 F1612 (EU)

Part number	Part description	Included
F1612-42	Cutting table (working area 160 x 120 cm)	1
	Vacuum pack: 1 pump 1.3kW, sound absorber, switching valve	1
	Conveyor system with 3 pneumatic media clamps and roll-support	1
	Integrated safety system	1
	Camera system	1
	Drag module	1
	ADC left & right	1
	GoProduce	1
Standard power requirements: 3 x 400V+N		

5.1.1.4 F1612 (US)

Part number	Part description	Included
F1612-41	Cutting table (working area 63 x 47 inch)	1
	Vacuum pack: 1 pump 1.75kW, sound absorber, switching valve	1
	Conveyor system with 3 pneumatic media clamps and roll-support	1
	Integrated safety system	1
	Camera system	1
	Drag module	1
	ADC left & right	1
	GoProduce	1
Standard power requirements: 3 x 208V+N / 60Hz		

5.1.1.1 F1612 (US) Single Phase

Part number	Part description	Included
F1612-43	Cutting table (working area 63 x 47 inch)	1
	Vacuum pack: 1 pump 1.75kW, sound absorber, switching valve	1
	Conveyor system with 3 pneumatic media clamps and roll-support	1
	Integrated safety system	1
	Camera system	1
	Drag module	1
	ADC left & right	1
	GoProduce	1
Standard power requirements: 1 x 240V+N / 60Hz		

5.1.1.1 F1625 (EU)

Part number	Part description	Included
F1625-42	Cutting table (working area 160 x 250 cm)	1
	Vacuum pack: 2 pumps 1.3kW, sound absorber, switching valve	1
	Conveyor system with 3 pneumatic media clamps and roll-support	1
	Integrated safety system	1
	Camera system	1
	Drag module	1
	ADC left & right	1
	GoProduce	1
Standard power requirements: 3 x 400V+N		

5.1.1.2 F1625 (US)

Part number	Part description	Included
F1625-41	Cutting table (working area 63 x 98 inch)	1
	Vacuum pack: 2 pumps 2kW, sound absorber, switching valve	1
	Conveyor system with 3 pneumatic media clamps and roll-support	1
	Integrated safety system	1
	Camera system	1
	Drag module	1
	ADC left & right	1
	GoProduce	1
Standard power requirements: 3 x 208V+N / 60Hz – 30A		

5.1.1.3 F1832 (EU)

Part number	Part description	Included
F1832-42	Cutting table (working area 184 x 320 cm)	1
	Vacuum pack: 2 pumps 2.3kW, sound absorber, switching valve	1
	Conveyor system with 6 pneumatic media clamps and roll-support	1
	Integrated safety system	1
	Camera system	1
	Drag module	1
	ADC left & right	1
	GoProduce	1
Standard power requirements: 3 x 400V+N		

5.1.1.4 F1832 (US)

Part number	Part description	Included
F1832-41	Cutting table (working area 72 x 126 inch)	1
	Vacuum pack: 2 pumps 2.55kW, sound absorber, switching valve	1
	Conveyor system with 6 pneumatic media clamps and roll-support	1
	Integrated safety system	1
	Camera system	1
	Drag module	1
	ADC left & right	1
	GoProduce	1
Standard power requirements: 3 x 208V+N / 60Hz		

5.1.1.5 F3220 (EU)

Part number	Part description	Included
F3220-42	Cutting table (working area 327 x 210 cm)	1
	Vacuum pack: 2 pumps 2.3kW, sound absorber, switching valve	1
	Conveyor system with 6 pneumatic media clamps and roll-support	1
	Integrated safety system	1
	Camera system	1
	Drag module	1
	ADC left & right	1
	GoProduce	1
Standard power requirements: 3 x 400V+N		

5.1.1.6 F3220 (US)

Part number	Part description	Included
F3220-41	Cutting table (working area 128 x 82 inch)	1
	Vacuum pack: 2 pumps 2.55kW, sound absorber, switching valve	1
	Conveyor system with 6 pneumatic media clamps and roll-support	1
	Integrated safety system	1
	Camera system	1
	Drag module	1
	ADC left & right	1
	GoProduce	1
Standard power requirements: 3 x 208V+N / 60Hz		

5.1.1.7 F3232 (EU)

Part number	Part description	Included
F3232-42	Cutting table (working area 327 x 320 cm)	1
	Vacuum pack: 2 pumps 2.3kW, sound absorber, switching valve	1
	Conveyor system with 6 pneumatic media clamps and roll-support	1
	Integrated safety system	1
	Camera system	1
	Drag module	1
	ADC left & right	1
	GoProduce	1
Standard power requirements: 3 x 400V+N		

5.1.1.8 F3232 (US)

Part number	Part description	Included
F3232-41	Cutting table (working area 128 x 126 inch)	1
	Vacuum pack: 2 pumps 2.55kW, sound absorber, switching valve	1
	Conveyor system with 6 pneumatic media clamps and roll-support	1
	Integrated safety system	1
	Camera system	1
	Drag module	1
	ADC left & right	1
	GoProduce	1
Standard power requirements: 3 x 208V+N / 60Hz		

TOOLS &
APPLICATION
OVERVIEW

Recommended Alternative	Tangential Module																											
	Drag Module	Standard Routing Module	HF Routing Module	High Torque Rotary Module	Kiss Cut Tool + 390-534 knife	Kiss Cut Tool+ 390-560 knife	Kiss Cut Tool + 390-550 knife	Single Edge Cut-out tool 500-9312	Bevel Cut knife	Double Edge Cut-out Tool 500-9311	Heavy Duty Cutout Tool 500-9314	Corrugated Tool	EDT Tool 500-9320	POT Tool 500-9350	POT-L Tool 500-9358	Perforating Tool 500-9315	V-Cut Tool 0° 500-9340	V-Cut Tool 15° 500-9341	V-Cut Tool 22.5° 500-9342	V-Cut Tool 30° 500-9343	V-Cut Tool 45° 500-9344	Creasing Tool D25 R3 W8 500-9325	Creasing Tool D25 R1,5 W8 500-9326	Creasing Tool D25 R0,75 W1,5 500-9327	Creasing Tool D15 R0,35 W0,7 2pt 500-9328	Creasing Tool D15 R0,17 W0,35 1 pt 500-9329	Creasing Tool 500-9313	500-9324
CARDBOARD MATERIALS																												
Paper < 200 gsm																												
Cardboard 300-500 gsm																												
Corrugated B flute (3 mm)																												
Corrugated C flute (4 mm)																												
Corrugated BC flute (7 mm)																												
Corrugated E flute (1.5 mm)																												
Honeycomb board < 10 mm																												
Honeycomb board >= 10 mm															*													
ROLL MATERIALS																												
Adhesive vinyl																												
Adhesive PVC banner vinyl																												
PVC Banner																												
Mesh Banner																												
Sandblast material																												
Reflective sheeting																												
Window film																												
Magnetic																												
SYNTHETIC MATERIALS																												
Corrugated PP board <= 5 mm																												
Corrugated PP board > 5 mm																												
Expanded PVC board <= 2 mm																												
Expanded PVC board > 2 mm																												
Polypropylene sheets <= 1.2 mm																												
Polycarbonate <= 0.6 mm																												
Polycarbonate > 1 mm																												
Plexi																												
PET < 1.2 mm																												
PET < 2 mm																												
COMPOSITES																												
Foamcore with paper liner																												
Foamcore with HIPS liner																												
Foamcore with PVC liner																												
ACP/ACM																												
WOOD																												
MDF																												
Plywood																												
Natural Hardwood																												
TEXTILES																												
Uncoated woven polyester																												
Coated woven polyester																												
Laminated Fabrics																												
Canvas																												
INDUSTRIAL MATERIALS																												
Varnish blankets																												
Gasket																												
Insulation foam																												
Textiles (Coated-Uncoated)																												
Rubber																												

* min. thickness 20 mm

More info on www.summa.com | [#summafinish](https://twitter.com/summafinish)

