

Summa / **valiani**
your perfect cut

OMNIA

Instruction and Maintenance
Manual

SUMMARY

1	PREFACE.....	1
1.1	TO ENSURE PROPER AND SAFE USE.....	1
1.2	CONVENTIONS USE IN THIS MANUAL	1
1.3	SAFETY PRECAUTIONS (NOTE)	1
1.4	SAFETY PRECAUTIONS (DANGER).....	2
1.5	SAFETY PRECAUTIONS (CAUTION)	3
1.6	CEE REGULATION	3
1.7	NOTE ABOUT THIS MANUAL	4
1.8	SCOPE OF THE INSTRUCTION MANUAL	4
1.9	INFORMATION REGARDING TECHNICAL ASSISTANCE.....	4
1.10	WARRANTY CONDITIONS	5
1.11	GENERAL INFORMATION	5
1.12	TRADEMARKS.....	5
1.13	COPYRIGHT	5
2	WARNINGS	6
2.1	LABELS PRESENT ON THE MACHINE	6
2.2	DETAILS OF THE VARIOUS LABELS	7
2.3	SAFETY EQUIPMENT FITTED TO THE MACHINE	8
2.4	OPERATOR SAFETY MEASURES	10
2.5	OTHER RISKS	10
3	INTRODUCTION.....	10
3.1	MACHINE DESCRIPTION	10
3.2	CUTTING TOOLS	12
3.3	PEN PLOTTING TOOL (OPTIONAL)	14
3.4	CREASING TOOL (OPTIONAL)	14
3.5	MULTI-WALL CREASING TOOL – BROWN Ø60 (OPTIONAL).....	15
3.6	VERSATOOL (OPTIONAL).....	15
3.6.1	<i>Interchangeable cutting heads (Optional)</i>	<i>16</i>
3.6.2	<i>SCORING / CREASING TOOLS (OPTIONAL)</i>	<i>17</i>
3.7	TECHNICAL DATA	18
3.8	PROPER USE OF THE MACHINE	18
3.9	IMPROPER USE OF THE MACHINE	19
3.10	BEFORE USE.....	19
4	CONTROLS DESCRIPTIONS AND PREPARATION FOR USE	20
4.1	EMERGENCY BUTTONS	20
4.2	POWER ON SWITCH	21
4.3	STARTING THE VACUUM PUMP AND SELECTING THE SUCTION ZONES	21
4.4	LOADER CONTROLS.....	21
4.5	MATERIAL PICK-UP ROLLER.....	22
4.6	DESCRIPTION OF SIGNAL LIGHTS.....	22
4.7	PREPARING FOR USE	23
4.7.1	<i>Positioning the material on the loader table</i>	<i>24</i>
4.7.2	<i>Switching on the vacuum pump.....</i>	<i>27</i>
4.7.3	<i>Tangential tool preparation.....</i>	<i>28</i>
4.7.4	<i>Oscillating cutting tool preparation (optional)</i>	<i>29</i>
4.7.5	<i>X type oscillating tool preparation (optional)</i>	<i>30</i>
4.7.6	<i>PREPARING THE KISS-CUT TOOL (OPTIONAL)</i>	<i>30</i>
4.7.7	<i>Preparing the t-mark tool</i>	<i>31</i>



4.7.8	Preparing the creasing tool.....	31
4.7.9	Fitting a cutting blade versatool (optional)	32
4.7.10	Repalcyng the foot/roller on white head - versa tool (optional).....	32
4.7.11	Head access.....	34
4.7.12	Mounting tool.....	34
4.7.13	Assembling the versatool head.....	36
4.7.14	Disassembling the versatool head	36
5	ADJUSTMENTS	37
5.1	ADJUSTING CUTTING AND CREASING DEPTH	37
5.2	REGULATING THE VERSATOOL CUTTING DEPTH	37
5.2	ADJUSTING THE CUTTING PRESSURE OF THE KISS-CUT TOOL	38
5.3	ADJUSTING THE DOWN PRESSURE OF THE CUTTING HEAD	39
5.4	ADJUSTING THE UNLOADING CHUTE INCLINATION.	39
6	ROUTINE MAINTENANCE	40
6.1	CLEANING.....	40
6.2	LUBRIFICATION	41
6.3	PNEUMATIC SYSTEM MAINTENANCE (EVERY 1-2 MONTHS)	42
6.4	REPLACING THE CONVEYOR BELT.....	43
7	TROUBLE SHOOTING	46
7.1	CONNECTION PROBLEMS.....	46
8	DECOMMISSIONING AND DISMANTLING	47
8.1	HAZARDOUS SITUATIONS	47
9	DOCUMENTATION SUPPLIED WITH THE MACHINE.....	47
10	WARRANTY	48
11	DECLARATION OF CONFORMITY.....	49
12	EXTERNAL DIMENSION.....	50



1 PREFACE

Thank you for choosing Omnia. The Omnia has been designed for automatic feeding of the material to be processed and to carry out cutting and creasing for packaging boxes. Brushless motors and continuous cycle processing make it the most effective solution for medium and large runs.

To ensure high cutting quality and optimal productivity, be sure to read this User Manual thoroughly prior to use.



CAUTION! The device is for professional use and not for domestic use.

1.1 TO ENSURE PROPER AND SAFE USE

- To ensure the safe and correct usage of your machine, please read this manual carefully before use.
- After reading this manual keep it in a handy place for quick consultation if necessary.
- Do not allow children to touch, or be near, the machine.
- The following symbols/icons describe important points to safely operate the machine. Please ensure that our safety and general operating instructions are strictly followed.

1.2 CONVENTIONS USE IN THIS MANUAL

To ensure safe and accurate usage of the machine, as well as to prevent injury to persons and property, the security measures contained in this manual are classified in three categories as described below. Be sure to get a full understanding of the difference between each of the categories before reading the manual.

 Note	These are warnings to guide and optimize actions by the operator, or to better highlight the particular characteristics of the machine.
 Danger	This category provides information that, if ignored, could result in serious injury to the operator.
 Caution	This category provides information that, if ignored, could result in injury to the operator and/or damage to the machine.

1.3 SAFETY PRECAUTIONS (NOTE)













Note

When using the cutting tool, take care not to set the blade deeper than necessary. An overly deep blade set-up might damage the conveyor belt and adversely affect the cutting quality.

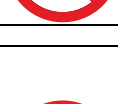









1.4 SAFETY PRECAUTIONS (DANGER)

 Danger	
Do not touch the rollers or moving parts such as the carriage while cutting or plotting is in progress. Such action may result in injury	
Be sure to ground the earth terminal. If the cutting plotter is not grounded, the operator could suffer an electric shock in the event of current leakage.	
Keep your hands, hair, etc., away from the rollers or moving parts such as the carriage even if the machine is stopped, as it may suddenly start moving when data is received. Such action may result in injury.	
Do not disassemble, repair, or modify the machine. Such actions may result in an electric shock or create a fire hazard due to current leakage. Contact with the high-voltage parts within the cutting plotter may also cause an electric shock. If the machine requires repairs, please contact your sales representative or your nearest Valiani vendor for advice.	
Do not connect the machine to a non-rated power supply. The use of a different supply voltage may result in an electric shock or create a fire hazard due to current leakage.	
Do not use the machine in a location where it might be exposed to water, rain, or snow. Such locations may cause electric shock or create a fire hazard due to current leakage.	
If the machine generates smoke, overheats, emits a strange odor, or otherwise functions abnormally, do not continue using it. Turn off the power and unplug the power cord from the electrical socket. Use of the cutting plotter in such a condition may result in a fire hazard or electric shock. After confirming that smoke is no longer being emitted, contact your sales representative or nearest Valiani vendor for repairs. Never attempt to perform repairs yourself. Repair work by inexperienced personnel is extremely dangerous.	
Do not allow dust or metal scraps to adhere to the power plug. A dirty power plug may result in electric shock or create a fire hazard due to current leakage.	
Do not use the power cord if it is damaged. Use of a damaged cord may result in electric shock or create a fire hazard due to current leakage. Replace the power cord with a new one.	
Be careful when handling the cutting blade. Touching the blade with your bare hands may cause injury. Always wear gloves when handling blades. Do not touch the cutter blade whilst cutting is in progress.	
The machine emits a sound pressure higher than 78 dB (A), for which the use of PPE is required.	



1.5 SAFETY PRECAUTIONS (CAUTION)

 Caution	
Do not use or store the machine in a location exposed to direct sunlight or the direct draft of an air conditioner or heater. Such locations may impair the performance of the cutting plotter.	
Do not use the machine in an excessively dusty or humid location. Such locations may impair the performance of the cutting plotter.	
Do not place any receptacle containing water or other fluid on top of the cutting plotter. Fluid falling inside the cutting plotter could cause electric shock or create a fire hazard due to current leakage.	
Do not use the cutting plotter in a location subject to excessive mechanical vibration or electrical noise. Use in such locations may impair the performance of the cutting plotter.	
When disconnecting the power cord or interface cable, do not pull on the cord/cable. Such action will damage the cord/cable, resulting in a fire hazard or, possibly, an electric shock.	
Do not clean the cutting plotter using volatile solvents such as thinners or benzene. Such actions may impair its performance.	
Provide sufficient space around the cutting plotter so that it does not strike any objects in its vicinity during cutting or plotting. Such contact may cause cutting or plotting to go out of alignment.	

1.6 CEE REGULATION

This manual has been written in accordance with the directions of CEE DIRECTIVE 2006/42/CE as detailed in the machine design definition. User instructions are an integral part of the machine. The criteria used for writing comply with the indications of the EUROPEAN STANDARD EN - 292 and, in particular, the point related to USER INSTRUCTIONS (instructions, general requirements and nature of the instructions).



1.7 NOTE ABOUT THIS MANUAL

No part of this publication may be reproduced, stored in a retrieval system, or transmitted, in any form or by any means, without the prior written permission of Valiani.

- Product specifications and other information contained in this document are subject to change without notice.
- Although every effort is made to provide complete and accurate information, please contact your sales representative or the nearest dealer if you find any incorrect or unclear information or wish to make any other comments or suggestions.
- Valiani assumes no liability for damages resulting from incorrect use of the machine.

This instruction and maintenance manual is essential for the technician who will install and operate the machine for the first time. It also provides all the information needed to properly prepare the operator for using, and performing proper maintenance, on the machine. The instruction and maintenance manual is essentially divided into:

- Cover with the name of the machine
- Summary
- Preface
- Manufacturer's details and machine identification
- Instructions for the transportation, installation and use of the machine
- Machine maintenance instructions

The instructions, drawings, images and documents contained in this manual are of a technical nature and confidential property of the Valiani. They cannot be reproduced in any way, either entirely or in part, without prior written permission from the company.

1.8 SCOPE OF THE INSTRUCTION MANUAL

This instruction manual is an essential part of the machine and its scope is to provide all the information necessary to:

- Safely move a packed, or unpacked, machine.
- Correctly install the machine.
- Safely use the machine
- Safely and correctly carry out machine maintenance.
- Decommission and dismantle the machine with respect to the laws in force and the environment.

The instruction manual should be handled with care, using clean hands, and should not be placed on dirty surfaces. It should be protected from humidity, heat and used carefully so as not to damage its contents. Under no circumstances should any of its contents be removed or modified. Should the manufacturer make any changes to the machine he will provide new documentation if necessary.

1.9 INFORMATION REGARDING TECHNICAL ASSISTANCE

The machine is covered by a guarantee as detailed in general conditions of sale. If, during the guarantee period, there are any faults with the machine or with the way it works the manufacturer will, after identifying the problem, conduct repairs or replace any faulty parts deemed necessary. Unauthorised repairs, or the use of parts not provided by Valiani. (unless specified in writing by Valiani), will render the guarantee void and cancel any responsibility for damage caused by the machine as a consequence of unauthorised repairs or the use of unauthorised parts. For these reasons we strongly advise our clients to always call their sales representative, their nearest vendor or technical assistance department at Valiani for advice.



1.10 WARRANTY CONDITIONS

Valiani guarantees that its products are soundly made and are free of manufacturing defects. For guarantee details please refer to the specific guarantee document supplied with this manual.

1.11 GENERAL INFORMATION

Carefully following the assembly, usage and maintenance standards described in this manual will ensure lasting performance and protect your investment. We suggest that you read and follow the recommendations carefully before machine start-up. We are available to offer any assistance that you may require. Please remember that non-observance of the advice and instructions included in this manual will, or could, result in the loss of warranty. As part of its continuing quality improvement programme VALIANI S.r.l. reserves the right to carry out modifications it believes to be necessary. For further details or any eventual problem, please contact us.

1.12 TRADEMARKS

All trademarks mentioned belong to their owners, third-party brands, product names, trade names, corporate names and companies mentioned herein may be the trademarks of their respective owners or registered trademarks of other companies and have been used for purposes of explanation and the owner's benefit, without implying a violation of copyright law.

1.13 COPYRIGHT

All the material contained in this manual is owned by the vendor and may not be reproduced in full, or in part, without prior written consent from the vendor.



2 WARNINGS

2.1 LABELS PRESENT ON THE MACHINE

The machine is fitted with various labels to show either data or safety concern areas for the operator. Referring to the photograph below these are:

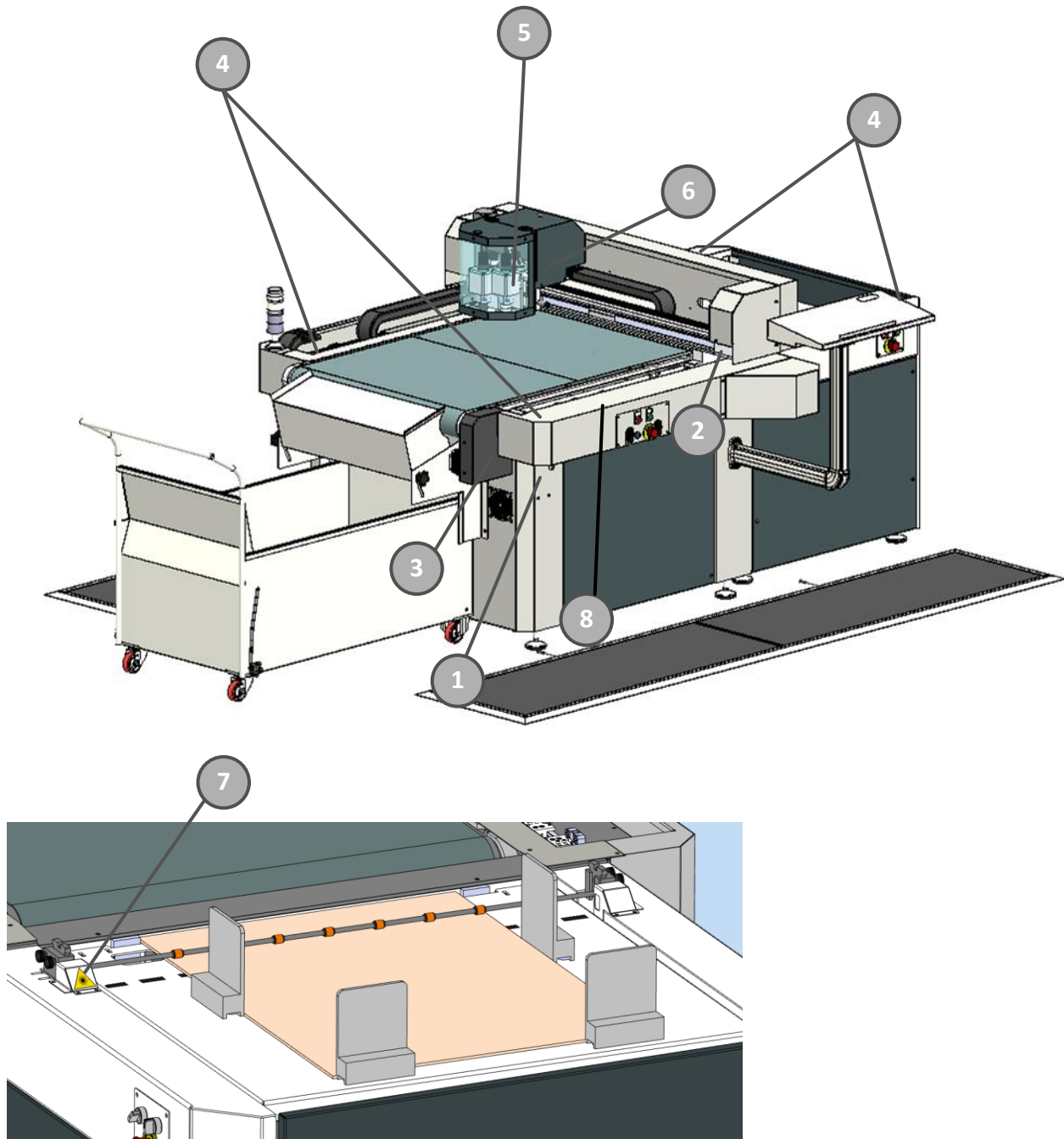

Figure 2-1



2.2 DETAILS OF THE VARIOUS LABELS

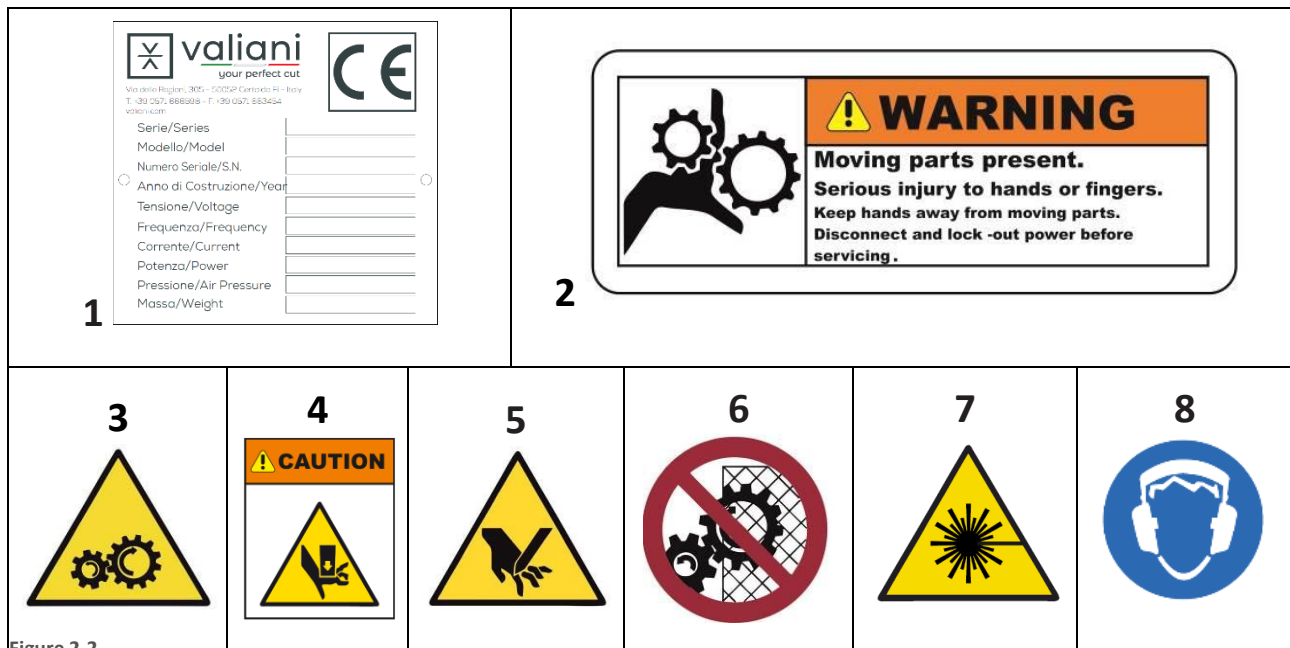

Figure 2-2

- LABEL 1:** Plate showing manufacturer data, model, year, serial number, weight, electrical and pneumatic information of the machine.
- LABEL 2:** Adhesive label: Hand Entanglement / Rotating Gears warning
- LABEL 3:** Adhesive label: Rotating gears warning.
- LABEL 4:** Adhesive label: Moving parts warning.
- LABEL 5:** Adhesive label: Hand cut warning
- LABEL 6:** Adhesive label: Do not remove protection while machine is on.
- LABEL 7:** Adhesive label: Danger from laser beam photocells.
- LABEL 8:** Adhesive label: Wear hearing noise protection.



2.3 SAFETY EQUIPMENT FITTED TO THE MACHINE

The machine is equipped with various safety devices and an emergency stop button, to the drivetrain, that protects the operator from possible injury resulting from contact with moving parts. Two types of safety protection are provided:

The safety devices fitted on the machine are as follows:

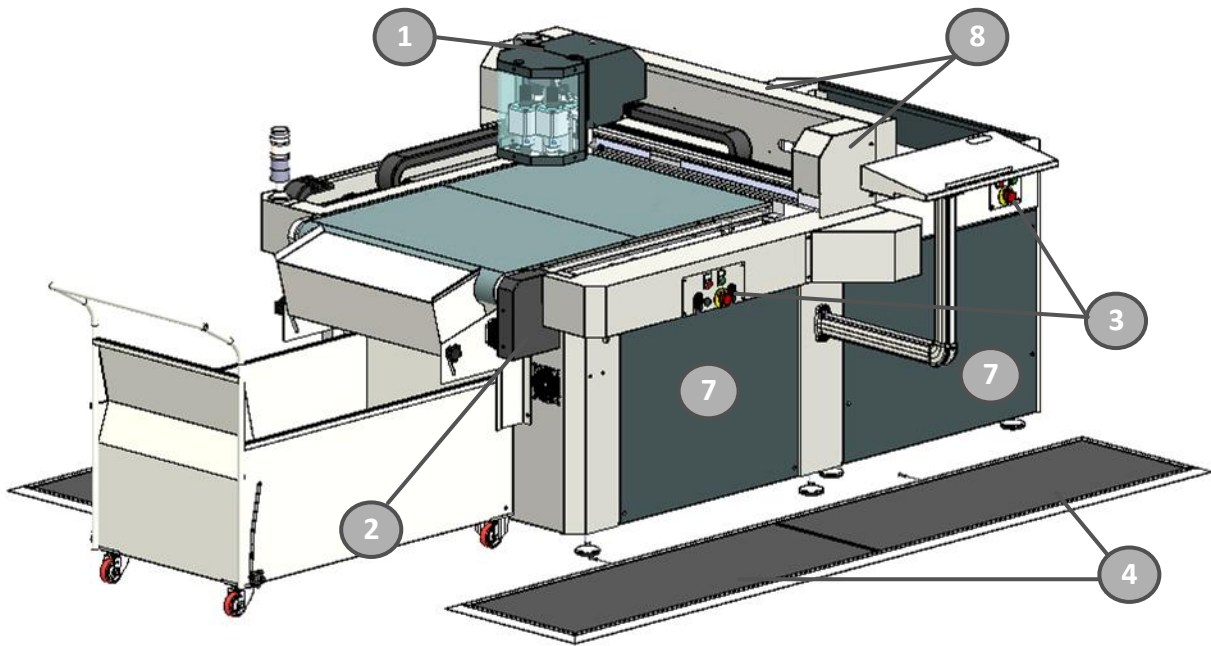

Figure 2-3

- 1 Openable cutting head guard (fixed protection - mounted with screws).
- 2 Motor protection (fixed guards mounted with screws).
- 3 Emergency button (see paragraph 6 of this manual).
- 4 Optional operator safety mats (fixed to the floor with screws).



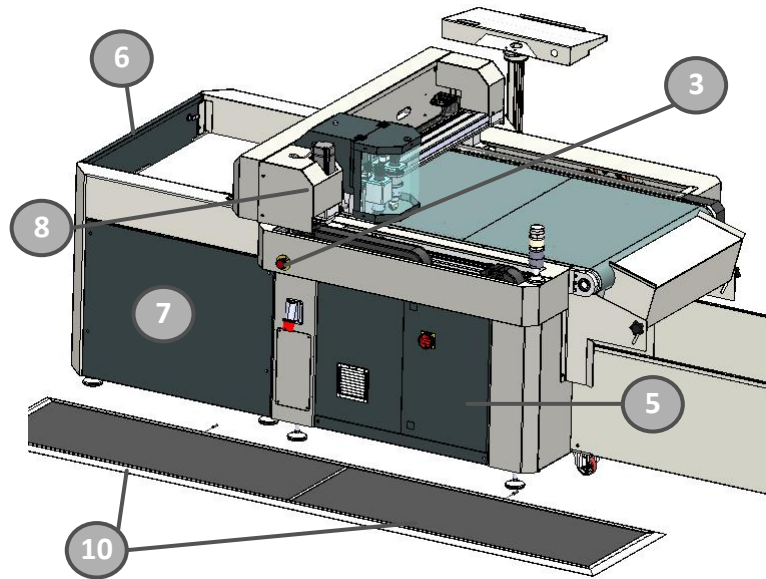

Figure 2-4

- 5 Electrical panel door (mobile guard closed with a key).
- 6 Feeder inspection door (mobile guard closed with a key).
- 7 Side inspection panels (fixed guards mounted with screws).
- 8 Mobile beam guards (fixed guards mounted with screws).
- 9 Fixed fence (assemble on the machine)
- 10 OPTIONAL: Safety mats (fixed on the floor with screws in place of the fixed fence (9)).

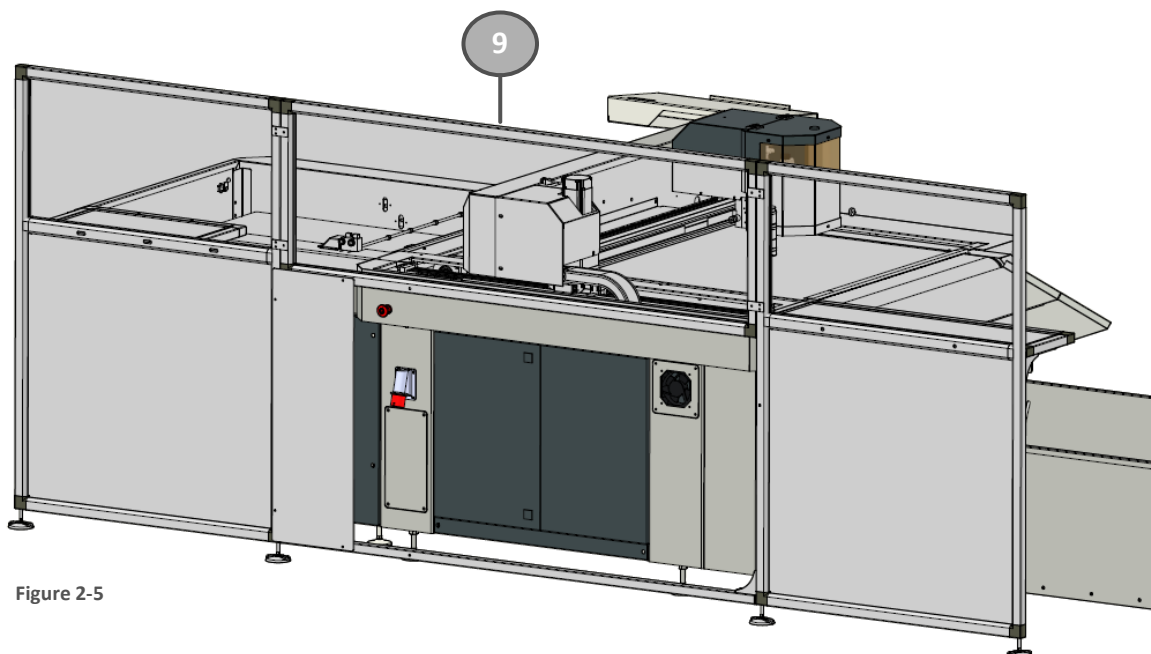

Figure 2-5



DANGER! Before switching the machine on, please check that all the safety covers are closed. Ignoring these precautions could result in serious injury to the operator, to anybody nearby or potentially damage the machine. Under no circumstances use the machine with the mobile safety covers open or the fixed covers removed



2.4 OPERATOR SAFETY MEASURES

According to the type of work conducted with the machine some maintenance work will require the operator to wear gloves and safety glasses.

While servicing the machine, it is recommended to use personal protective equipment:

- Gloves while cleaning the machine;
- Gloves with any operation involving the tools, cutting blades.
- Safety glasses while performing maintenance and inspection of the compressed air system.

2.5 OTHER RISKS

This section has the scope of identifying the other risks associated with using the machine so that operators can identify situations in which they should take particular care when doing specific tasks.

- During installation take the outmost care when positioning the machine on its base, where there could be a risk of you losing your balance and dropping the work table. Only people directly involved in the assembly operation should be allowed into the assembly area.
- Be very careful; to avoid possible injury due to the incorrect handling of the blades and the cutters while performing any tasks on the tool or on the blade itself, always wear safety gloves.
- To avoid possible injury to hands or fingers do not to place your hands on the worktable, under the cutting head carriage or the cutting head while the machine is working.
- Wait for at least a minute after switching the machine off before opening the electrical box for maintenance so that any residual electrical energy has had time to dissipate.
- Even if the machine is stopped the "EMERGENCY" button must be pressed to put the machine into "suspend mode" before doing any maintenance work (including adjustments).



NOTE! Before doing any maintenance to the electrical system the operator must read this manual and refer to the circuit diagrams provided.



NOTE! This equipment has been tested and found to comply with the limits for a Class A digital device, pursuant to part 15 of the FCC Rules. These limits are designed to provide reasonable protection against harmful interference when the equipment is operated in a commercial environment. This equipment generates, uses, and can radiate radio frequency energy and, if not installed and used in accordance with the instruction manual, may cause harmful interference to radio communications. Operation of this equipment in a residential area is likely to cause harmful interference in which case the user will be required to correct the interference at his own expense.

3 INTRODUCTION

Omnia has been designed for the automatic execution of contour cutting on various supports. Through an automatic loader the sheets are loaded and pulled into the cutting area, all thanks to a suction cup pick-up system. The feeder can hold up to 600 sheets, depending on the thickness. Once in place, the camera will detect the crop marks and start the work cycle, after which the sheets will be unloaded into the collection tray.

The software can control a wide variety of workflow options, including the cutting of files from various graphic design software, QR Code mode and unprinted material. Omnia is perfect for cardboard die-cutting projects, including packaging, business cards and kiss-cuts. With its robust design, it is even capable of processing heavy materials such as corrugated cardboard, pressed cardboard and plastic sheets.

3.1 MACHINE DESCRIPTION

The Omnia consists of a loader, the machine that performs the processing and an unloader to be assembled on site for easier transportation (see paragraph **Error! Reference source not found.**). The depth of the cutting blade can be easily a



OMNIA

adjusted by turning the knob on the head. The software guides the operator through the operations necessary for adjusting the cutting depth.

Once positioned in the loader (1) the material to be processed will be automatically picked up by suction cups (2) and deposited by them on the conveyor belt (3) which will move it to the work area. When in position the material will be blocked by the suction from the worktable and a camera (OPTICROP) (4) prepared for the recognition of the print crop marks and allow, through the software, the identification of the sheet and the creation of cuts and creases on pre-printed materials. Once the cutting and / or creasing cycle is finished, the material will be released, and the belt will transport it to the unloading chute (5) and from there to the collection trolley (6)

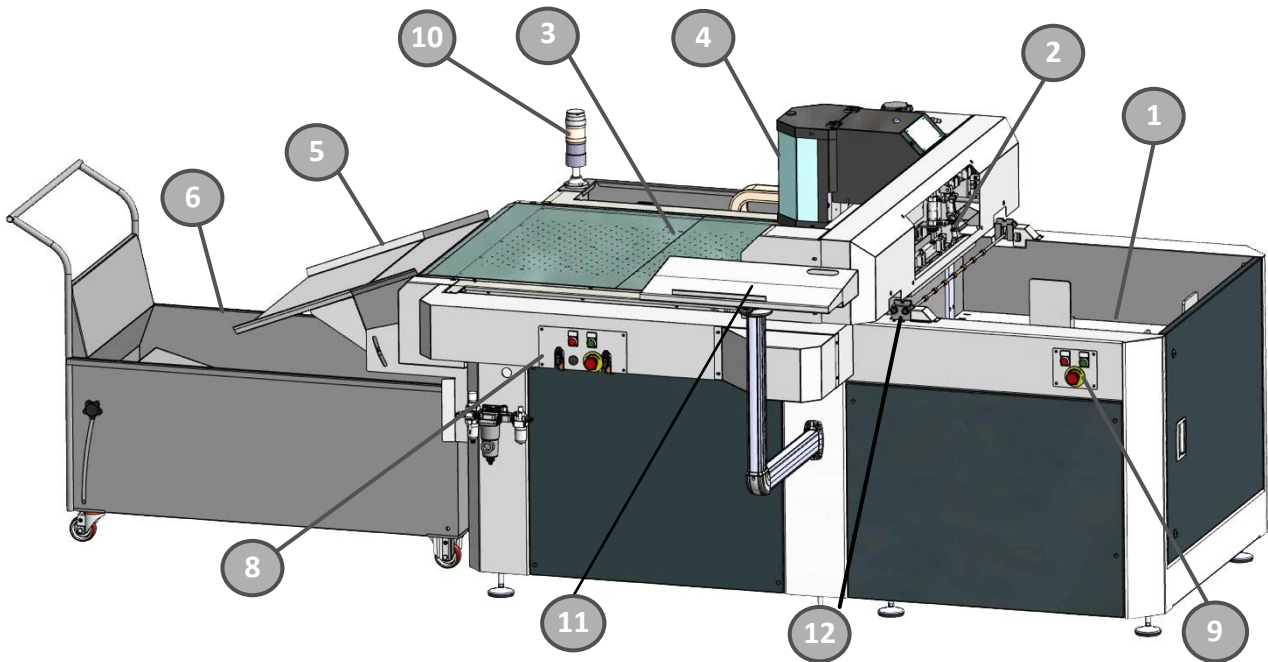

Figure 3-1



3.2 CUTTING TOOLS

The machine can use three tools that allow a greater variety of cuts, types of workable materials

Grey – Tangential Drag Knife (included): The tangential cutting tool allows you to cut a wide variety of materials with a maximum thickness of 5mm (0.196”). The use of drag knife allows you to perform cuts even at high speed.

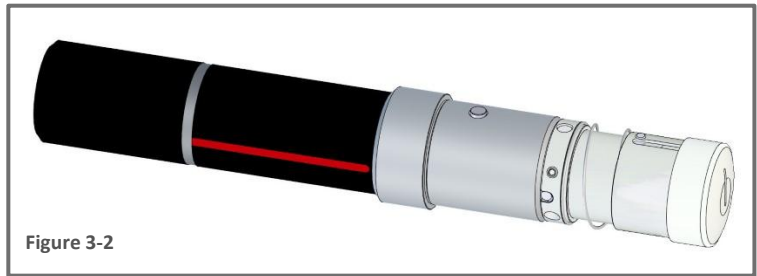

Figure 3-2

Depending on the blade holders and the kind of job the machine is supposed to perform the following blade might be available:

	Code	Description	Fields of use
	L100	Multipurpose Blade. 50° Angle	Universal knife for materials such as paper, cardboard, thin plastic, soft PVC, Foam Board.
	L100B	Multi-purpose Blade. 38 ° Angle for a more precise cut on small radius.	Universal knife for materials such as paper, cardboard, thin plastic.
	L1W40	Carbide multipurpose blade for a longer sharpening duration. 50 ° angle.	Long lasting blade ideal for very abrasive materials. (See L100)
	L1W52	Carbide multipurpose blade for a longer sharpening duration and with a 38 ° angle for greater precision on cuts with a reduced radius.	Long lasting blade ideal for very abrasive materials. (See L100B)
	002156	Multipurpose T16 Blade (38° Angle)	Universal knife for soft materials. To make sharp edges.
	002157	Multipurpose T17 Blade, with a tighter angle for greater precision on cuts with a small radius. (25° Angle)	Sole leather, cardboard, thin polyester. To make sharp edges.

Note: For any special need, other blades might be available. Please contact your local Valiani dealer, or the manufacturer for further information.

Black - Oscillating Cutting Knife (Optional): The oscillating cutting tool is operated by compressed air and it is suitable for both soft and rigid materials. The tool reaches a number of 9.000 oscillations per minute (rpm) with a stroke of 8mm (0.315”). Depending on the blade used, it can cut up to 20 mm (0.787”) thick *. Minimum use pressure: 7 Bar

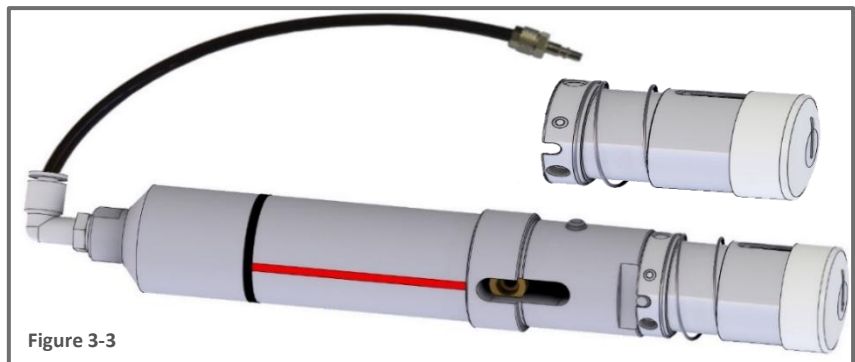

Figure 3-3

* With TC25 Blade.

Depending on the work to be performed, the following blades are available:

	Code	Description	Fields of use
	002720	TC 5mm Blade	Gasket material, solid cardboard, foam cardboard, foamboard with paper surface, foamed materials, soft foam panels, corrugated cardboard, packaging material, honeycomb cardboard.
	001899	TC 10mm Blade	
	001898	TC 15mm Blade	
	001897	TC 25mm Blade	

Note: For any particular need, other blades might be available. Please contact your local Valiani dealer, or the manufacturer for further information.



OMNIA

Black X - Oscillating Cutting Knife - Type X (Optional): The oscillating cutting tool type X is operated by air compressed and it is suitable for soft and thin material. The tool reaches a number of 16.000 oscillations per minute (rpm) with a stroke of 8mm (0.315"). Depending on the blade used, it can cut up to 20 mm thick * Use pressure 8 Bar.

*With 0.64x38mm (0.025"x 1.49") blade.



Figure 3-4

Depending on the work to be performed, the following blades are available:

	Code	Description	Fields of use
	002156	Multipurpose T16 Blade (38° Angle)	Universal knife for soft materials. To make sharp edges.
	002157	Multipurpose T17 Blade, with a tighter angle for greater precision on cuts with a small radius. (25° Angle)	Sole leather, cardboard, thin polyester. To make sharp edges.
	002445	T18 Heavy-Duty Blade	Very rigid materials, sole leather, asbestos free, tang graphite, for thickness up to 5 mm.
	002447	T19 Blade – Soft Rubbers	Soft rubbers up to 12 mm thick.
	002733	T21 Blade – Double Edge HD Blade	

Note: For any special need, other blades might be available. Please contact your local Valiani dealer, or the manufacturer for further information.

Pink – Kiss-Cut Tool (Optional): With mechanically-controlled knife pressure, this tool is specifically designed for kiss-cutting material down to its liner up to 1.2 mm thick.

This tool also includes an adjustable nose piece for precise depth control. Depending on the materials the following blades are available.

	Code	Description	Use
	003110	TK36° blade kit (5pcs)	Standard Tangential Knife 36° - Max cutting thickness 0.25 mm
	003111	TK60° Blade	Tangential Knife 60° - Max cutting thickness 1.2 mm
	003112	36° Double- tip blade	Tangential Double Tip Knife 36° - Max cutting thickness 0.25 mm
	003113	45° Double Wedge Blade	Tangential Knife 45° wedge 40/25° - Max cutting thickness - 1 mm



Figure 3-5



3.3 PEN PLOTTING TOOL (OPTIONAL)

Gold - T-Mark Tool: T-Mark is a tool that allows writing or drawing on the material, creating dynamic drawing or text on the cardboard patterns. The Tool is supplied with a pen cartridge 0.4mm / 0.157" (FISHER pressurized, H=76mm/2.99", Ø4.8mm/1.89", ball 1.1mm/0.43").



Figure 3-6

3.4 CREASING TOOL (OPTIONAL)

Brown – T-Creasing Tool: The Packaging Tools set, consists of one head (Tool holder) with an assortment of creasing wheels of various geometry, which have been designed to process a wide range of materials, for those who need to crease folding cardboard, flute board, corrugated board and coroplast.

Creasing can be performed either in Pressure Mode or Position Mode. In Position Mode, the creasing wheel is lowered to a set depth through the second head's knob and this method is well suited for creasing corrugated carton preventing the breaking of the flute. Pressure Mode is commonly used for folding cardboard; however, a hybrid mode might be needed with other materials.

The various wheels can be exchanged on the head without any additional tools, therefore minimizing delay during the working process.

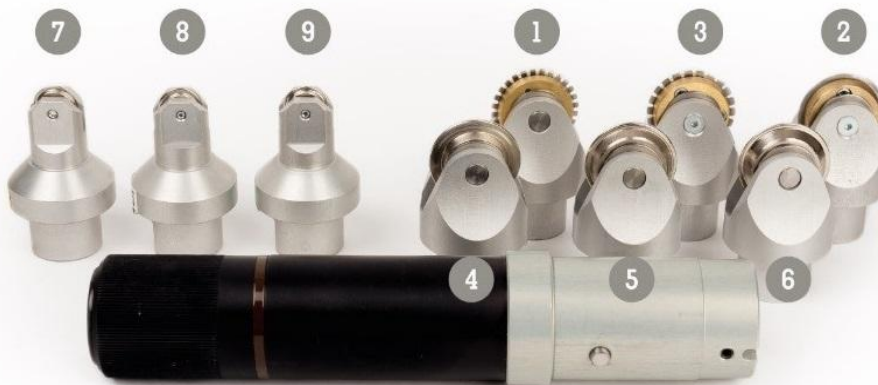

Figure 3-7

The creasing set consists of 9 tools each with different characteristics:

- | | | |
|----|----------------------------------------|------------------------------------------------------------|
| 1. | Perforating tool Ø 32mm /1.26" | Serrated cut wheel, 2-1mm / 0.078-0.039" step. |
| 2. | Cutting tool Ø 32 mm /1.26" | Metal wheel, for Cut-crease |
| 3. | Perforating tool Ø 32 mm /1.26" | Serrated cut wheel, 3-1mm / 0.118-0.039" step. |
| 4. | Creasing Wheel Ø 32 mm /1.26" | 3 pt (1.1mm / 0.043") round crest, Flute F/E |
| 5. | Creasing Wheel Ø 32 mm /1.26" | 4 pt (1.5mm / 0.059") round crest, Flute B/C |
| 6. | Creasing Wheel Ø 32 mm /1.26" | 6 pt (2mm / 0.078") round crest, Flute A/B/Double |
| 7. | Creasing Wheel Ø 16 mm /0.63" | 2 pt (0.7mm / 0.0275") round crest, cardboard 150-300 gsm. |
| 8. | Creasing Wheel Ø 16 mm /0.63" | 3 pt (1.1mm / 0.043") round crest, cardboard 150-300 gsm. |
| 9. | Creasing Wheel Ø 16 mm /0.63" | 4 pt (1.5mm / 0.059") round crest, cardboard 250-400 gsm. |



3.5 MULTI-WALL CREASING TOOL – BROWN Ø60 (OPTIONAL)

Brown – Creasing Wheel Ø60: It consists of a tool holder with a bundle of creasing wheels of various geometries specific for single and multiple flute corrugated cardboards.

Creasing can be performed either in Pressure Mode or Position Mode. In Position Mode, the creasing wheel is lowered to a set depth thru the second head's knob and this method is well suited for creasing corrugated carton preventing to break the flute. Pressure Mode is commonly used for folding cardboard; however, a hybrid mode might be needed with other materials.

The different wheels can be changed from the head without the need of any additional tool, thus minimizing the delay during the work process.

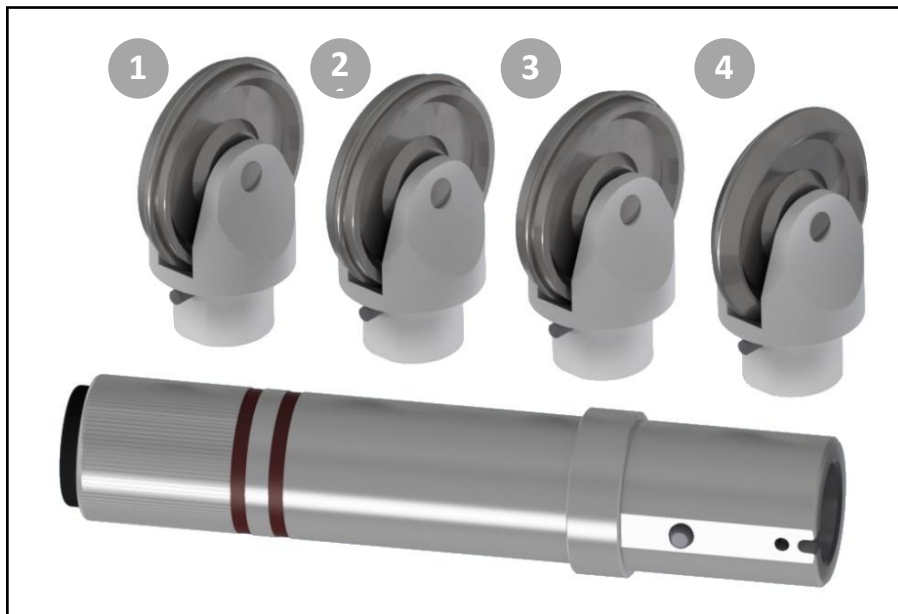

Figure 3-8

There are four types of available wheels upon request, each one with different characteristics:

1. **Creasing Wheel Ø 60 mm:** 3x2mm 8pt (1.1 mm) round crest, Flute type F/E
2. **Creasing Wheel Ø 60 mm:** 3x1.5mm 8pt (1.5 mm) round crest, Flute type B/C
3. **Creasing Wheel Ø 60 mm:** 2x1.5mm 6pt (2 mm) round crest, Flute type A/B/Double
4. **Creasing Wheel Ø 60 mm:** V-Shape for double and triple flute board.

3.6 VERSATOOL (OPTIONAL)

The VersaTool accessory allows the use of instruments of the "i" series (interchangeable), allowing the operator to expand the range of tools available.



Figure 3-9



3.6.1 INTERCHANGEABLE CUTTING HEADS (OPTIONAL)

The VersaTool holder, as mentioned above, can be equipped with a series of interchangeable cutting heads (optional), which allow you to increase the type of cuts, the type of mountboard and the type of materials that can be processed, extending the range of processes available.



Figure 3-10

B - 45° Head (red) for bevel cut: The 45° head (red) cuts from the front of material with an inclination of exactly 45°. The head allows the cutting of all types of mountboard with thicknesses from 0 to 2,2 mm (0,087”).

C - 90° head (grey) for straight cut: This cutting head has been specifically designed for the vacuum table series of machines and benefits from Valiani’s vast experience in the CMC machinery market. Thanks to a wide Teflon foot it guarantees a wider cutting footprint and superior accuracy, especially on thick and hard materials (max 5mm – 3/16”). In combination with a vacuum table it allows the machine to cut to the edge of the material.

D – 40° Head (green) for bevel cut: This head offers ample versatility guaranteeing an excellent quality of cut from the front of materials on all types of mountboard with thicknesses from 0 to 2,2 mm (0,087”). This head gives very good results when cutting curves with little radius and cuts good quality clip art.

E - Embossing head (purple) for pressing in relief: The embossing head is designed for decorating in relief. Whatever design, corner or clip art it can be elegantly pressed in relief on a mountboard by using the pressure of a sphere.

F - 90° Head (white) for straight cut: The 90° head (white) allows both a pass-through cut and a kiss-cut.

Depending on the blade holders and the kind of job the machine is supposed to perform the following blade might be available:

	Code	Description	Fields of use
	L100	Multipurpose Blade. 50°Angle	Universal knife for materials such as paper, cardboard, thin plastic, soft PVC, Foam Board.
	L100B	Multi-purpose Blade. 38 °Angle for a more precise cut on small radius.	Universal knife for materials such as paper, cardboard, thin plastic.
	L1W40	Carbide multipurpose blade for a longer sharpening duration. 50 ° angle.	Long lasting blade ideal for very abrasive materials. (see L100)
	L1W52	Carbide multipurpose blade for a longer sharpening duration and with a 38 ° angle for greater precision on cuts with a reduced radius.	Long lasting blade ideal for very abrasive materials. (See L100B)
	002156	Multipurpose T16 Blade (38° Angle)	Universal knife for soft materials. To make sharp edges.
	002157	Multipurpose T17 Blade, with a tighter angle for greater precision on cuts with a small radius. (25° Angle)	Sole leather, cardboard, thin polyester. To make sharp edges.

Note: For any special need, other blades might be available. Please contact your local Valiani dealer, or the manufacturer for further information.



G - 45° Head (blue) for bevel cut.

The 45° head (blue) is offered for cutting from the backside of materials of all types of mountboard (matboard) and Foamboard with thicknesses of 0 to 5mm (3/16"). The use of this head is recommended for cutting all mountboards (matboards) that have a delicate faceside that could be damaged by a classic front cut. It is also aimed for use with dense matboards with thicknesses of up to 4,4mm (0,173") like museum and conservation boards.

H – Fork The fork is the tool used to manually change the cutting heads and is always supplied with VersaTool.

3.6.2 SCORING / CREASING TOOLS (OPTIONAL)

The VersaTool accessory, as mentioned above, can be equipped with a creasing tool capable to perform creasing and perforating process on packaging materials. The head has the same fastening system as the interchangeable cutting heads and it is supplied with 9 creasers. The system provides for release and quick coupling of each tool making it very versatile.

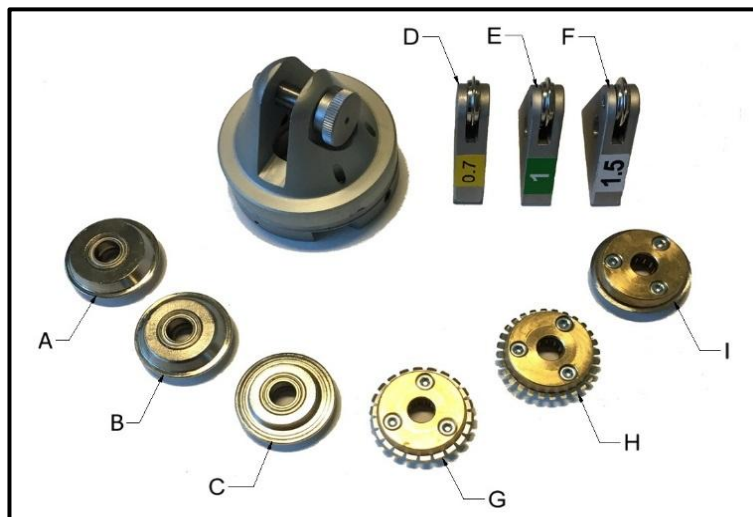

Figure 3-11

The set of tools for creasing consists of 9 tools each with different characteristics:

- A - Scoring tool:** 32mm / 1.26" diameter, 1mm / 0.039" round crest, tool for creasing corrugated cardboard
- B - Scoring tool:** 32mm / 1.26" diameter, 1,5mm / 0.059" round crest, flat board & E flute creasing wheel.
- C - Scoring tool:** 32mm / 1.26" diameter, 2mm / 0.078" round crest, flat board & E flute creasing wheel.
- D - Scoring tool:** 16mm / 0.63" diameter, 0.7mm / 0.0275" round crest, flat board & E flute creasing wheel.
- E - Scoring tool:** 16mm / 0.63" diameter, 1mm / 0.039" round crest, flat board & E flute creasing wheel.
- F - Scoring tool:** 16mm / 0.63" diameter, 1.5mm / 0.059" round crest, flat board & E flute creasing wheel.
- G - Perforated tool:** Serrated cut wheel, Ø 32mm / 1.26", 3-1mm / 0.118-0.039" step.
- H - Perforating tool:** Serrated cut wheel, Ø 32mm / 1.26", 2-1mm / 0.078-0.039" step.
- I - Blade tool:** Metal wheel, 32mm / 1.26" diameter, for scoring polypropylene 250 ÷ 500gr.



3.7 TECHNICAL DATA

MODEL	Omnia V0708	Omnia V0710
Max cutting area	800x750mm (31.5" x 29.52")	1050x750 (41.34" x 29.52")
Cutting Capacity (Depending on type of head used and the material)	5 mm (0.19") 12mm (0.47") - with Oscillating Tool	
Max Speed	80 m/min	
Max Acceleration	4 m/s ²	
Air Requirements	7 bar – 101.5 PSI	
Rated power supply	400V – 50Hz, 4.9KVA, 3P+PE 400V – 60Hz, 5.2KVA, 3P+PE	400V – 50Hz, 5.6KVA, 3P+PE 400V – 60Hz, 6.1KVA, 3P+PE
Machine weight	630Kg (1382lbs)	704kg (1552 lbs)
Loader weight	260kg (573lbs)	
Sound emission	82dB	86dB
Connectivity	Ethernet; USB	
DATA Buffer	External PC	
File Formats	.SVG, .PLT, .DXF; .CF2; .PDF, .HPGL, .XML	
Tool Change	Manual	
No. Tools Holder	2 Slots	
Materials Holding System	Air Suction	
N° Vacuum Pumps	1	
Standard configuration	Cutting machine, loader, unloader, one cutting tool.	

3.8 PROPER USE OF THE MACHINE

The machine, depending on the tools is equipped with, can be used in the offset/digital printing sectors, or in the display and packaging market, to cut different kind of materials, see table 1, with a max thickness of 5mm (0.19") or 12mm (0.47") with oscillating knife.

Materials that can be processed with cutting tools

Paper and cardboard	Paper, folding cardboard, corrugated cardboard, honeycomb cardboard
Plastics	Forex, low density PVC, foams, rubber, polypropylene
Adhesives	Vinyl adhesive and plastic stickers,
Others	Magnetic sheets. Fabrics, leather without using the feeder

Table 1

Processing of materials other than those indicated in the previous table, must be authorized by the manufacturer after examining their technical data sheet.



CAUTION! To avoid damaging the cutting head, and the finished product, do not use material thicker than the tool can process .



DANGER! The machine is not suitable for use in a combustible atmosphere.

The machine is designed to be used in laboratories.



During the installation, the figures who will work with the machine and in particular the **User** and the **Maintenance Technician**, will be identified and trained.

	Tasks	Characteristics
Installer	The installer manages the machine positioning, checks the electrical connections, and starts the machine.	The Valiani technician, or whoever is appointed and trained.
User	User manages machine operations and eventually it also provides for cleaning.	Figure chosen by the "customer" with the scope of identifying the person/s who will be responsible of using the machine. This figure will be properly trained by the Valiani technician.
Maintenance Technician	The maintenance technician manages machine maintenance and repairs; therefore, it can also perform extraordinary activities with respect to those performed by the installer.	Figure chosen by the "customer" with specific technical knowledge able to be trained by the Valiani technician.

3.9 IMPROPER USE OF THE MACHINE

Omnia is not suitable for operation in potentially explosive atmospheres (ATEX)

Omnia cannot be used for processing materials other than those indicated in paragraph 3.9. In particular, materials such as:

- Glass fiber
- Carbon fiber
- Particularly flammable materials.

3.10 BEFORE USE

Before start using the machine, make sure is completely unlocked from any transportation security device, mounted on its feet, levelled and properly assembled and connected to a power source.



4 CONTROLS DESCRIPTIONS AND PREPARATION FOR USE

All commands relating to the machine's work cycle come from the computer. However, there are some commands that must be given directly from the machine and these are:

- Emergency buttons.
- Power on switch
- Starting the vacuum pump and selection of the suction zones.
- Loading of materials to be processed.
- Material Pick-up Roller

4.1 EMERGENCY BUTTONS

The EMERGENCY buttons must be used to immediately stop the machine in case of DANGER to the operator or risk for the machine itself. Each button has a mechanical stop to prevent the operator from accidentally pressing it again. To reactivate normal operations, turn the EMERGENCY button a quarter of a turn clockwise to release the mechanical stop. The machine is equipped with three emergency buttons (one on the loader and one on each of the two sides of the machine), pressing any of these buttons causes any movement of both the machine and the loader to stop.

To reactivate the machine, all three buttons must be active. You will also need to press the power button again.

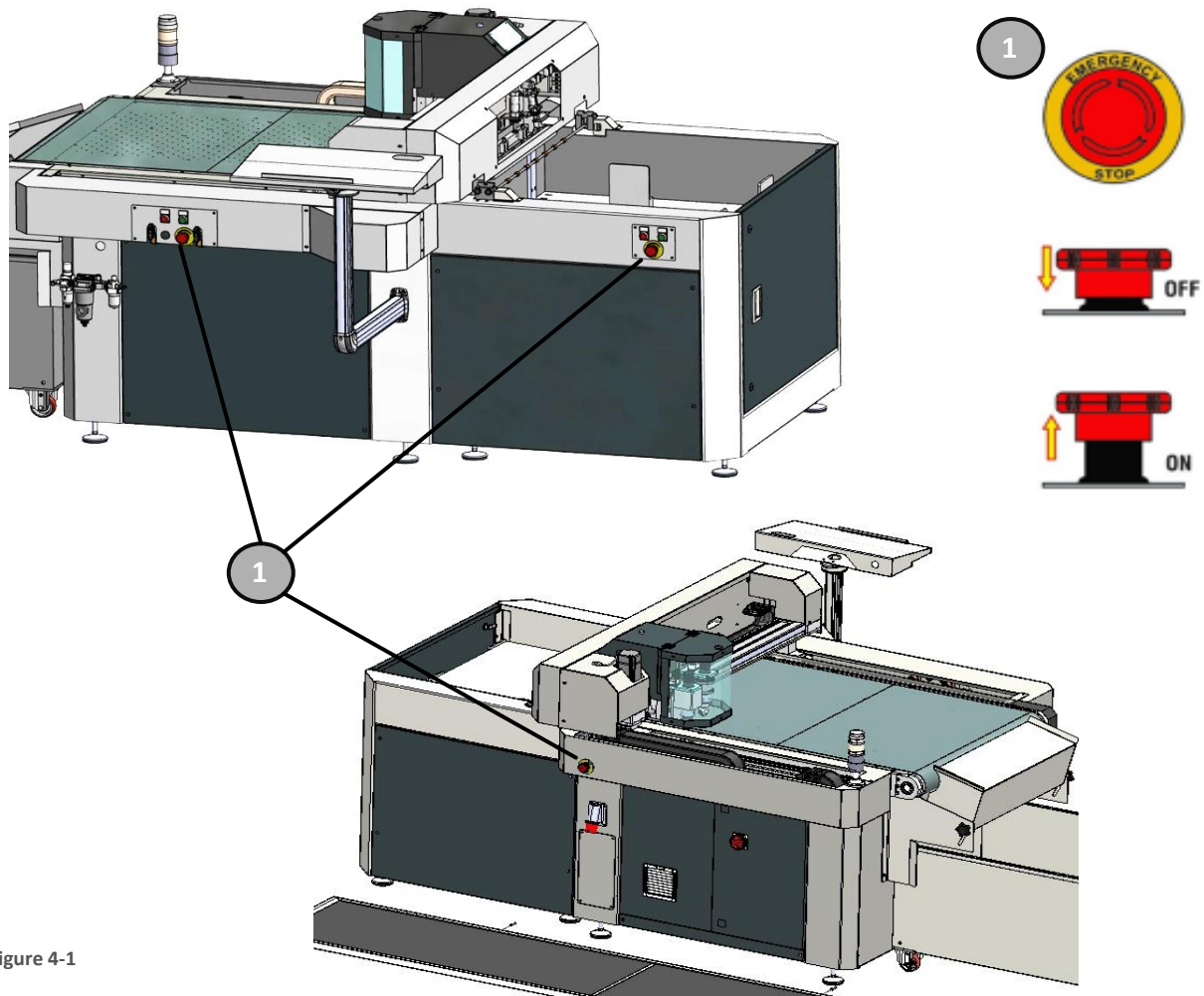

Figure 4-1



4.2 POWER ON SWITCH

Press button A Figure 6-2 to switch on power, the machine is then ready to execute commands.

4.3 STARTING THE VACUUM PUMP AND SELECTING THE SUCTION ZONES

Suction to the work surface is divided into three areas, two of which can be enabled or disabled depending on the "size of the material" to be processed.

Turning the pump switch (1) Figure 4-2 clockwise will start the vacuum pump. Turning the switch counterclockwise stops the pump motor.

The suction of zone 1 Figure 4-3 is always open and will be activated by the software when necessary for processing.

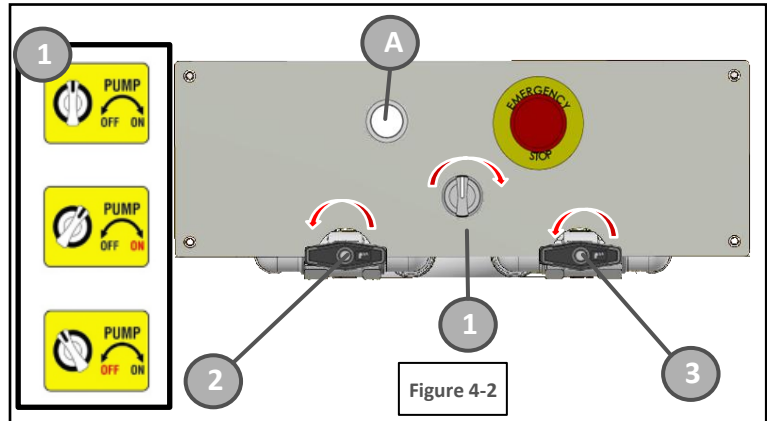

The two valves (2,3) Figure 4-2, if open, will ensure that when the software activates suction it is extended to the corresponding sectors of the table Figure 4-3.

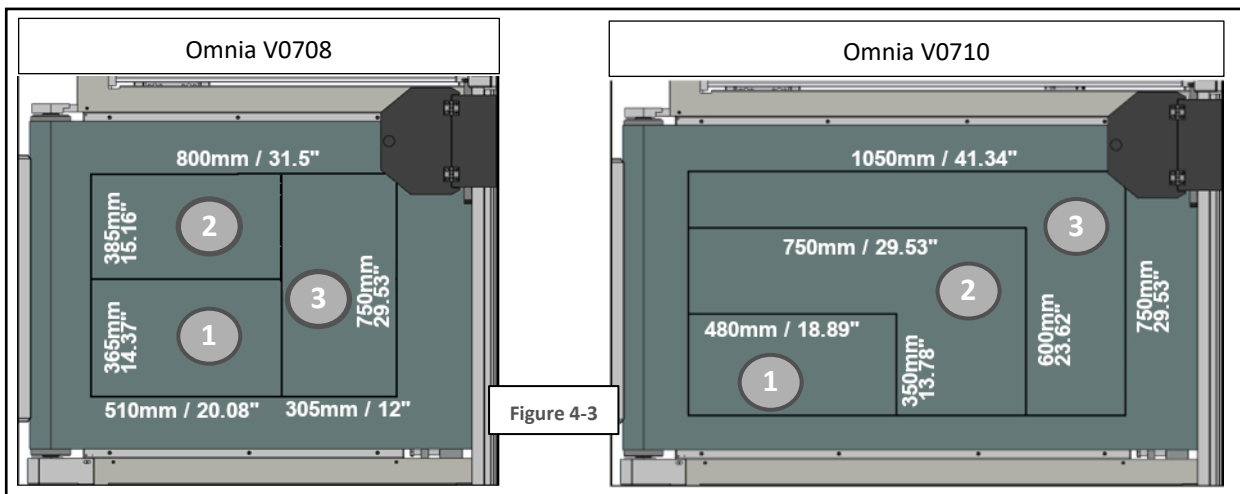

Note: Switching on the pump does not directly produce suction on the surface as this is controlled via software.

Note: If the software is set to energy saving mode, the pump will be automatically switched off after a certain period of inactivity.

4.4 LOADER CONTROLS

On the side of the loader are two selectors and an emergency button.

When the left selector is positioned on the MAN function, the automatic return selector is enabled which allows the loading surface of the materials to be processed to be raised (UP) or lowered (Down).

When the manual material loading operations are completed, the left selector must be returned to the AUTO position in order to allow or resume the automatic processing cycles.

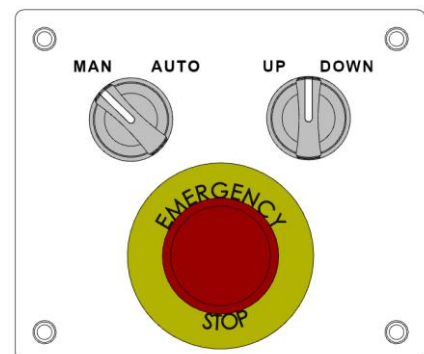

Figure 4-4



4.5 MATERIAL PICK-UP ROLLER

The presser located on the top of the loader allows slightly deformed materials to be crushed so as not to cause false readings to the “sheet ready” photocell.

Based on the thickness and stiffness of the materials, it can be adjusted in order to have a fair compromise between the pressure on the material and the intervention height.

When using materials with a thickness greater than 3mm (0.012 "), loosen the knobs on the sides of the pressure bar and lift the presser to the desired height (same height on both sides), then re-tighten the knobs.

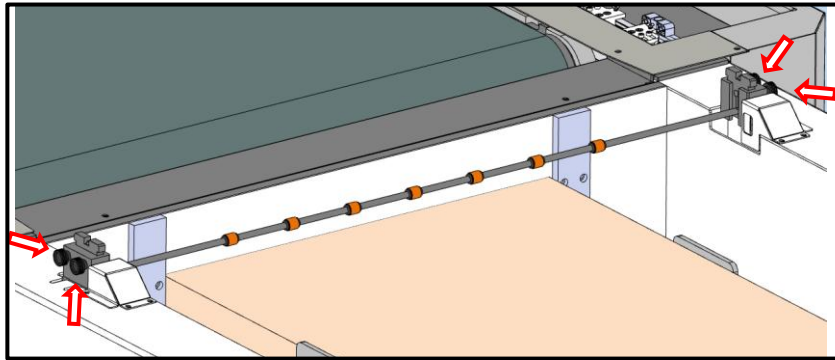

Figure 4-5

4.6 DESCRIPTION OF SIGNAL LIGHTS

The machine is equipped with a light tower that provides the operators with some useful information as described below:

Colour	Description
Constant red:	Warning: Emergency buttons pressed; pressure on safety mats; compressed air pressure is low; disconnected auxiliary or thermal switches on the electrical panel.
Flashing red:	Alarms reset, reactivate the machine by pressing the ON button (Figure 6-2 A)
Rotating orange:	Waiting for PC connection
Constant green:	Work cycle in progress
Flashing green:	Cycle in pause programmed for operator intervention
Flashing orange:	<ul style="list-style-type: none"> • Cycle in unscheduled pause, operator intervention required • Sheet loss during loading cycle
Constant orange:	Manual loading and loader cycle start
Constant blue:	<ul style="list-style-type: none"> • Loading cycle start, missing sheets • Loading cycle start, too many sheets on the loader
Flashing blue:	Reserve sheets loader

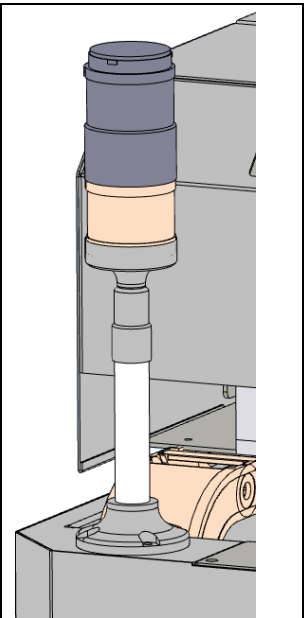

Figure 4-6

Another element that signals the adequacy of the air pressure is the oiler display (**Error! Reference source not found.**) which, in addition to displaying the instantaneous pressure, changes the color of the digits from green to red if the pressure falls below the minimum required threshold.



OMNIA

The light tower is equipped with a telescopic arm that allows it to be lengthened:

To change the height of the turret, loosen the ring nut while holding the upper part of the turret.

Pull the upper part up to the desired height, then re-lock by tightening the ring nut.

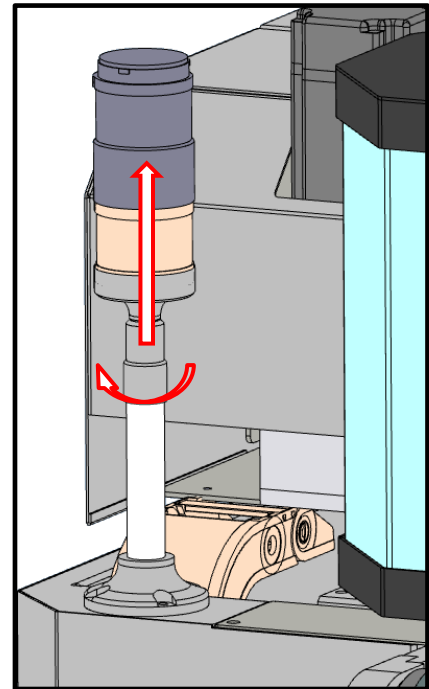

Figure 4-7

4.7 PREPARING FOR USE

This paragraph is intended to list the important task to use the machine:

- Power the machine on by turning the selector on the electrical panel of the machine clockwise - **Error! Reference source not found.**
- Insert the power by pressing the Machine Power key (A), Figure 4-2.

Note: If the button does not light up, check if any of the emergency buttons - Figure 6-1 - were pressed down, if so disarm them (see par. 6.1) and repeat the pressure of the Machine Power key.

- Turn on the PC on and start the V-Studio program



CAUTION: To enable the connection between the PC and the machine, the machine must be switched on and connected to the PC before opening V-Studio

- From V-Studio control panel click on SmartCut, once the connection has been established, make the machine ready using the ROXY button.
- Lower the loading feeder and place the materials as described in paragraph 6.7.
- Start the suction pump using the selector (1) and according to the size of the media open or close suction zone (3) simply turning taps CW or CCW as images explain (2) Figure 6 2.
- On pc Open ImageCut and add the file to be executed and the quantities required, Start the automatic cycle and follow the instructions provided on the screen.
- Make the necessary adjustments Paragr. 7.
- To interrupt a process, pause and restart it, simply press the appropriate keys on the PC (see software manual).
- In case of danger, it will be sufficient to press the emergency button to instantly block and cut power off to the machine. Figure 6-1.

To reset the machine:

- Disarm the emergency button (see paragraph 6.1)
- Press the Machine Power button (A), Figure 6 2



- Restore the program on the PC (see software manual).

4.7.1 POSITIONING THE MATERIAL ON THE LOADER TABLE

Two loading/processing modes are available; the first foresee to have all materials stacked on top of each other, the second to have the same material/job loaded on two stacks side by side.

The second mode allows processing two sheets at the time, reducing loading times by half.



Note. The dual Sheet mode is only available for sheets with a maximum width of 340 mm (13.38") and a minimum width of 200mm (7.87").

4.7.1.1 STANDARD POSITIONING THE MATERIAL ON THE LOADER TABLE

To load the materials, place the loader selector in manual mode (MAN), (Figure 4-4) then keep the Up / Down selector in the Down position to lower the loading surface.

Position the materials to be processed on the loading surface so that they are pushed against the stop on the front and against the stop on the left side for the 0 position.

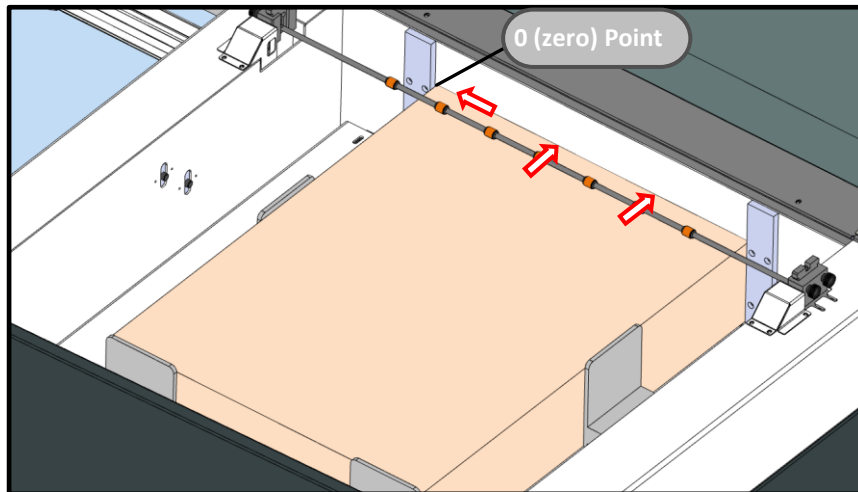

Figure 4-8

Then place the movable stops on the sides of the materials to keep them in the correct position.

Be careful not to position the supports beyond the line drawn on the surface (A), as they would interfere with the reading of the photocells.



NOTE! To ensure the correct function of the loading phase, we recommend always using materials of the same type and size within a work cycle.

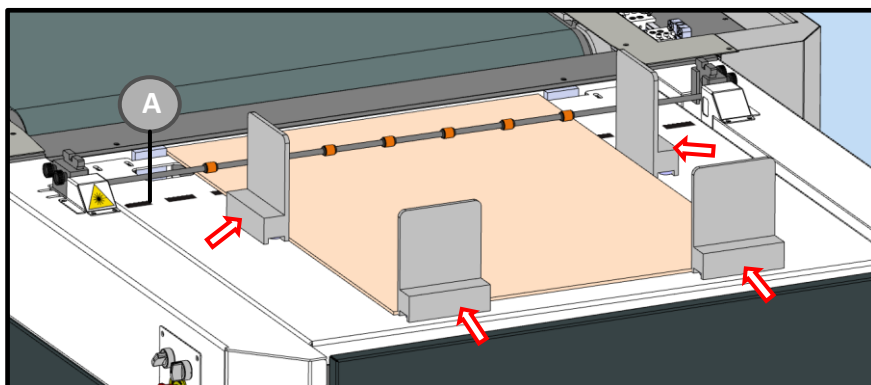

Figure 4-9



After placing the materials and supports on the loading surface, return the selector to AUTO mode.

4.7.1.2 MATERIAL POSITIONING FOR DUAL SHEETS MODE



Note: The side of the sheets facing the front of the feeder can be min 200mm (7.87 ") wide and max 340mm (13.38") wide.



Note: in order to have the machine working at its best we recommend to have the two stacks of the same height (materila quantity).

To run the dual sheets mode it is important to follow the below instructions to correctly load the materials. First of all set Manual Mode (MAN) on the feeder (Figure 4-4) , than keep pressing the UP/DOWN selector on DOWN side lower the loading work surface.

While positioning the material pay attention to:

- the side with a width between 200 and 340 mm, touches the front of the feeder.
- the left side touches the reference plate (Point 0 nr. 1).

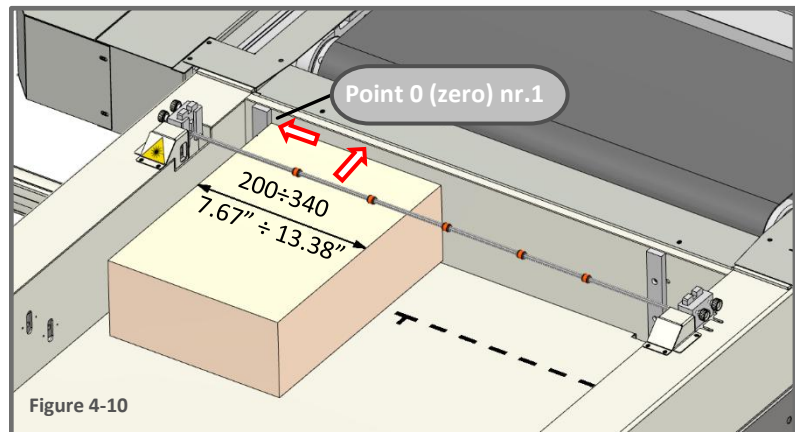

Figure 4-10

Then place the movable stops on the left side and on the back of the material to keep the material aligned eachother.

Warning: Make sure to do not position the movable stops beyond the line drawn on the surface (A), as they could interfere with the reading of the photocells.

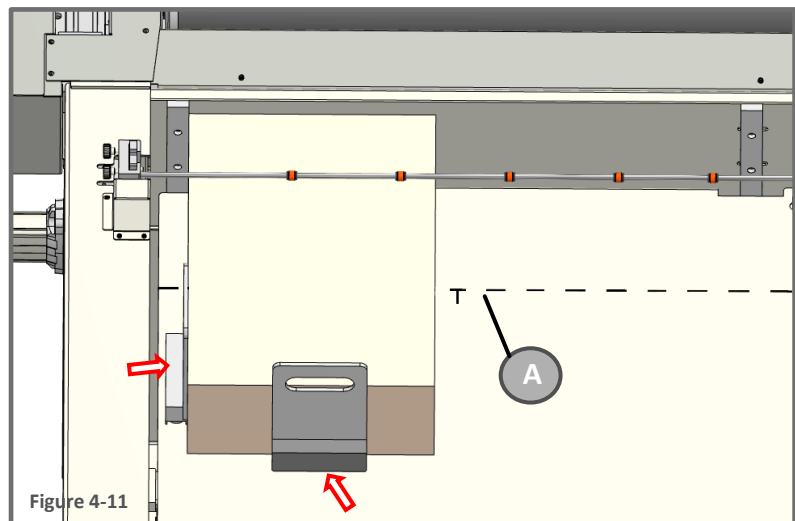

Figure 4-11



OMNIA

Place a movable stop facing the right side in correspondence with the mark (B) on the magazine.

Warning: As we previously did, make sure to do not position the movable stops beyond the line drawn on the surface (A), as they could interfere with the reading of the photocells.

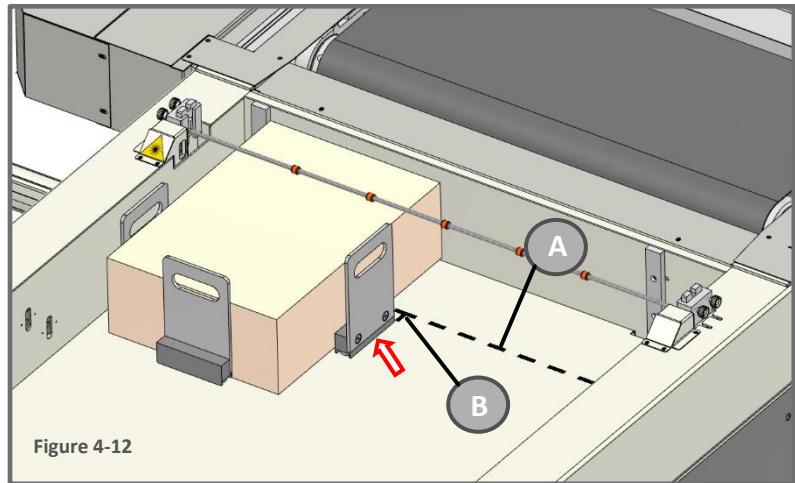

While positioning the material pay attention to:

- the side with a width between 200 and 340 mm, touches the front of the feeder.
- the left side touches the reference plate (Point 0 nr. 2).

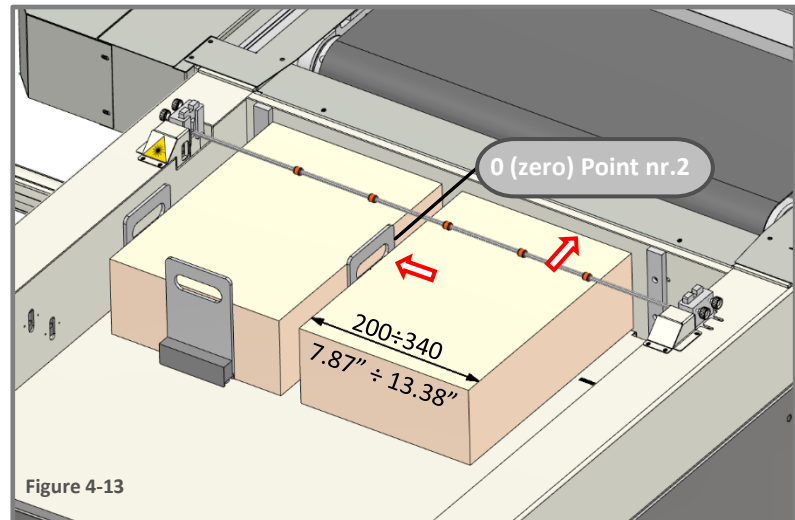

Figure 4-13

Place a movable stop on the right and back side to keep material aligned.

Warning: As we previously did, make sure to do not position the movable stops beyond the line drawn on the surface (B), as they could interfere with the reading of the photocells.

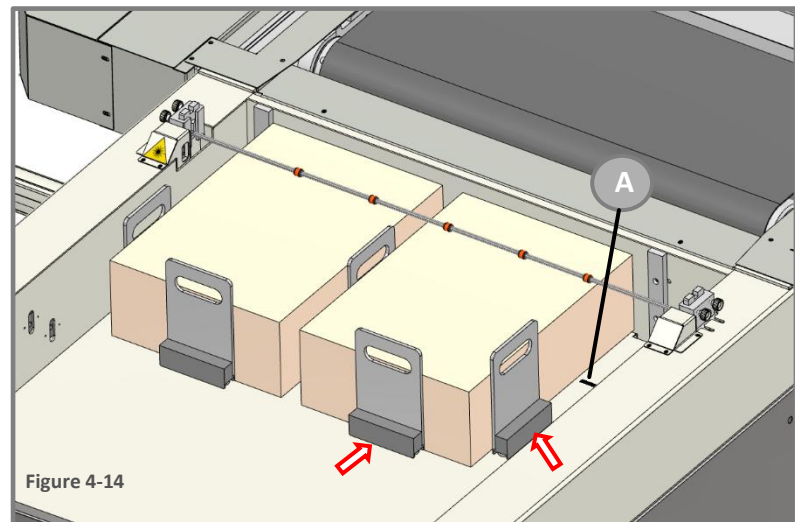

Figure 4-14

After placing the materials and supports on the loading surface, return the selector to AUTO mode.

4.7.2 SWITCHING ON THE VACUUM PUMP

Turn on the vacuum pump and set the tap according to the material size (Figure 4-2)



4.7.3 TANGENTIAL TOOL PREPARATION



DANGER: Use protective gloves is strongly recommended, be very careful as the pressure of the moving part (2) could cause the blade exit.

To mount or replace the blade holder, proceed as follows:

Note: Depending on the blades being used for the desired processes, the relative dedicated blade holder must be mounted (blade holder for L100 / L1W blades or blade holder for flat blades T16 / 17).

- a) Loosen the locking set screws (1) and remove the movable blade guard (2) Figure 4-15.

Attention: If a blade holder equipped with a blade is already present on the tangential tool, first proceed with the disassembly of the latter in order to avoid possible accidental injuries (carry out point (e) and then resume the procedure from point b).

- b) Loosen the set screw (8) and extract the blade holder (9).
 c) Insert the desired blade holder with the reference pin (10) oriented as shown in the figure and make sure that it is entered up to the stop.
 d) Tighten the set screw (8).

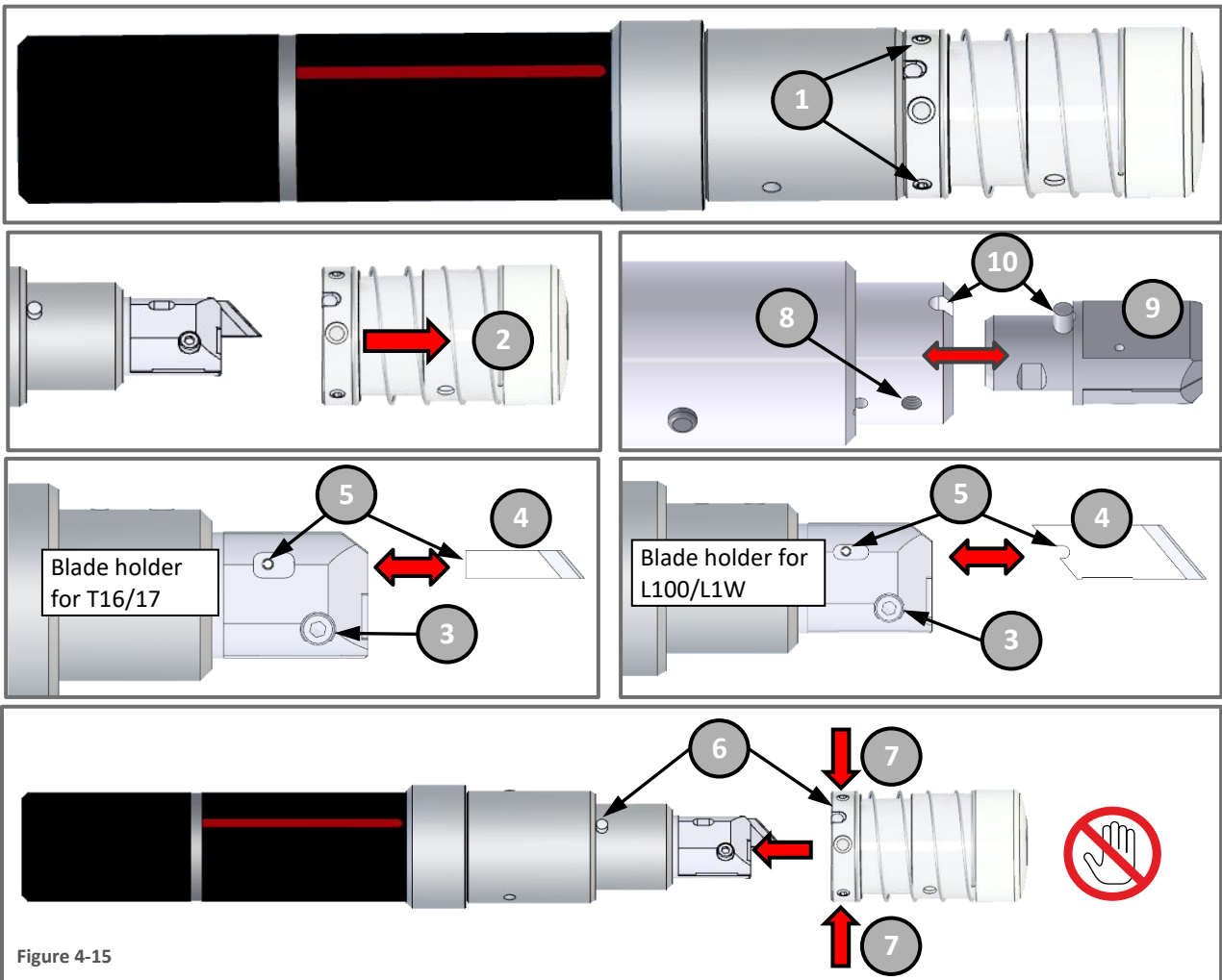

Figure 4-15

- e) Loosen the blade cartridge screw (3) and remove the used blade (4) (if present).
 f) insert a new blade (4) until the notch of blade reaches the pin (5), then tighten the screw (3).
 g) Position the blade guard so that the reference pin matches its housing (6), then grab it from the sides (7) and push it towards the tool.

Attention: while inserting the blade protection, pay attention the palm of your hand is not positioned in front of the tool as indicated by the prohibition symbol.

- h) Tighten the locking set screws (1).

To replace a blade, carry out the procedure described above, skipping points b) c) d).



4.7.4 OSCILLATING CUTTING TOOL PREPERATION (OPTIONAL)



DANGER: Use protective gloves is strongly recommended, be very careful as the pressure of the moving part (2) could cause the blade exit.

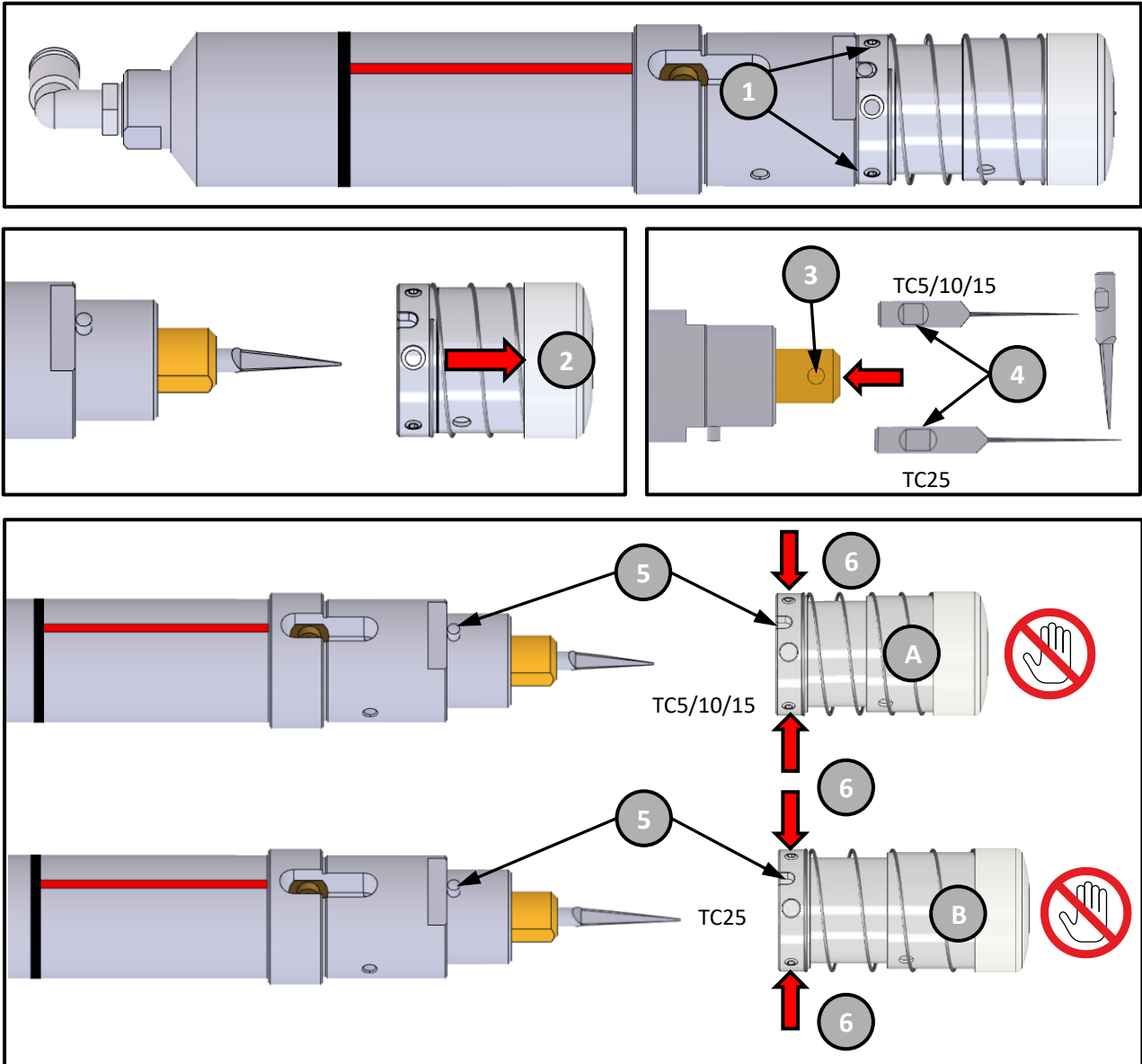

Figure 4-16

- Loosen the locking set screws (1) and remove the movable blade guard (2).
- Loosen the blade holder screw (3) and insert a new "TC" Type blade, paying attention that the blade notch (4) matches the locking screw and then push it inside until to the stop and tighten the screw (3).
- Position the blade guard (A) or (B), depending on whether we have chosen a TC5/10/15 or TC25 type, paying attention that the reference pin fits into its housing (5), then grab it from the sides (6) and push it towards the tool.

Attention: while inserting the blade protection, pay attention the palm of your hand is not positioned in front of the tool as indicated by the prohibition symbol.

- Tighten the locking set screws (1).



4.7.5 X TYPE OSCILLATING TOOL PREPARATION (OPTIONAL)



DANGER: Use protective gloves is strongly recommended, be very careful as the pressure of the moving part (2) could cause the blade exit.

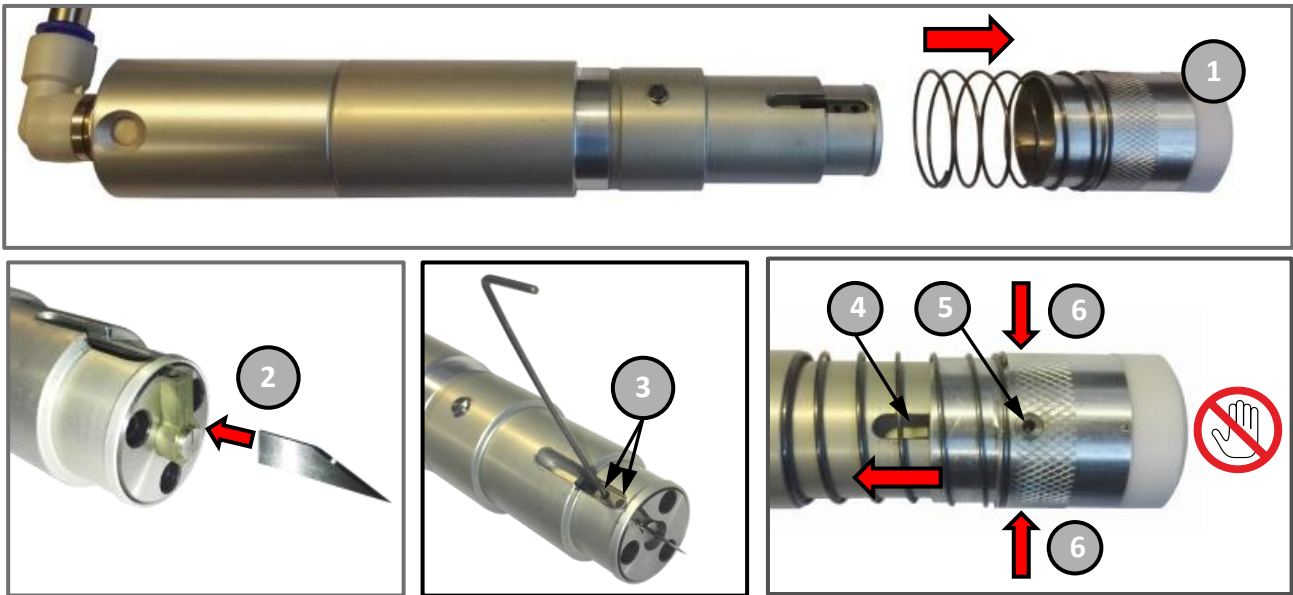

Figure 4-17

Remove the blade guard (1) by pulling it outwards.

- Insert a flat blade into its housing with the tip facing the center of the tool (2).
- Tighten the two blade locking set screws (3) with a 1.5mm Allen key
- Position the blade guard so that the reference pin (4) matches the sliding slot (5), then grab it from the sides (6) and push it towards the tool.

Attention: while inserting the blade protection, pay attention the palm of your hand is not positioned in front of the tool as indicated by the prohibition symbol.

4.7.6 PREPARING THE KISS-CUT TOOL (OPTIONAL)



WARNING : Use protective gloves to prevent cuts.

Unscrew the blade shaft (counter-clockwise), then pull it out.

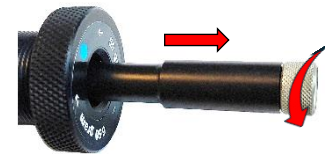

Insert the blade extractor onto the blade, then push on both side and pull the blade out of the seat.



Place a new blade paying attention to the correct side.

Insert the blade shaft back into the tool and screw it back in until the desired cutting blade depth is reached.



4.7.7 PREPARING THE T-MARK TOOL

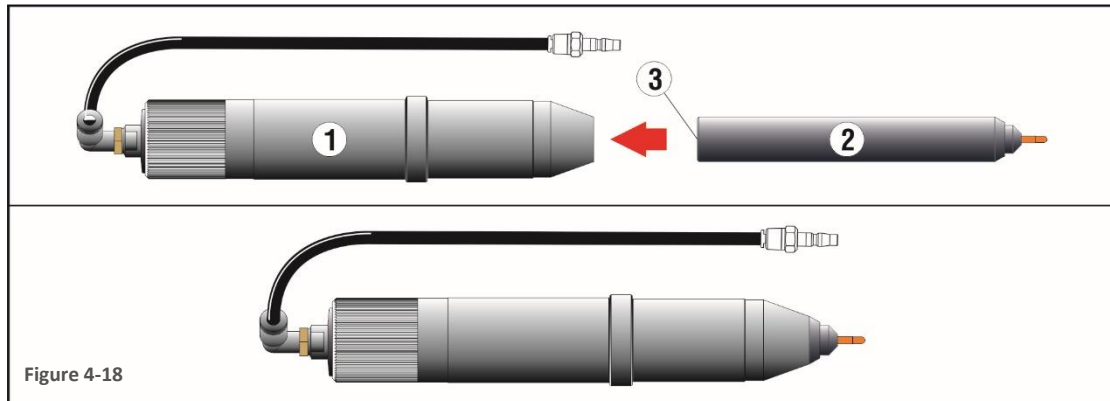

Insert the pen cartridge (2) into the penholder (1), as shown in the diagram above, until the magnet (3) holds the cartridge.

4.7.8 PREPARING THE CREASING TOOL

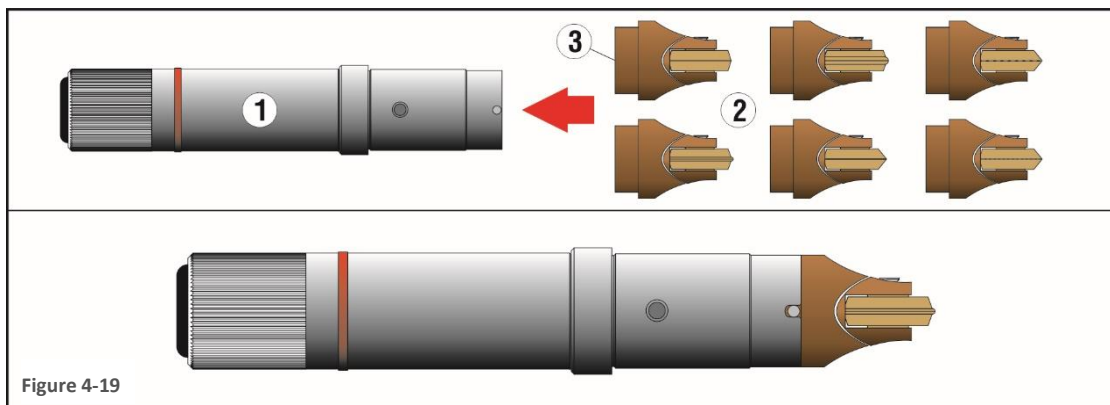

Insert one of the nine creasing wheels available (2) as shown in the diagram above until the magnet (3) at the base of the tool holds to the creaser.



4.7.9 FITTING A CUTTING BLADE VERSATOOL (OPTIONAL)



Warning! Handle the blade carefully, protect it, if necessary, to avoid cutting. During reassembly use a rubber object to keep it in its housing during tightening of the locking screw.

- Disassemble the head (see chapter 4.7.14).
- Remove the blade holder (1) from the cutting head by loosening the set screw (2) with a 3 mm Allen wrench.

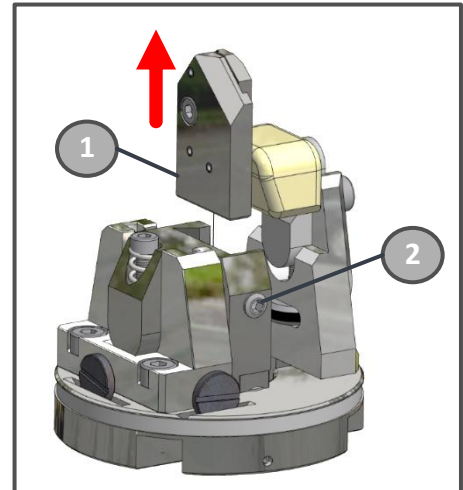

Figure 4-20

- Loosen the blade holder screw (3) with a 2.5 mm Allen wrench and insert the blade (4) until it reaches the pin (5), then tighten the screw (9).

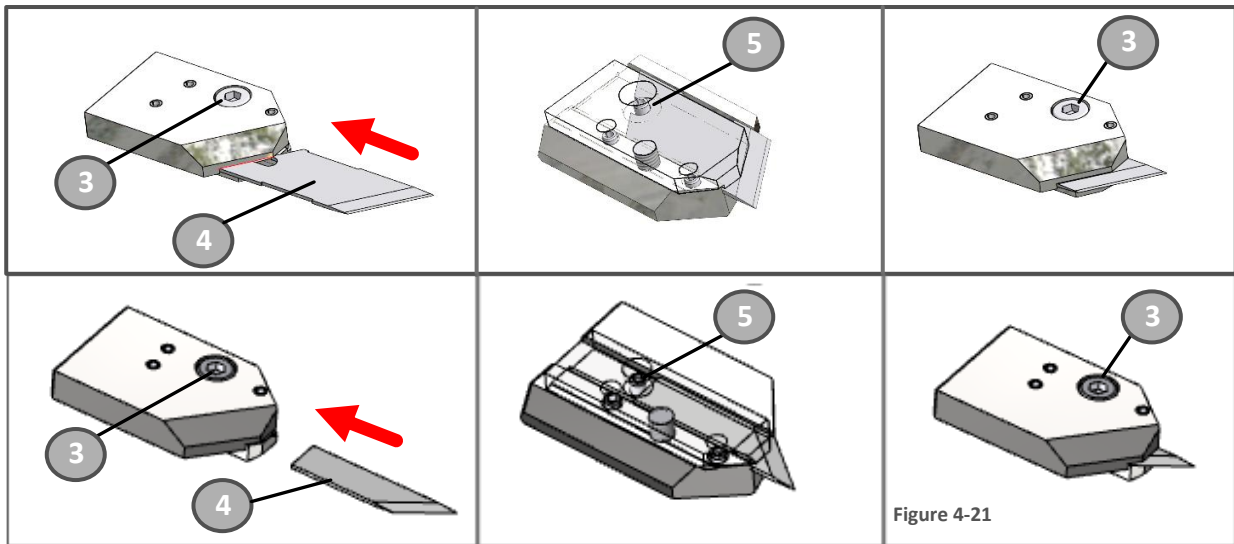

Figure 4-21

- Insert the blade holder (1) into the cutting head and tighten the set screw (2).

- Reassemble the head (see chapter 4.7.13).

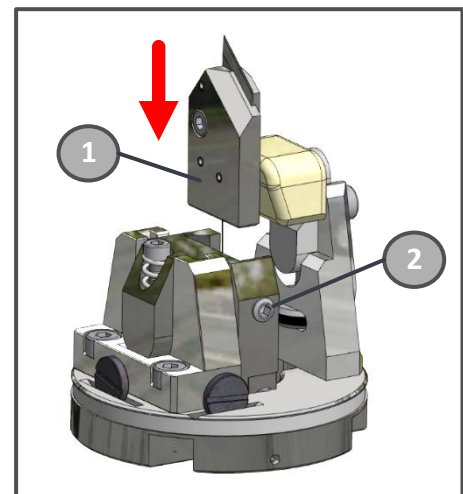

Figure 4-22

4.7.10 REPLACING THE FOOT/ROLLER ON WHITE HEAD - VERSA TOOL (OPTIONAL)





Warning! Handle the blade carefully, protect it, if necessary, to avoid cutting. During reassembly use a rubber object to keep it in its housing during tightening of the locking screw.

To replace the roller with the presser foot, and vice versa, proceed as follows:

- Disassemble the head ([see chapter 4.7.14](#)).
- Remove the blade holder ([see chapter 4.7.9](#)).
- Unscrew the screw (6) to remove the roller and the support (7).
- Screw the foot (8) with the screw (6).

Follow the same procedure to replace the foot with the roller.

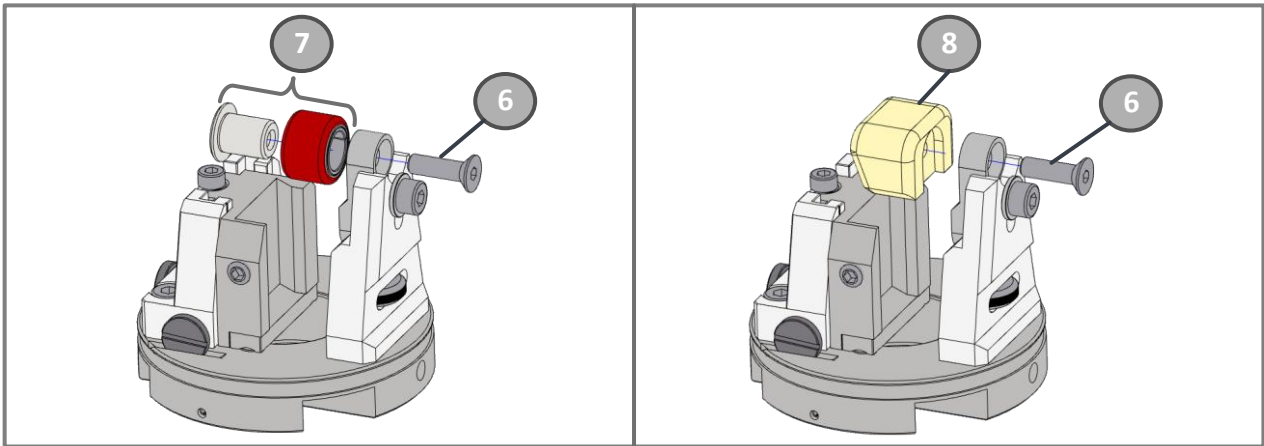

Figure 4-23

- Reposition the blade holder ([see chapter 4.7.9](#)).
- Reassemble the head ([see chapter 4.7.13](#)).



4.7.11 HEAD ACCESS

To access the heads to change the cutting tools or to adjust the working height, simply pull the protection upwards until it flips over the sheet metal casing. A magnet will secure it in the open position.

Pull it down in the opposite direction to close it again. When in position other magnets will ensure that it is kept in position.

Figure 4-24

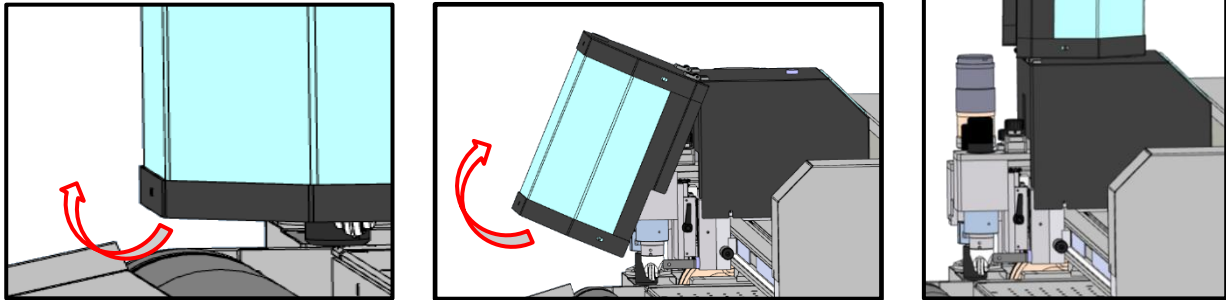

4.7.12 MOUNTING TOOL

The cutting tools (A-B) have to be fitted to head holder 1 while the creasing (C), penholder (D) and VersaTool (E) have to be fitted to head holder 2. It is not possible to invert the tools.

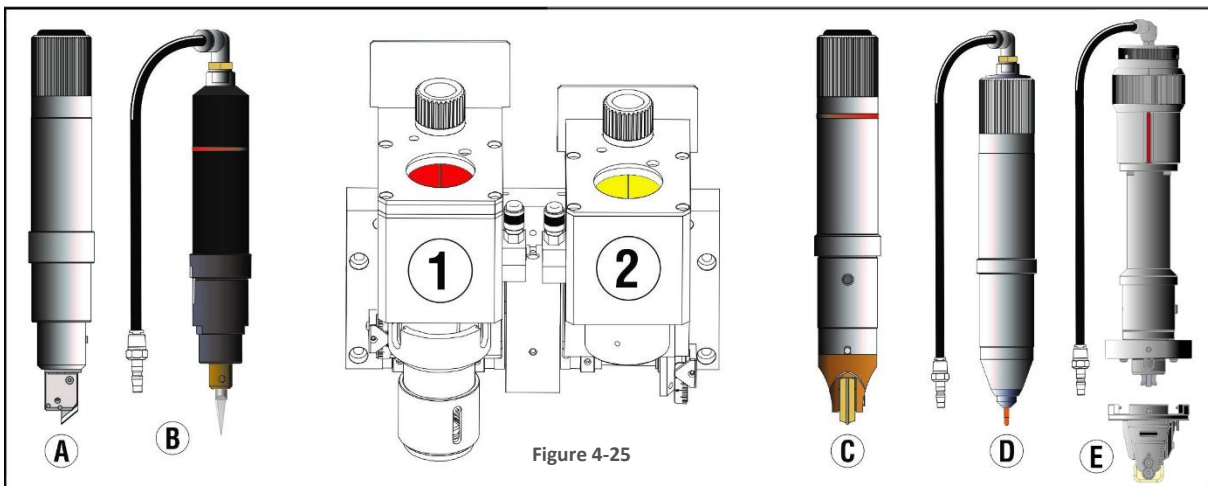

Figure 4-25

Use the screwdriver (N) supplied with the accessories to:

- loosen socket head screw (L) to allow insertion of the tangential or oscillating tool
- loosen socket head screw (M) to allow insertion of the creasing, T-Mark tool or VersaTool.

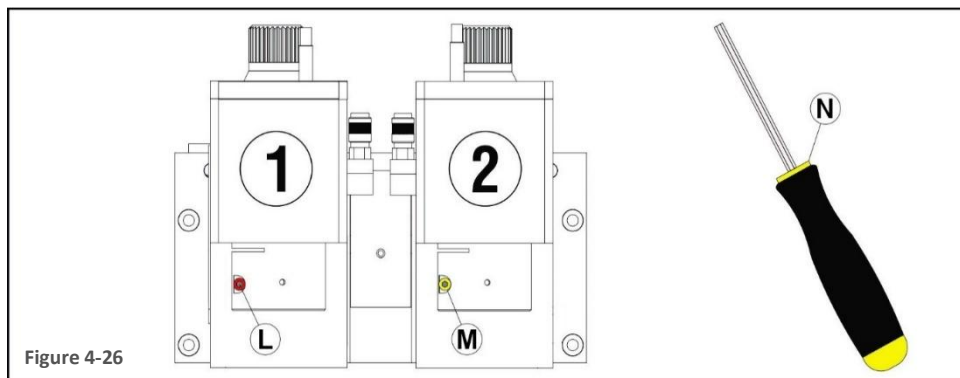

Figure 4-26

- **Attention:** to use the Versatool it is necessary to first loosen the screw (X) and extract the magnet support (Y).



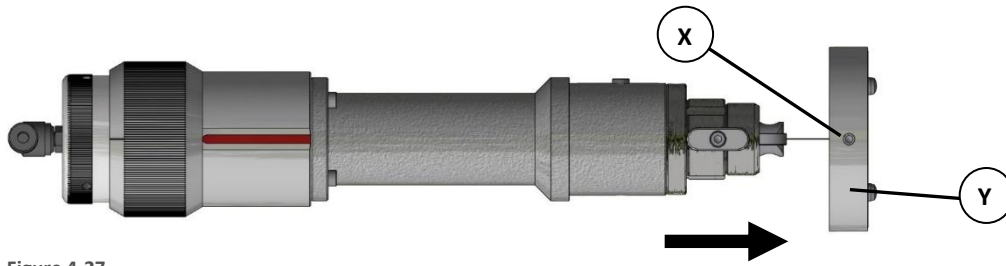

Figure 4-27

Once the screws are loosened insert tools in the appropriate slots (1 or 2) making sure it has reached the correct position, as shown in the diagram below.



Caution: The pin "Y1" must coincide with the slot "Y2".

Once inserted, tighten the previously mentioned socket head screws (L and M) and insert the male air connectors (F), if present, into the appropriate female connectors on their head holder units.

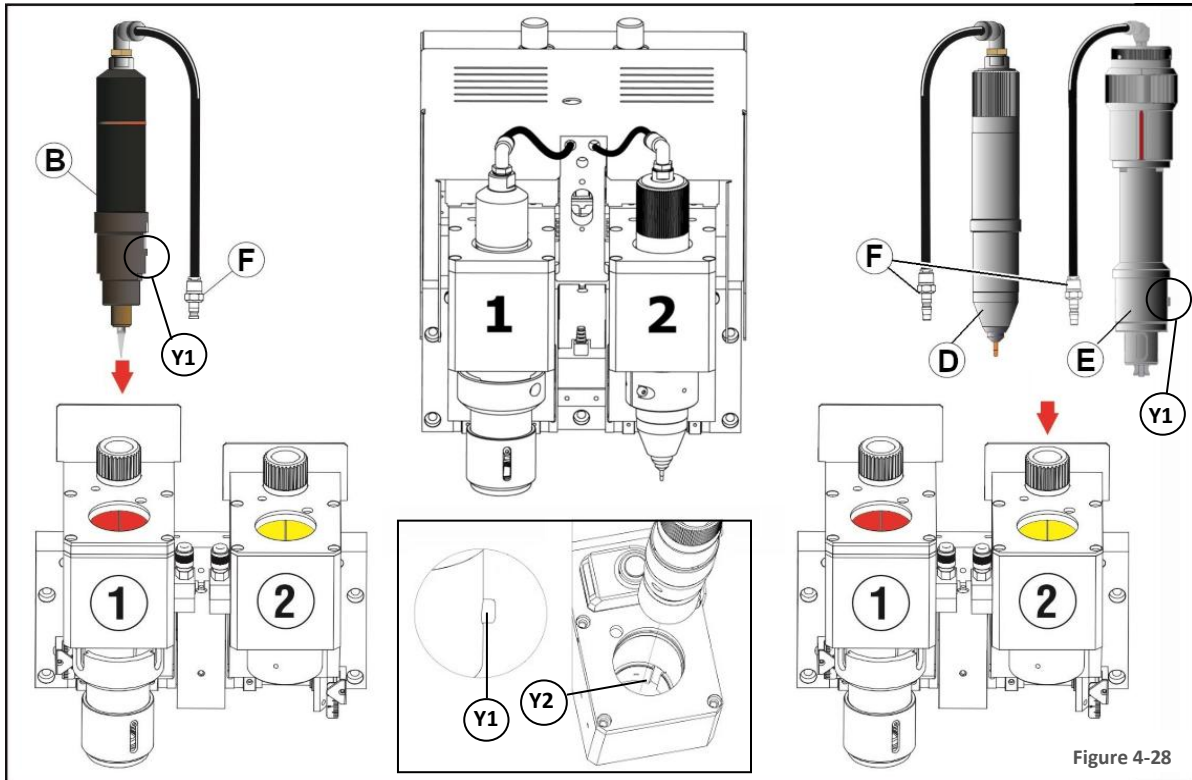

Attention: The VersaTool assembly must be completed by reinserting the magnet support (Y) and tightening the screw (X).

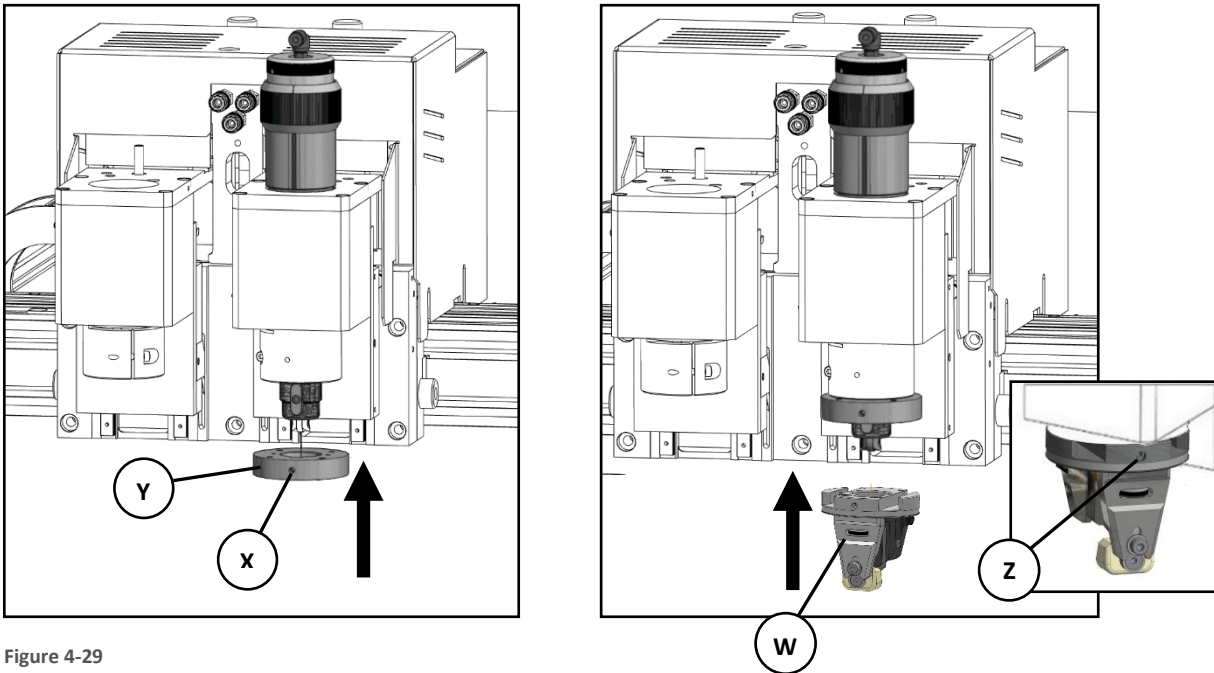

Figure 4-29

4.7.13 ASSEMBLING THE VERSATOOL HEAD

When mounting a head (W) on the VersaTool, insert it under magnet holder and when it adheres to the flange, tighten the screw (Z) (Figure 4-29).

4.7.14 DISASSEMBLING THE VERSATOOL HEAD

If it is necessary to replace the head with another one, proceed as follows:

- Loosen the screw (Z) (Figure 4-29).
- hold the release tool/fork (1) by its handle and insert it into the slot located in the top part of the head. Holding the tool with one hand support the release fork tool with the other, insert into the head slot (2) and give it a slight knock to free the head.
- This will detach the interchangeable head from the retaining magnets, and it will remain attached to the magnets of the release tool (3)
- Pull away the released tool.
- Fit the most suitable head for the cut (paragraphs [4.7.13](#)).

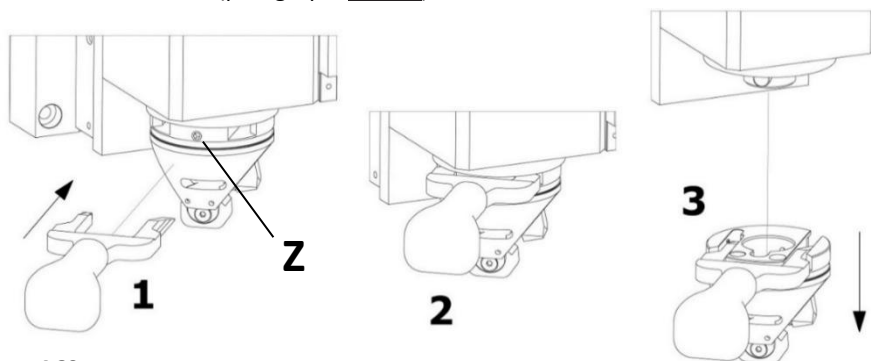

Figure 4-30



5 ADJUSTMENTS

To ensure a perfect result it may be necessary to perform some manual adjustments, such as:

5.1 ADJUSTING CUTTING AND CREASING DEPTH

To cut, it is essential that the cutting blade depth slightly exceeds the thickness of the material being cut. To obtain this condition it is necessary to carry out the following operations: Loosen the knob (1), turn the head register (2) anticlockwise (to increase), or clockwise (to decrease) the blade cutting depth. Then tighten knob (1).

To adjust the creasing pressure you should loosen the knob (3), turn the register (4) anticlockwise (to increase), or clockwise (to decrease) the creasing pressure. Then tighten knob (3)

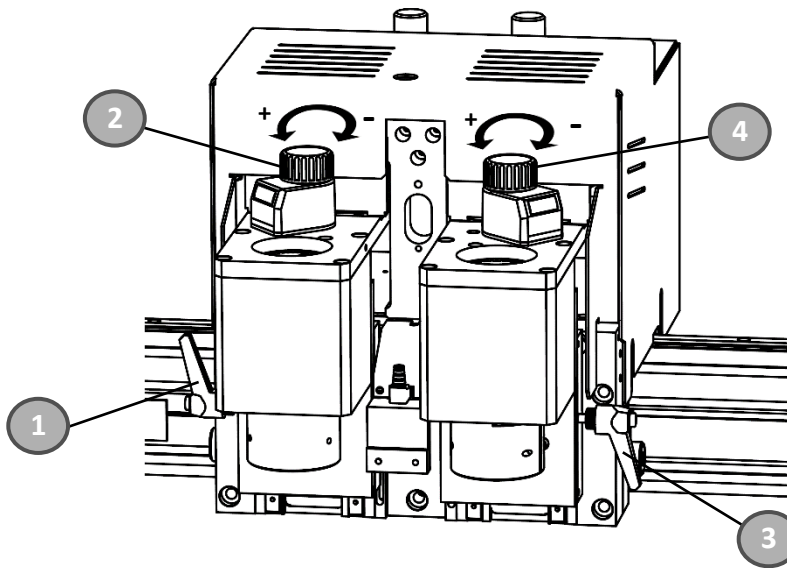

Figure 5-1

5.2 REGULATING THE VERSATOOL CUTTING DEPTH

To adjust the VersaTool cutting depth is sufficient turn the knob (1) anticlockwise (to increase), or clockwise (to decrease) the cutting depth.



NOTE! One unit on the counter corresponds to 0,1 mm (0,004").
Ten units correspond to 1 mm (0,040")

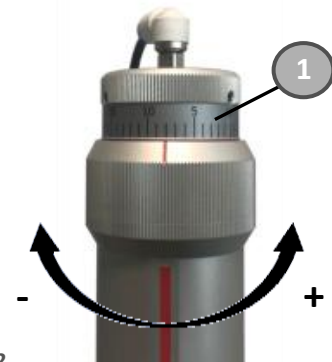

Figure 5-2



5.2 ADJUSTING THE CUTTING PRESSURE OF THE KISS-CUT TOOL

Once inserted the standard knife blade into the knife holder. Make sure the knife blade is firmly fixed in the holder. The knife is inserted correctly if it cannot be removed manually from the knife holder. The installation tool can be used to apply enough pressure on the knife to secure it.



Figure 5-3

Gently insert the knife holder into the tool shaft. Hold the nose piece in place with one hand and, with the other hand, turn the knife holder counterclockwise until the alignment pin fits into the small notch of the tool shaft. Now, turn the knife holder clockwise until its thread takes hold inside the tool shaft.

Choose the correct spring (3) based on the material thickness and consistency, so that the applied cutting pressure can be manually adjusted accurately for the specific material.



Figure 5-4

Hold the nose piece in place with one hand. Adjust the knife depth with the other hand by turning the knife holder clockwise until the knife tip is just visible from under the nose piece.

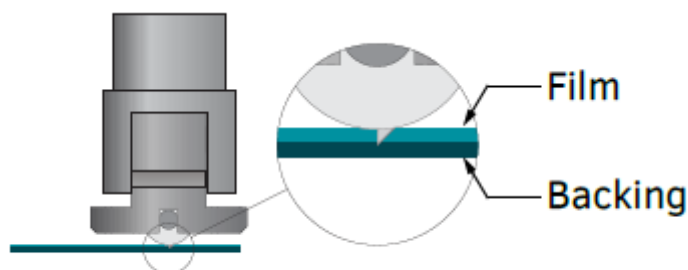

Figure 5-5



5.3 ADJUSTING THE DOWN PRESSURE OF THE CUTTING HEAD

To cut special hard materials, or to avoid the wheel on the cutting head leaves a mark on soft materials, it may be necessary to adjust the pressure of the air in the cylinder controlling the head down pressure. Adjustment can be made as follows:

Remove the protection glass by unscrewing the four locking screws (A). Pull knob (1) out (on) for a short distance to release the pressure regulator. Turn the knob (1) until it reaches the pressure necessary for the blade head to operate correctly. When the correct pressure is reached push the knob (1) home to lock in place (OFF), then reassemble the protection glass with the four screws removed previously.

To perform a Kiss cut with VersaTool, the switch (K) must activate by moving into KISS-CUT ON mode (K).

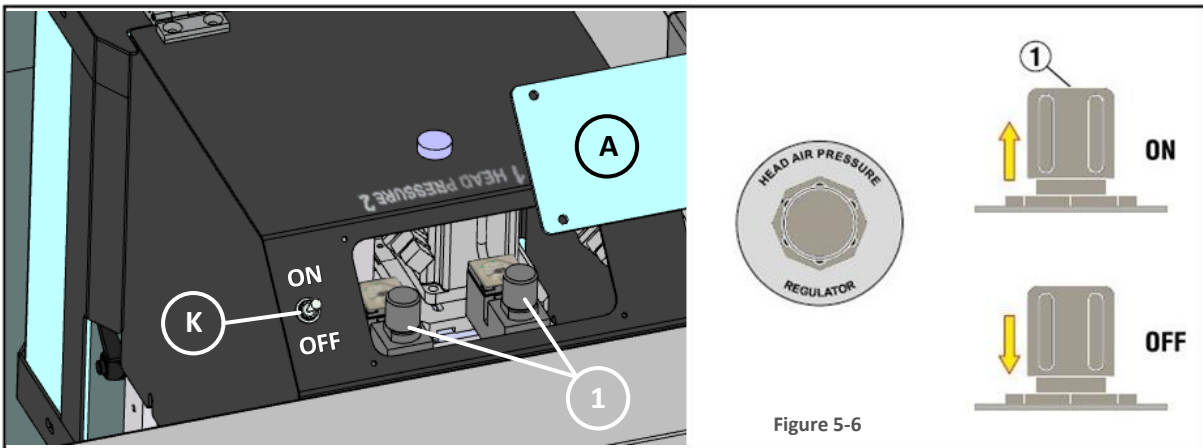

Figure 5-6



NOTE! We suggest that you adjust the pressure in a range between 0.3 and 0.5 bar depending on the thickness of the materials to be processed.



NOTE! When you finish a kiss-cut, turn the switch (K) to KISS-CUT OFF mode before performing any other processing to avoid damage to the work table

5.4 ADJUSTING THE UNLOADING CHUTE INCLINATION.

Based on the materials to be processed and their dimensions, it may be appropriate to adjust the inclination of the discharge chute.

To change the inclination, simply loosen the two knobs on the sides of the slide, adjust it to the desired height and re-tighten the knobs.

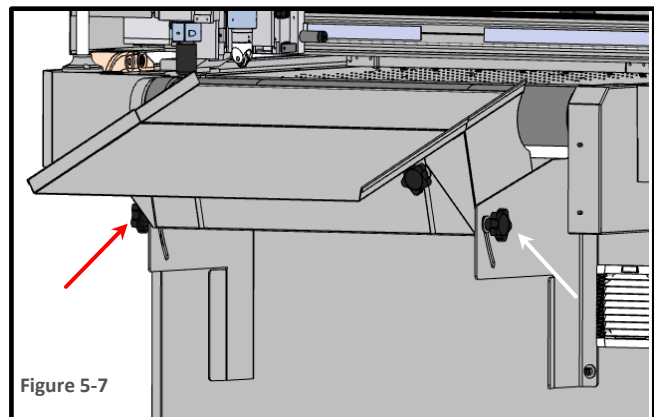

Figure 5-7



6 ROUTINE MAINTENANCE

Very little maintenance is required, and it is limited to the operations detailed in the following paragraphs.



CAUTION! Please disconnect the machine from the electrical mains supply, before carrying out any maintenance operations

6.1 CLEANING

One of the most important maintenance tasks is the frequent and complete cleaning of the following parts:

Worktable (daily)

- Clean the top of the work table everyday with compressed air or with a soft and dry brush.

Electrical panel fan and the base (every week)

- Switch off the machine.
- Remove the air filter cover using a screwdriver
- Blow the fan and the air filter with compressed air.
- Reinsert the filter inside the cover and fit it into the seat under the fan.

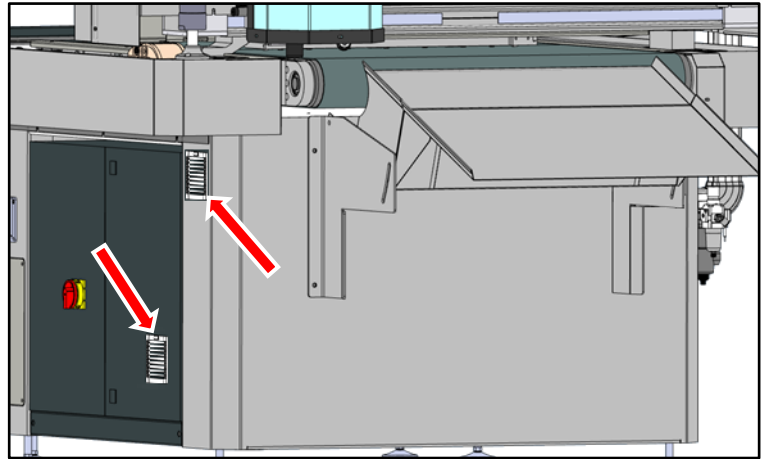

Figure 6-1

Cutting head (Everyday)

- Clean the cutting head using compressed air or with a soft dry cloth to remove dust and any debris left from production.
- Check for, and remove, any dirt on the blade protection holder.



DANGER! Before cleaning the cutting tools remove the blade to avoid any accidental injury.

Vacuum pump cleaning.

Before carrying out any operation, switch off the machine and disconnect it from the mains power supply. Follow the instructions provided with the pump documentation. To access the pump, remove the machine protection panel (**Error! Reference source not found.**).



Cutting blade running guide (every 1 - 2 months for all VersaTool cutting heads type)

Remove the blade as previously described. Lubricate the guide at points (1) and (2) with a small amount of spray grease taking particular care not to allow any grease to reach the rubber roller. Carefully wipe off all excess grease before re-inserting the cutting blade. It is absolutely essential that you do not allow any lubricant to come into contact with the rubber roller.

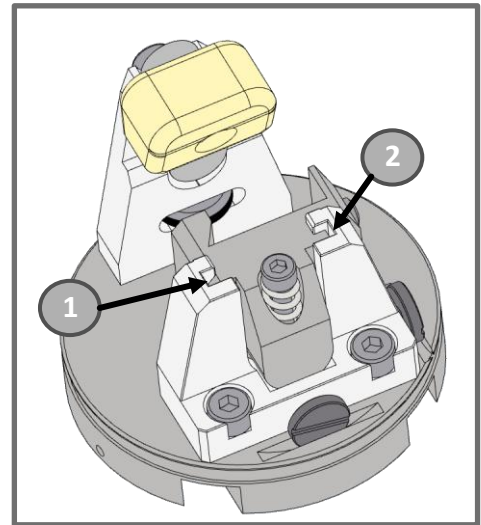

Figure 6-2



CAUTION! Use only a synthetic grease spray based on petroleum jelly. Avoid using conventional oils as they can cause an accumulation of dust and paper dust scraps on the cutting head guides and could leave traces of oil on the material being cut.

Maintenance of Lifting system of Material loading table (every 1-2 months)

- Open the magazine door with the special keys.
- Check that the cylinder rod (1) and the lifting screw (2) are well greased and clean, otherwise clean and refill grease in the cylinder (1) through the grease nipple (3) and manually apply the same grease on the whole screw.
- Close the door, set the left selector to “MAN” mode and holding the right selector (left and right) move the loading table up and down (Figure 4-4) to spread the grease.

Note. Pay Attention that there is nothing that can prevent the movement of the loading table.

- Open the door and make sure that everything is well greased.
- Close the door with the key.

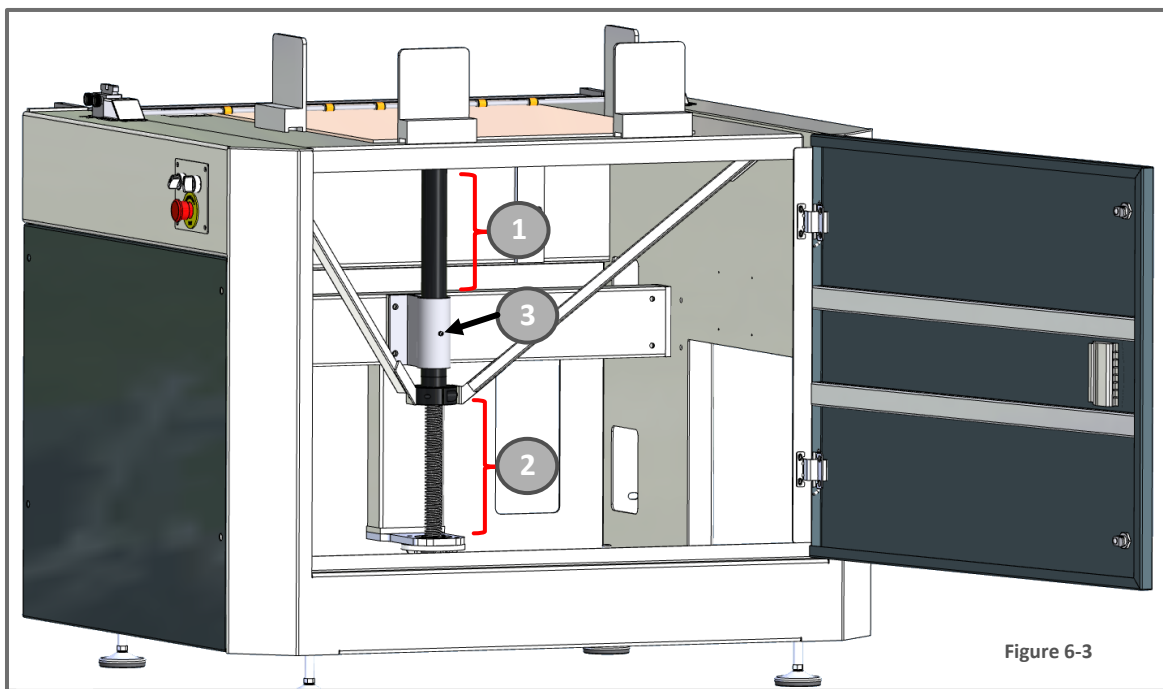
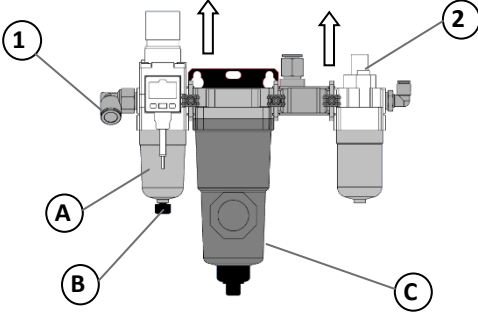
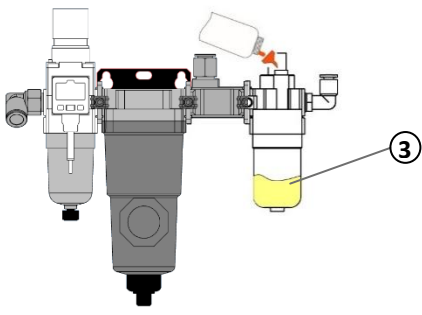
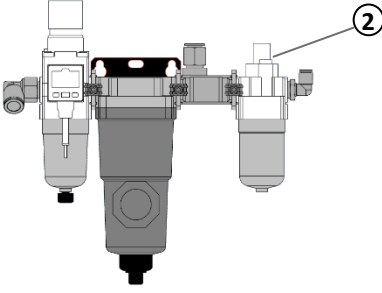
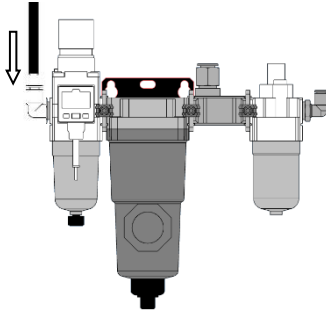

Figure 6-3



6.3 PNEUMATIC SYSTEM MAINTENANCE (EVERY 1-2 MONTHS)

Make sure the tanks (A)(C) of the air treatment unit located at the entry to the pneumatic circuit of the machine do not contain any water generated by the compressor and if so empty the tank releasing the valve (B). Check the oil level as well and if necessary re-fill it following the below steps;

	<p>Turn off the compressor (or close the pneumatic system valve if present near work zone) and remove the main air pipe (1).</p> <p>Unscrew the cap (2) of the tank</p>
	<p>Re-fill the tank with a funnel until the oil reaches the level indicated in the figure (3). An oil suitable for a pneumatic system with a viscosity of ISO VG 32 or max 46 is recommended.</p>
	<p>Re-insert the cap (4) and tighten gently. Attention! Over-tightening could break the tank's thread generating air and oil loss.</p> <p>The quantity of oil released in the pneumatic circuit is regulated by the manufacturer during the testing phase before the machine is shipped.</p> <p><u>NOTE! For sufficient lubrication, the oil flow adjustment knob must be between 1 and 2.</u></p>
	<p>Re-connect the air hose, turn the compressor back on (or open the pneumatic system valve if present near the work zone) and make sure there is no air leaking before operating the machine.</p>



CAUTION! Use only the oil suggested in the previous table to top off pneumatic system tank.



6.4 REPLACING THE CONVEYOR BELT

If it is necessary to replace the conveyor belt, proceed as follows for its replacement.

Make sure that the machine is turned off and disconnected from the mains power supply.

- Dismantle the two protection strips by removing the relative fixing screws (**Error! Reference source not found.** and REF_Ref61014396 \h **Error! Reference source not found.**)
- Remove the two protections bringing them over the worktop and extracting them from under the heads beam.

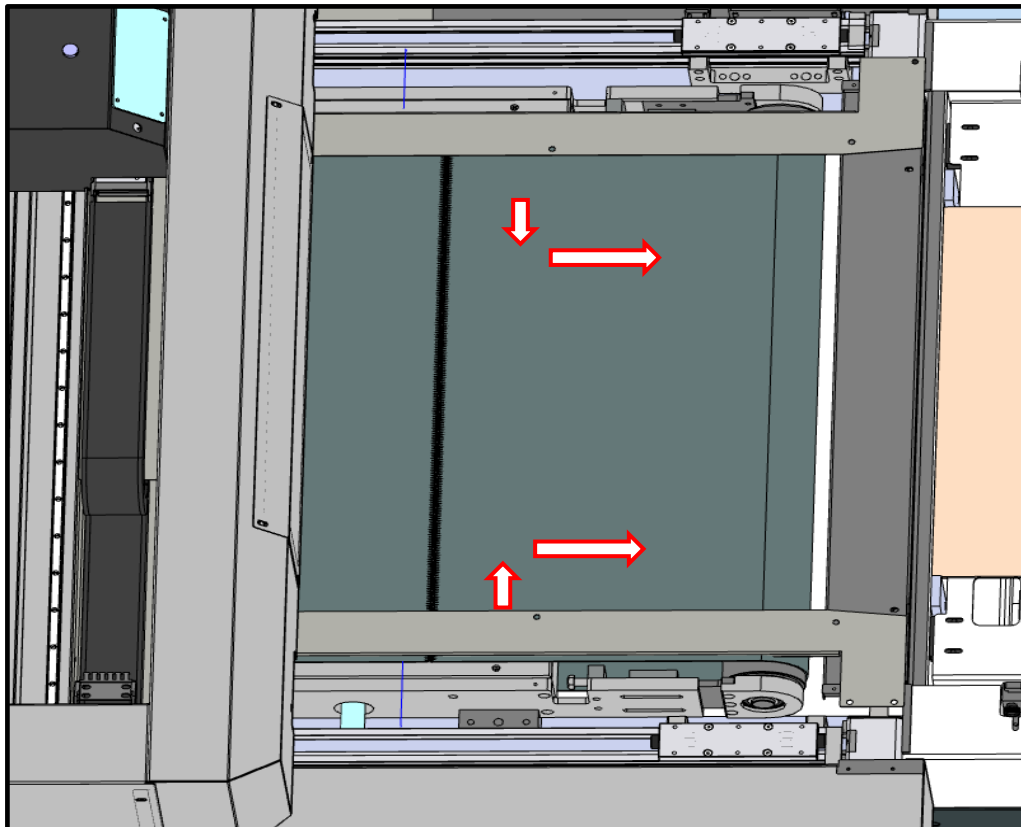

Figure 6-4





Note: To be able to reposition the pull roller in the same position, make a mark (4) on the plate (if not already present) as shown in figure 8-5.

Loosen the 4 locking bolts (1), then loosen the lock nut (2) and then the adjustment screw (3) until the head rests on the surface (Pay attention to the sensor cable).

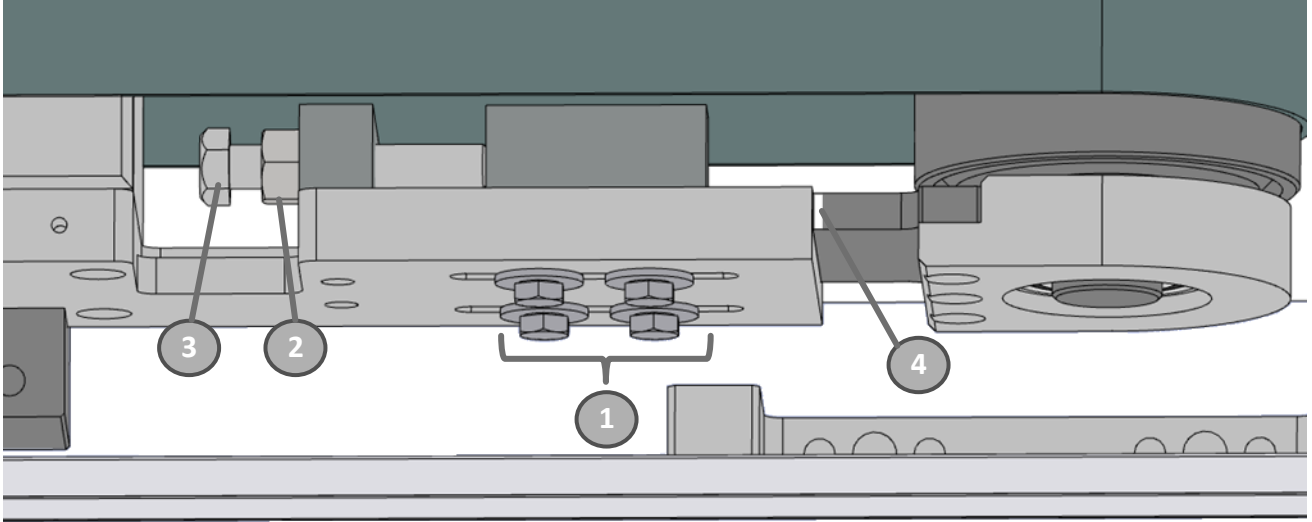

Figure 6-5

- Repeat the operation on the opposite side of the table.
- With the help of pliers or nippers, straighten or cut the hook of the junction pin of the old belt.

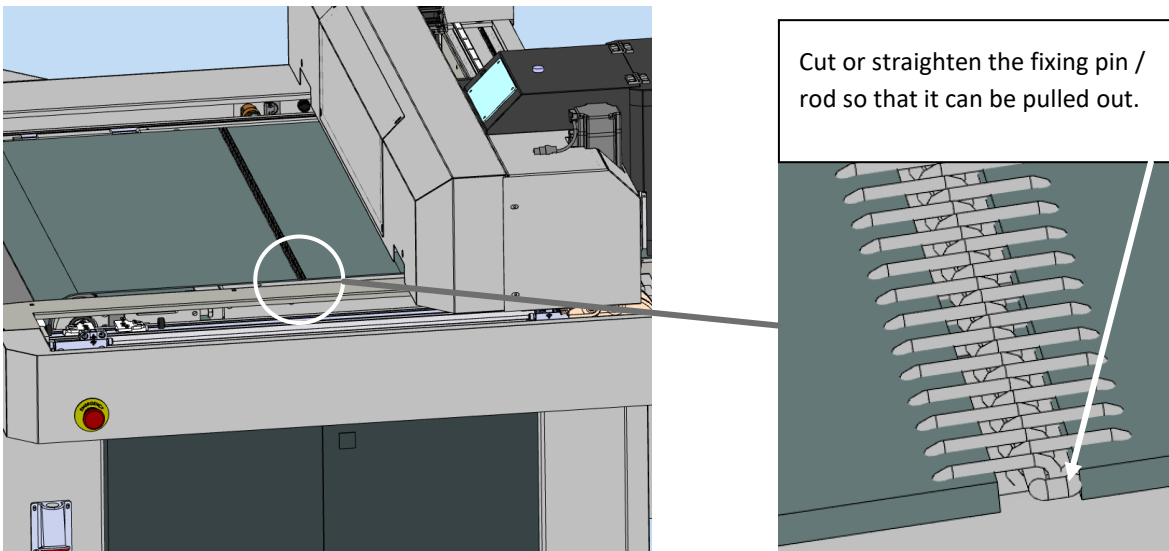

Figure 6-6



- Extract the coupling pin to open the drive belt.

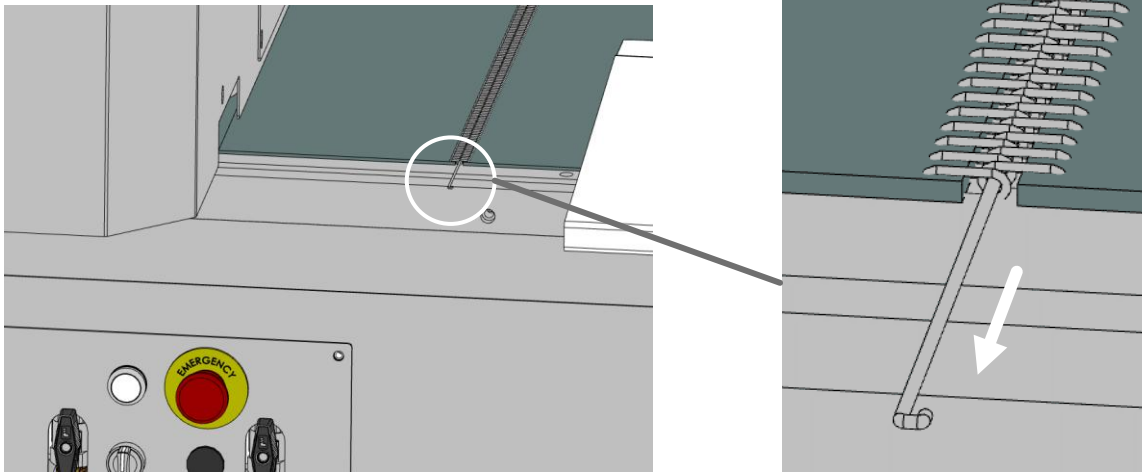

Figure 6-7

- Place the new conveyor belt on top of the table, making sure that the guides below match up.
- Insert the coupling pin in order to connect the old carpet with the new one.
- Pull the free side of the old belt so that when you take out the old one you will insert the new one.
- Once a complete turn of the table is done, remove the coupling pin and discard the old belt.
- Pull the two edges of the new belt and fit the junction links so that alternating they do not end with two consecutive links on the same side of the belt.
- Insert the joint pin and bend the two ends as shown in Figure 6-6.
- Tighten the adjustment screws (3) Figure 6-5 from both sides of the roller until the mark (4) reappears.
- Check that the tension of the new belt is correct, then tighten the 4 bolts (1) and the lock nut (2) Figure 6-5 on both sides of the roller.
- Re-tighten and refasten the two protection strips previously removed Figure 6-4, **Error! Reference source not found.** and **Error! Reference source not found.**
- Using the V-Studio Diagnostics, start the automatic carpet measurement procedure.



7 TROUBLE SHOOTING

This section relates to possible problems that could occur during normal use of the machine. For any problems not covered in this manual please contact your sales representative, your nearest Valiani dealer or the Valiani technical support.

7.1 CONNECTION PROBLEMS

The Ethernet connection error message reports when the V-Studio software is not capable of linking with the machine. There may be several reasons that could generate this issue;



Figure 7-1

- The Ethernet cable connecting the PC with the machine is disconnected or damaged.
- The machine IP setting is incorrect. (For software / machine connection and parameter settings, see the adjustments section of the software manual).
- The main switch on the electrical control panel is not in the "ON" position.
- Smart Cut process might be not close correctly and still running underneath. Please check thru the task manager.
- The PC has turned the some componets off after a long "stand-by" period. This interupt the connection with the machine and might require a PC reboot.. Check, and if necessary, change the Windows settings to avoid partially closing down the system on "Standby"



CAUTION! Always ensure that the Ethernet cable is connected correctly and that the machine is always switched on before opening V-Studio.



8 DECOMMISSIONING AND DISMANTLING

When dismantling or disposing of the machine it should always be noted that:

- The client, under 91/689/EEC directives, or byelaws in force in the relevant country, is responsible for the disposal of the machine and its components.



NOTE! Qualified people who have knowledge of the appropriate laws and methods to use should conduct the dismantling and re-cycling operations.



DANGER! During dismantling of the machine, ensure that the parts being removed are within limits for a workman to carry (max. 25 Kg) and that there is no risk of anything falling and causing injury.



DANGER! When dismantling the machine pay particular attention that it does not become unbalanced. This could be dangerous for anyone in the immediate vicinity whether involved, or not involved, in the dismantling operation.

- The machine should be dismantled in order to effectively separate the various materials used in its construction.
- Proceed with emptying the oil in the air pressure regulator ensuring that it is disposed of as necessary under EEC law or the law of the country prevailing in the country of disposal.



CAUTION: Discarding oil into the drainage system is prohibited.

- All plastic and electrical materials should be taken to authorised recycling organisations.
- Where possible recycle motors, transformers and electro-mechanical components otherwise take them to official industrial waste sites.
- All ferrous metals should be taken to authorised recycling centres.
- The standby batteries should never be discarded into the environment as they are classed as pollutants and therefore should be disposed of by authorised centres.

8.1 HAZARDOUS SITUATIONS

In the case of a fire use CO² extinguishers so as not to damage electrical components.

In the case of fire use powder extinguishers type ABC + Nitrogen to limit the damage in areas not containing electrical components.

9 DOCUMENTATION SUPPLIED WITH THE MACHINE

Il manuale istruzioni e manutenzione della macchina e' accompagnato dai seguenti documenti:

- V-Studio software manual.
- Vacuum pump manual
- Electrical system diagram.
- Warranty & replacement parts shipment form.



WARRANTY CONDITIONS

Valiani guarantees its cutting machines, purchased new from Valiani or an authorized dealer, for a period of one (1) year from the installation/activation of the product. This warranty covers the mechanical, pneumatic, electrotechnical, and electronic components according to the production specifications and is valid from the date of the machine's first power-on, automatically recorded by the machine's software system. The technical support service and free remote connection are also valid for one (1) year. All accessories purchased with or after the purchase of the cutting machine are guaranteed against defects for one (1) year from the purchase date of the product(s), as indicated on the delivery note or invoice, regardless of when they are eventually installed.

During the Warranty Period, Valiani will, at its discretion, repair or replace the machine or the accessory that does not comply with the Warranty without additional costs, with the exception of travel and labor costs relating to Valiani personnel sent to the site.

The repair, at Valiani's discretion, may involve software updates, replacement of components or boards with others of equivalent functionality, whether new or refurbished. Replaced components, accessories, batteries, or boards are covered by the remaining duration of the original warranty period. As such, the Warranty Period will not be extended in any way. The substituted machine, original accessories, and/or replaced mechanical and electronic components become the property of Valiani.

METHOD

To obtain warranty assistance, the buyer must contact Valiani no later than eight (8) days from the discovery date of the defect in materials, workmanship, or non-compliance with the specifications of the Product itself and before the expiration of one (1) year from the installation/activation of the machine or from the purchase date of the accessory as indicated on the delivery note or invoice.

In the event that a specific part of the machine is requested to be returned to Valiani or an authorized Valiani dealer, the product must be sent with shipping costs to be paid by the owner/customer, in accordance with Valiani's RMA procedures. This warranty will be void if the RMA procedures are neglected or not properly followed. In the case of a warranty replacement order with a request to return the defective part, if the buyer does not ship it back to Valiani within forty-five (45) days of receipt, Valiani will issue an invoice for each item replaced and not returned.

WARRANTY EXCLUSIONS

This warranty is not valid on consumable parts and if the origin of the fault is not attributable to product defects but to external factors such as, purely by way of example and not exhaustively:

1. Use that does not comply with the indications of the user manual (incorrect use), tampering, negligence, or neglect and in the case of alterations or repairs carried out by personnel not authorized by Valiani.
2. Use of accessories, software applications and peripherals (including but not limited to: batteries, USB adapters and power supplies), not manufactured, supplied, or expressly authorized by Valiani.
3. Use of blades or components not produced, supplied or expressly authorized by Valiani.
4. Connection to incompatible energy sources, supercharging the machine, or the connection to an earthing system not in accordance with the law.
5. Use of connection cables to the electric control unit of the Product that are elongated, modified, damaged or have been crushed or short-circuited.
6. When defects or damages are due to humidity, liquids, or other infiltrations.

In addition, this warranty will not apply if the serial number of the Product has been modified, deleted, duplicated, removed, or made illegible. Valiani reserves the right to refuse free assistance if the requested documentation cannot be provided or if the information is incomplete, illegible, or incompatible with the factory data.

DATA BACK-UP

Before sending your Product or a specific part of the machine for warranty service, please take note and backup all the data that you have entered for your Product, such as the library, the settings for the machine setup and any adjustments for cutting, as this data could be deleted during the repair or service operation.

OUT OF WARRANTY REPAIRS

In the event that the customer requests Valiani to perform a repair of the machine or a specific part of the machine beyond the Warranty Period, or if the Warranty cannot be applied due to the nature of the defect(s) or malfunction(s), Valiani, at its discretion, may carry out these repairs and charge for the costs incurred.



DECLARATION OF CONFORMITY



The manufacturer:

VALIANI S.r.l.

REGISTERED OFFICE:

Via delle Regioni, 305-307 – 50052 Certaldo [FI] - ITALIA
Tel. (+39) 0571 666 598
www.valiani.com – email: info@valiani.it

***Declares under our sole responsibility that the machine
has been made in compliance with the following directives***

- **Directive 2006/42/EC** of the European Parliament and of the Council on machinery.
- **Directive 2014/35/EU** of the European Parliament and of the Council on the harmonisation of the laws of the Member States relating to the making available on the market of electrical equipment designed for use within certain voltage limits.
- **Directive 2014/30/EU** of the European Parliament and of the Council on the harmonisation of the laws of the Member States relating to electromagnetic compatibility.
- **Directive 2011/65/EU** of the European Parliament and of the Council on the restriction of the use of certain hazardous substances in electrical and electronic equipment, as amended.

The technical documentation has been compiled in accordance with Annex VII A of Directive 2006/42/EC.

Person authorized to compile and keep the technical documentation:			
Name:	NICO	Surname :	VALIANI
Address	Via delle Regioni, 305-307	Country:	Certaldo [FI] - ITALIA
Corporate position:	Chief Executive Officer		



12 EXTERNAL DIMENSION

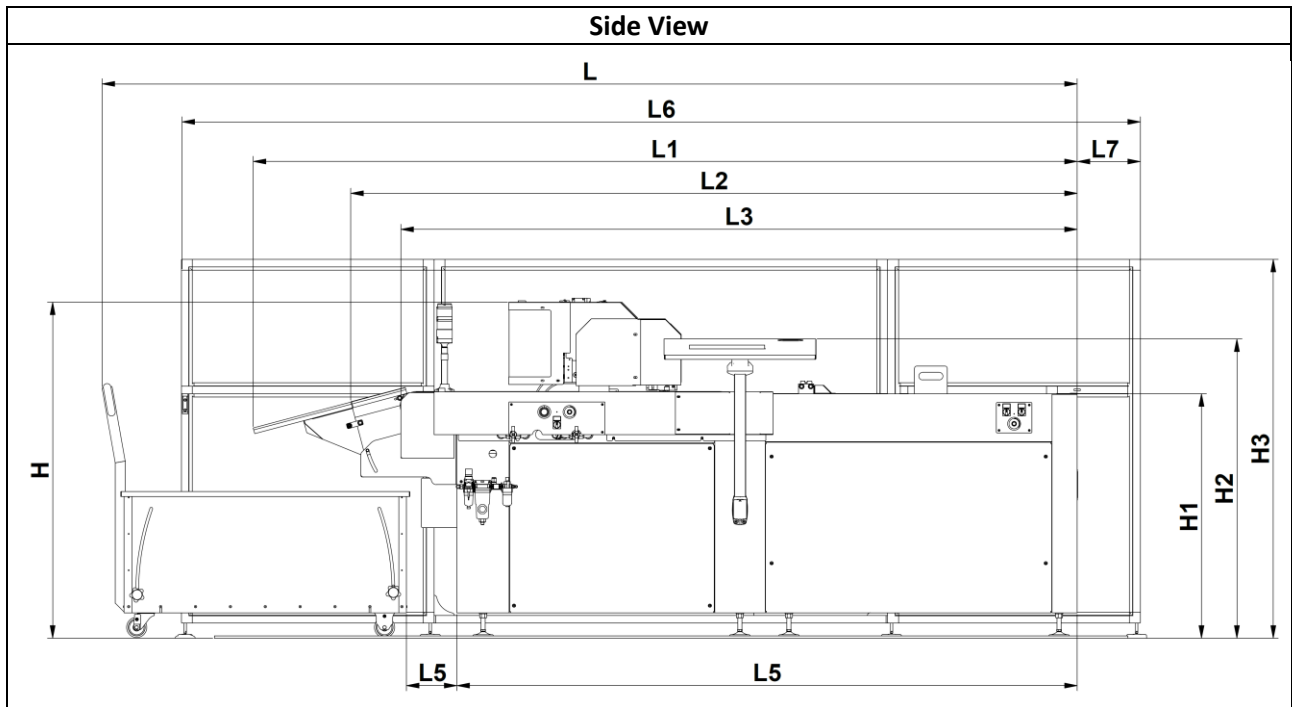

Model	L	L1	L2	L3	L4	L5	L6	L7	H	H1	H2	H3
V0708	3860mm 151.97"	3255mm 128.15"	2870mm 113"	2677mm 105.39"	2455mm 96.65"	200mm 7.87"	3795mm 149.41"	250mm 9.84"	1320mm 51.97"	955mm 37.6"	1245mm 213.4"	1500mm 59.05"
V0710	4370mm 172"	3515mm 138.4"	3130mm 123.23"	2935mm 115.55"	2710mm 106.7"			0mm 0"				

Note: L5= hypothetical measure

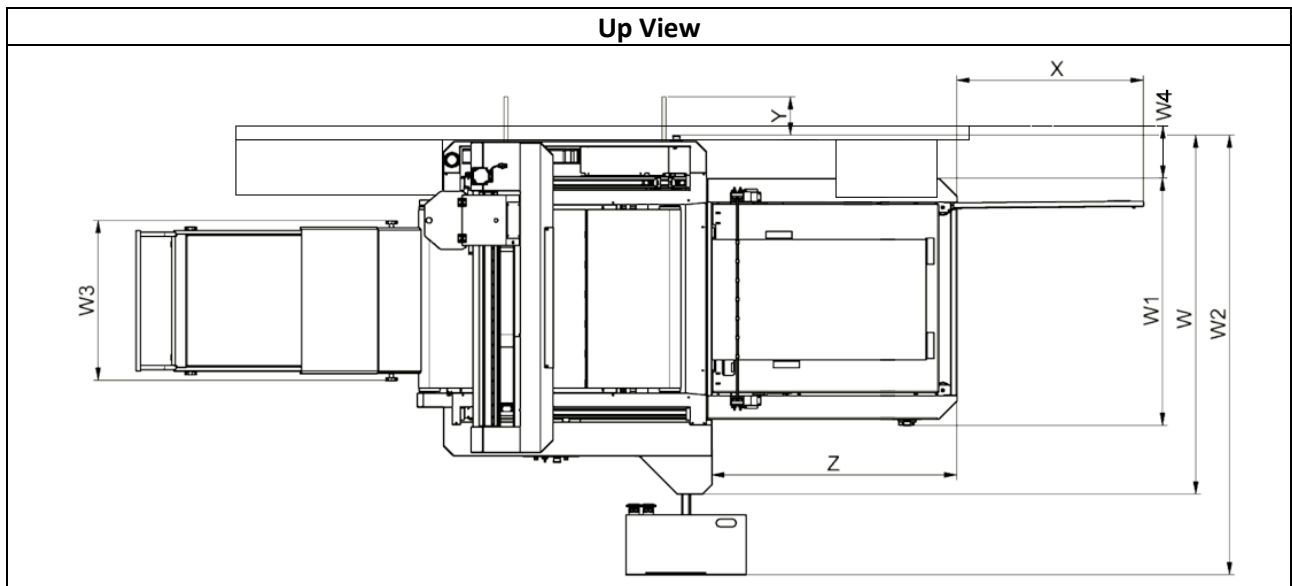

Modello	W	W1	W2	W3	W4	X	Y	Z
V0708	1790mm	1235mm	2190mm	800mm / 31.5"	224mm	930mm	190mm	1205mm
V0710	70.47"	48.62"	86.22"	930mm / 36.6"	8.82"	36.6"	7.48"	47.44"

Note: X = loader door opening dimensions, Y= electrical panel opening dimensions



Summa / **valiani**
your perfect cut

Valiani srl
Via delle Regioni 305
50052 Certaldo - Florence - Italy
info@valiani.com - valiani.com