

Summa / **valiani**
your perfect cut

INTEGRA

Instruction and Maintenance
Manual

INTEGRA

Summa / valiani
your perfect cut

SUMMARY

1	PREFACE.....	1
1.1	TO ENSURE PROPER AND SAFE USE.....	1
1.2	CONVENTIONS USE IN THIS MANUAL	1
1.3	SAFETY PRECAUTIONS (NOTE)	1
1.4	SAFETY PRECAUTIONS (DANGER).....	2
1.5	SAFETY PRECAUTIONS (CAUTION)	3
1.6	CEE REGULATION	3
1.7	NOTE ABOUT THIS MANUAL	4
1.8	SCOPE OF THE INSTRUCTION MANUAL	4
1.9	INFORMATION REGARDING TECHNICAL ASSISTANCE.....	4
1.10	SELECTION A POWER PLUG	5
1.11	DATA CABLES.....	5
1.12	WARRANTY CONDITIONS	5
1.13	GENERAL INFORMATION	5
1.14	TRADEMARKS.....	5
1.15	COPYRIGHT	5
2	WARNINGS	6
2.1	DATA & SAFETY LABELS ON THE MACHINE.....	6
2.2	DETAILS OF THE VARIOUS LABELS	7
2.3	SAFETY EQUIPMENT FITTED TO THE MACHINE	8
2.4	OPERATOR SAFETY MEASURES	9
2.5	OTHER RISKS	9
3	INTRODUCTION.....	10
3.1	OVERVIEW MACHINE	10
3.2	CUTTING TOOLS	11
3.3	PEN PLOTTING TOOL (OPTIONAL)	13
3.4	CREASING TOOL – BROWN (OPTIONAL)	13
3.5	MULTI-WALL CREASING TOOL – BROWN Ø60 (OPTIONAL).....	14
3.6	VERSATOOL (OPTIONAL)	14
3.6.1	<i>Interchangeable cutting heads (Optional)</i>	<i>15</i>
3.6.2	<i>Scoring / creasing tools (Optional).....</i>	<i>16</i>
3.7	ROUTER (OPTIONAL)	17
3.7.1	<i>Allowed cutting tools</i>	<i>18</i>
3.8	MATSTYLUS DELUXE SYSTEM DESCRIPTION (OPTIONAL).....	18
3.9	TECHNICAL DATA	19
3.10	INTENDED USE	19
3.11	IMPROPER USE OF THE MACHINE	20
3.12	BEFORE USE.....	21
4	DETAILS OF THE COMMAND CONTROLS	21
5	PREPARING FOR USE.....	22
5.1	POSITIONING THE PROTECTIVE POROUS WORKTABLE BOARD.....	24
5.2	TOOL LENGTH SETTER	25
5.3	CONNECTING ROUTER SUCTION.....	25
5.4	TANGENTIAL TOOL PREPARATION	26
5.5	OSCILLATING CUTTING TOOL PREPARATION (OPTIONAL)	27
5.6	X TYPE OSCILLATING TOOL PREPARATION (OPTIONAL)	28
5.7	PREPARAZIONE UTENSILE KISS-CUT (OPTIONAL)	28
5.8	PREPARING THE T-MARK TOOL	29
5.9	PREPARING THE CREASING TOOL.....	29
5.10	FITTING A CUTTING BLADE VERSATOOL (OPTIONAL)	30
5.11	REPLACING THE FOOT/ROLLER ON WHITE HEAD - VERSATOOL (OPTIONAL)	31

5.12	PREPARING THE ROUTER	32
5.13	ROUTER USE ADVICES	35
5.14	REPLACING CUTTERS.....	36
5.15	ASSEMBLING AND DISASSEMBLING MATSTYLUS DELUXE	37
5.16	INSTALLING A TOOL.....	37
5.17	ASSEMBLING THE VERSATOOL HOLDER	41
5.18	DISASSEMBLING THE VERSATOOL HOLDER.....	41
5.19	ASSEMBLING THE ROUTER AND SUCTION SYSTEM	41
6	ADJUSTMENTS	43
6.1	ADJUSTING THE VERSATOOL CUTTING DEPTH	43
6.2	ADJUSTING THE CUTTING PRESSURE OF THE KISS-CUT TOOL	43
6.3	ADJUSTING THE DOWN PRESSURE OF THE CUTTING HEAD	44
6.4	TOOL RESETTING PROCEDURE	45
6.4.1	<i>Resetting tool: 90° tangential, creasing, marker and versatool</i>	<i>45</i>
6.4.2	<i>Resetting the Oscillating tool.....</i>	<i>45</i>
7	ROUTINE MAINTENANCE	46
7.1	LEVELLING MDF BED (ONLY WITH ROUTER VERSION).....	46
7.2	CLEANING.....	47
7.2.1	<i>Router Cleaning procedure</i>	<i>48</i>
7.3	LUBRICATION	48
7.4	PNEUMATIC SYSTEM MAINTENANCE (EVERY 1-2 MONTHS)	49
8	TROUBLE SHOOTING	50
8.1	CONNECTION PROBLEMS.....	50
9	DECOMMISSIONING AND DISMANTLING	51
9.1	HAZARDOUS SITUATIONS	51
10	DOCUMENTATION SUPPLIED WITH THE MACHINE	51
11	WARRANTY EXTENSION	52
12	DECLARATION OF CONFORMITY.....	53
13	INTEGRA DIMENSIONS	54

1 PREFACE

Thank you for choosing the Integra. This machine uses stepping motors with encoder to achieve highspeed and high precision cutting. Thanks to the motorized head positioning Integra is ideal for milling operations on various material of different consistency without compromising the possibility of using it for cutting, creasing or writing.

To ensure high cutting quality and optimal productivity, be sure to read this User Manual thoroughly prior to use.



CAUTION! The device is for professional use and not for domestic use.

1.1 TO ENSURE PROPER AND SAFE USE

- To ensure the safe and correct usage of your machine, please read this manual carefully before use.
- After reading this manual keep it in a handy place for quick consultation if necessary.
- Do not allow children to touch, or be near, the machine.
- The following symbols/icons describe important points to safely operate the machine. Please ensure that our safety and general operating instructions are strictly followed.

1.2 CONVENTIONS USE IN THIS MANUAL

To ensure safe and accurate usage of the machine, as well as to prevent injury to persons and property, the security measures contained in this manual are classified in three categories as described below. Be sure to get a full understanding of the difference between each of the categories before reading the manual.

 Note	These are warnings to guide and optimize actions by the operator, or to better highlight the characteristics of the machine.
 Danger	This category provides information that, if ignored, could result in serious injury to the operator.
 Caution	This category provides information that, if ignored, could result in injury to the operator and/or damage to the machine.



1.3 SAFETY PRECAUTIONS (NOTE)











Note

When using the cutting tool, take care not to set the blade more than necessary. An overly blade set-up might damage the cutting slip-mat and adversely affect the cutting quality.

1.4 SAFETY PRECAUTIONS (DANGER)

 Danger	
Do not touch the rollers or moving parts such as the carriage while cutting or plotting is in progress. Such action may result in injury	
Be sure to ground the earth terminal. If the cutting plotter is not grounded, the operator could suffer an electric shock in the event of current leakage.	
Keep your hands, hair, etc., away from the rollers or moving parts such as the carriage even if the machine is stopped, as it may suddenly start moving when data is received. Such action may result in injury.	
Do not disassemble, repair, or modify the machine. Such actions may result in an electric shock or create a fire hazard due to current leakage. Contact with the high-voltage parts within the cutting plotter may also cause an electric shock. If the machine requires repairs, please contact your sales representative or your nearest vendor for advice.	
Do not connect the machine to a non-rated power supply. The use of a different supply voltage may result in an electric shock or create a fire hazard due to current leakage.	
Do not use the machine in a location where it might be exposed to water, rain, or snow. Such locations may cause electric shock or create a fire hazard due to current leakage.	
If the machine generates smoke, overheats, emits a strange smell or otherwise functions abnormally, do not continue using it. Turn off the power and unplug the power cord from the electrical socket. Use of the cutting plotter in such a condition may result in a fire hazard or electric shock. After confirming that smoke is no longer being emitted, contact your sales representative or nearest vendor for repairs. Never attempt to perform repairs yourself. Repair work by inexperienced personnel is extremely dangerous.	
Do not allow dust or metal scraps to adhere to the power plug. A dirty power plug may result in electric shock or create a fire hazard due to current leakage.	
Do not use the power cord if it is damaged. Use of a damaged cord may result in electric shock or create a fire hazard due to current leakage. Replace the power cord with a new one.	
Be careful when handling the blades or the cutters. By touching them with your bare hands may cause injury. Always wear gloves when handling any sharp items. Note. The router is normally cool down by air, however after a long use it might get very hot, therefore we recommend wearing protection gloves to prevent hand burns.	
The machine while using oscillating tools, router and dust aspirator emits a sound pressure higher than 78 dB (A), for which the use of PPE is required.	

1.5 SAFETY PRECAUTIONS (CAUTION)

 Caution	
Do not use or store the machine in a location exposed to direct sunlight or the direct draft of an air conditioner or heater. Such locations may impair the performance of the cutting plotter.	
Do not use the machine in an excessively dusty or humid location. Such locations may impair the performance of the cutting plotter.	
Do not place any receptacle containing water or other fluid on top of the cutting plotter. Fluid falling inside the cutting plotter could cause electric shock or create a fire hazard due to current leakage.	
Do not use the cutting plotter in a location subject to excessive mechanical vibration or electrical noise. Use in such locations may impair the performance of the cutting plotter.	
When disconnecting the power cord or interface cable, do not pull on the cord/cable. Such action will damage the cord/cable, resulting in a fire hazard or, possibly, an electric shock.	
Do not clean the cutting plotter using volatile solvents such as thinners or benzene. Such actions may impair its performance.	
Provide sufficient space around the cutting plotter so that it does not strike any objects in its vicinity during cutting or plotting. Such contact may cause cutting or plotting to go out of alignment.	

1.6 CEE REGULATION

This manual has been written in accordance with the directions of CEE DIRECTIVE 2006/42/CE as detailed in the machine design definition. User instructions are an integral part of the machine. The criteria used for writing comply with the indications of the EUROPEAN STANDARD EN - 292 and, in particular, the point related to USER INSTRUCTIONS (instructions, general requirements and nature of the instructions).

1.7 NOTE ABOUT THIS MANUAL

No part of this publication may be reproduced, stored in a retrieval system, or transmitted, in any form or by any means, without the prior written permission of the Construction Company.

- Product specifications and other information contained in this document are subject to change without notice.
- Although every effort is made to provide complete and accurate information, please contact your sales representative or the nearest dealer if you find any incorrect or unclear information or wish to make any other comments or suggestions.
- Construction Company assumes no liability for damages resulting from incorrect use of the machine.

This instruction and maintenance manual is essential for the technician who will install and operate the machine for the first time. It also provides all the information needed to properly prepare the operator for using, and performing proper maintenance, on the machine. The instruction and maintenance manual is essentially divided into:

- Cover with the name of the machine
- Summary
- Preface
- Manufacturer's details and machine identification
- Instructions for the transportation, installation and use of the machine
- Machine maintenance instructions

1.8 SCOPE OF THE INSTRUCTION MANUAL

This instruction manual is an essential part of the machine and its scope is to provide all the information necessary to:

- Safely move a packed, or unpacked, machine.
- Correctly install the machine.
- Safely use the machine
- Safely and correctly carry out machine maintenance.
- Decommission and dismantle the machine with respect to the laws in force and the environment.

The instruction manual should be handled with care, using clean hands, and should not be placed on dirty surfaces. It should be protected from humidity, heat and used carefully so as not to damage its contents. Under no circumstances should any of its contents be removed or modified. Should the manufacturer make any changes to the machine he will provide new documentation if necessary.

1.9 INFORMATION REGARDING TECHNICAL ASSISTANCE

The machine is covered by a guarantee as detailed in general conditions of sale. If, during the guarantee period, there are any fault with the machine or with the way it works the manufacturer will, after identifying the problem, conduct repairs or replace of any faulty parts deemed necessary. Unauthorised repairs, or the use of parts not provided by the Construction Company, will render the guarantee void and cancel any responsibility for damage caused by the machine as a consequence of unauthorised repairs or the use of unauthorised parts. For these reasons we strongly advise our clients to always call their sales representative, their nearest vendor or technical assistance department at Construction Company for advice.

1.10 SELECTION A POWER PLUG

Integra is supplied with a power cord only. The appropriate three phase plug must be purchased directly by the customer. Please buy one locally that complies with your national standards.

1.11 DATA CABLES

Please note that the maximum length of single USB cable cannot exceed 5 meters. Should a cable longer than 5 meters be needed please use signal repeaters for USB cables so as not to lose data signal strength between the computer and the machine.

1.12 WARRANTY CONDITIONS

The Construction Company guarantees that its products are soundly made and are free of manufacturing defects. For warranty details please refer to the specific warranty document supplied with this manual.

1.13 GENERAL INFORMATION

Carefully following the assembly, usage and maintenance standards described in this manual will ensure lasting performance and protect your investment. We suggest that you read and follow the recommendations carefully before machine start-up. We are available to offer any assistance that you may require. Please remember that non-observance of the advice and instructions included in this manual will, or could, result in the loss of warranty. As part of its continuing quality improvement program, the Construction Company reserves the right to carry out modifications it believes to be necessary. For further details or any eventual problem, please contact us.

1.14 TRADEMARKS

All trademarks mentioned belong to their owners, third-party brands, product names, trade names, corporate names and companies mentioned herein may be the trademarks of their respective owners or registered trademarks of other companies and have been used for purposes of explanation and the owner's benefit, without implying a violation of copyright law.

1.15 COPYRIGHT

All the material contained in this manual is owned by the vendor and may not be reproduced in full, or in part, without prior written consent from the vendor.

2 WARNINGS

2.1 DATA & SAFETY LABELS ON THE MACHINE

The machine is fitted with various labels to show either data or safety concern areas for the operator. Referring to the photograph below these are:

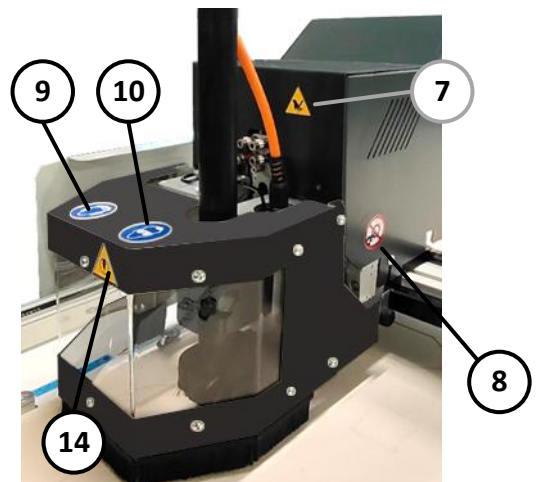
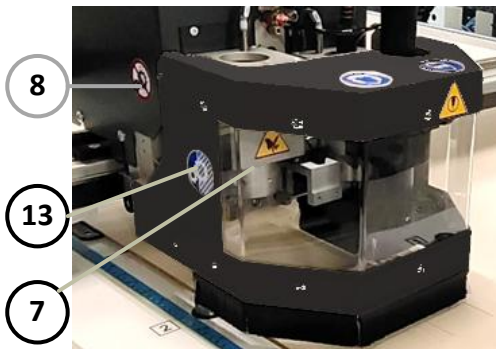
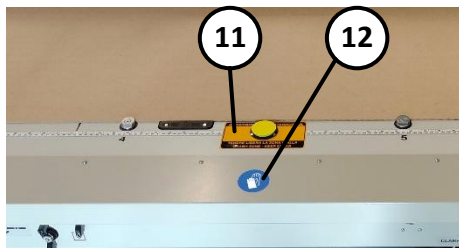
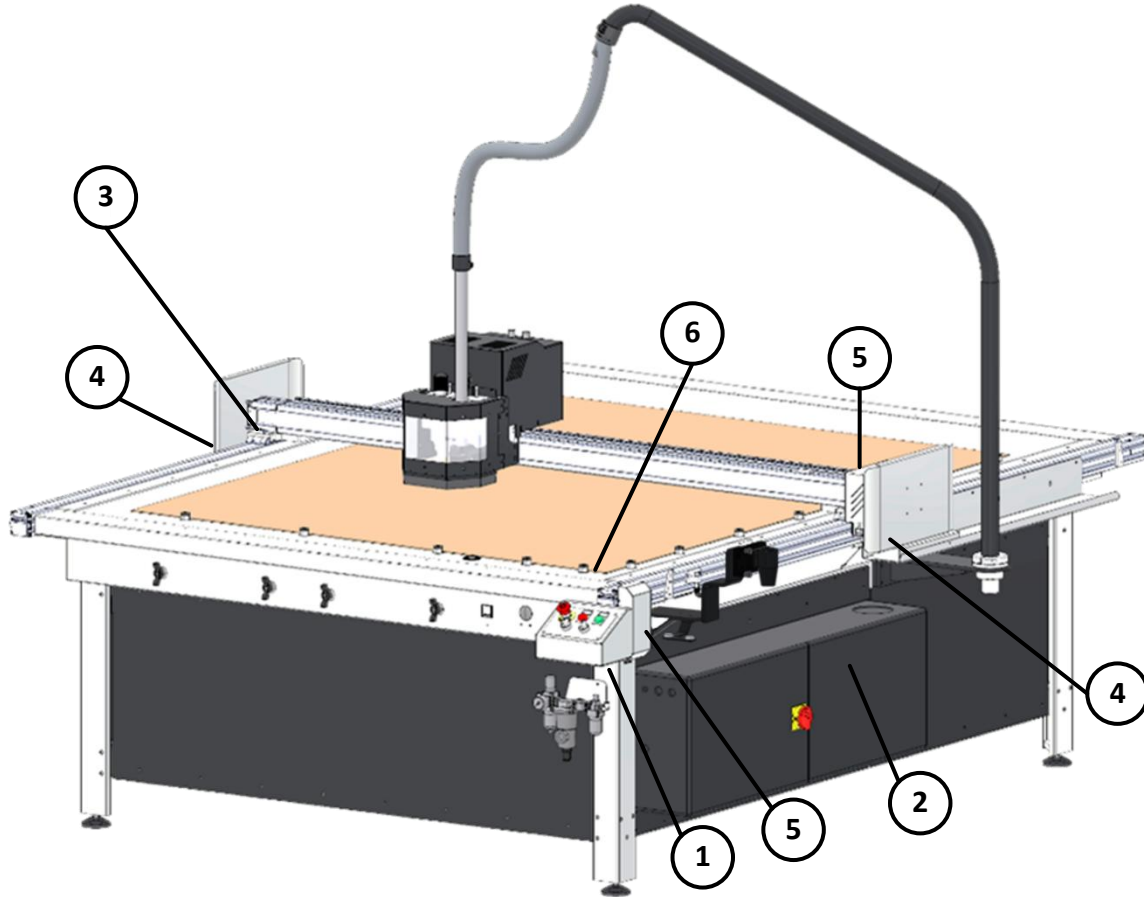

Figure 2-1

2.2 DETAILS OF THE VARIOUS LABELS

<p>1</p> 	<p>2</p> 
<p>3</p> 	<p>4</p> 
<p>5</p> 	<p>6</p> 
<p>7</p> 	<p>8</p> 
<p>9.</p> 	<p>10.</p> 
<p>11.</p> 	<p>12.</p> 
<p>13.</p> 	<p>14.</p> 

- LABEL 1:** Plate showing manufacturer data, model, year, serial number, weight, electrical and pneumatic information of the machine.
- LABEL 2:** Adhesive label: detailing the dangers of working with electrical equipment.
- LABEL 3:** Adhesive label: Hand Entanglement / Rotating Gears warning.
- LABEL 4:** Adhesive label: Moving parts warning.
- LABEL 5:** Adhesive label: Rotating gears warning.
- LABEL 6:** Adhesive label: Hand crash warning.
- LABEL 7:** Adhesive label: Hand cut warning.
- LABEL 8:** Adhesive label: Do not remove protection while machine is on.
- LABEL 9:** Adhesive label: Wear hearing noise protection
- LABEL 10:** Adhesive label: Wear protective eyeglasses
- LABEL 11:** Adhesive label: "Warning, Crash zone – Keep clear".
- LABEL 12:** Adhesive label: Wear protective gloves.
- LABEL 13:** Adhesive label: Keep safeguard protection on, when running the machine.
- LABEL 14:** Adhesive label: Moving tool hazard.

2.3 SAFETY EQUIPMENT FITTED TO THE MACHINE

The machine is equipped with various safety devices and an emergency stop button, to the drivetrain, that protects the operator from possible injury resulting from contact with moving parts. Two types of safety protection are provided:

- Mobile protection.
- Fixed protection.

Any mobile safety devices are fixed on the machine by screws. These devices are fitted to areas of the machine where there are moving parts, blades or sharpen tools or in any area that might generate possible danger to the operator while using the machine. The protective devices are made of polycarbonate or metal (depending on the models), secured by screws and removable only using wrench or allen keys.

The safety devices fitted on the machine are as follows:

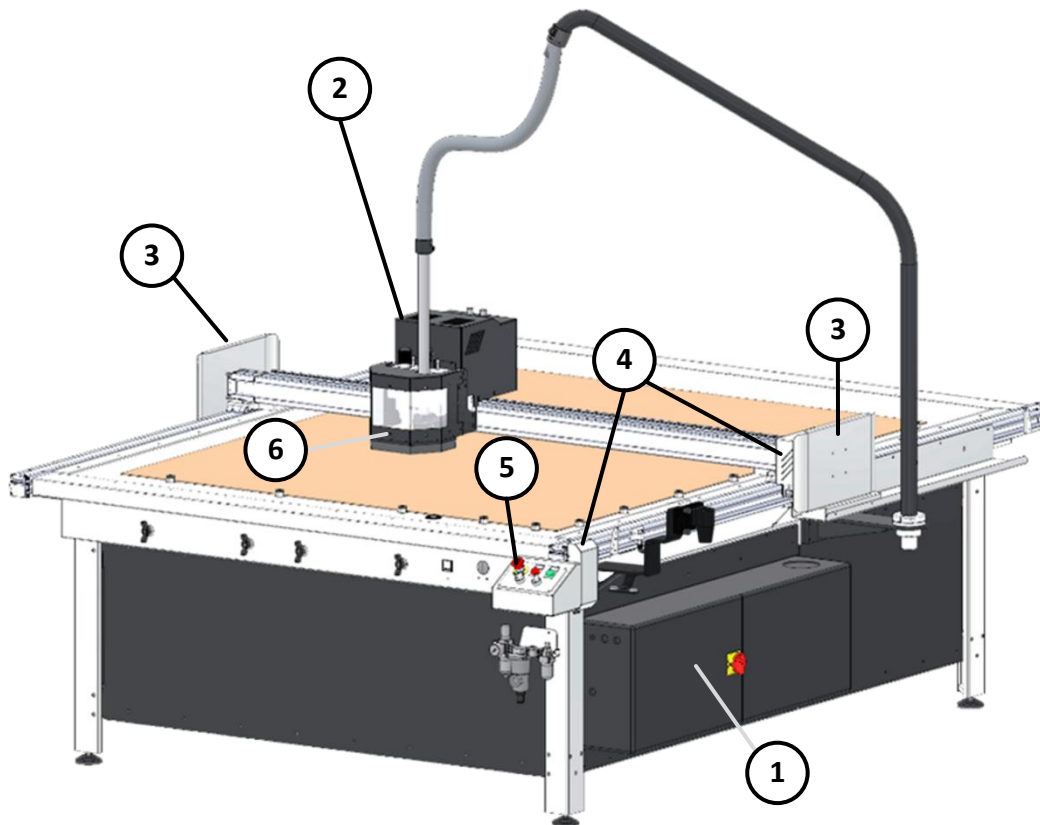

Figure 2-2

- 1 Electrical Control Panel door (mobile protection closed by key).
- 2 Cutting head unit cover (fixed protection, secured with screws).
- 3 Mobile gantry protection (fixed protection, secured with screws).
- 4 Motors covers (fixed protection secured with screws).
- 5 Emergency stop button (see section 4 of this instruction manual).
- 6 Tool safeguard protection (mobile protection).



DANGER! Before switching the machine on, please check that all the safety covers are closed. Ignoring these precautions could result in serious injury to the operator, to anybody nearby or potentially damage the machine. Under no circumstances use the machine with the mobile safety covers open or the fixed covers removed.

2.4 OPERATOR SAFETY MEASURES

According to the type of work conducted with the machine some maintenance work will require the operator to wear gloves and safety glasses.

While servicing the machine, it is recommended to use personal protective equipment:

- Gloves while cleaning the machine.
- Gloves with any operation involving the tools, cutting blades or the router cutters.
- Safety glasses while performing maintenance and inspection of the compressed air system.

2.5 OTHER RISKS

This section has the scope of identifying the other risks associated with using the machine so that operators can identify situations in which they should take particular care when doing specific tasks.

- During installation take the outmost care when positioning the machine on its base, where there could be a risk of you losing your balance and dropping the worktable. Only people directly involved in the assembly operation should be allowed into the assembly area.
- Be very careful; to avoid possible injury due to the incorrect handling of the blades and the cutters while performing any tasks on the tool or on the blade itself, always wear safety gloves.
- To avoid possible injury to hands or fingers do not to place your hands on the worktable, under the cutting head carriage or the cutting head while the machine is working.
- Wait for at least a minute after switching the machine off before opening the electrical box for maintenance so that any residual electrical energy has had time to dissipate.
- Even if the machine is stopped the "EMERGENCY" button must be pressed to put the machine into "suspend mode" before doing any maintenance work (including adjustments).



NOTE! Before doing any maintenance to the electrical system the operator must read this manual and refer to the circuit diagrams provided.



NOTE! This equipment has been tested and found to comply with the limits for a Class A digital device, pursuant to part 15 of the FCC Rules. These limits are designed to provide reasonable protection against harmful interference when the equipment is operated in a commercial environment. This equipment generates, uses, and can radiate radio frequency energy and, if not installed and used in accordance with the instruction manual, may cause harmful interference to radio communications. Operation of this equipment in a residential area is likely to cause harmful interference in which case the user will be required to correct the interference at his own expense.

3 INTRODUCTION

The Integra is a cutting system designed to process materials of greater consistency and thickness typical of the world of signage and packaging industry.

The Integra is equipped with two independent and modular tool stations that prevent interruption during the work cycle, it is also designed to be mount a router which allows milling operation on various material.

The Integra, with a combined vacuum assisted table and a new fold-away clamping system, provides incomparable working flexibility over a wide range of materials and unparalleled accuracies to meet today's production challenges.

The software provided with the machine will guide the operator in choosing the correct tool and using it properly.

3.1 OVERVIEW MACHINE

The Integra is made from a tubular steel frame enclosed by metal panels which give good rigidity. The machine is supplied with a standard tangential drag knife (90° - Grey) cutting head which will cut a wide range of soft material to a maximum thickness of 5 mm (0,196"). Through the software the operator will set the depth and the cutting speed and in the case of the router the vertical feed speed and the rotation speed of the tool as well.

Integra can be equipped with a camera (A) Figure 3-1 and a software (**OptiCrop**) for crop mark recognition. This combination of device/software allows to perform contour cut on previously printed materials.

The materials can be retained:

- Mechanical locking by pneumatic clamps (B)
- Using suction (C)
- Combination of both

The vacuum table is divided into various sectors can be enabled or disabled according to the needs of the moment by using special manual valves regulators (1, 2, 3, 4), see chapter 4.

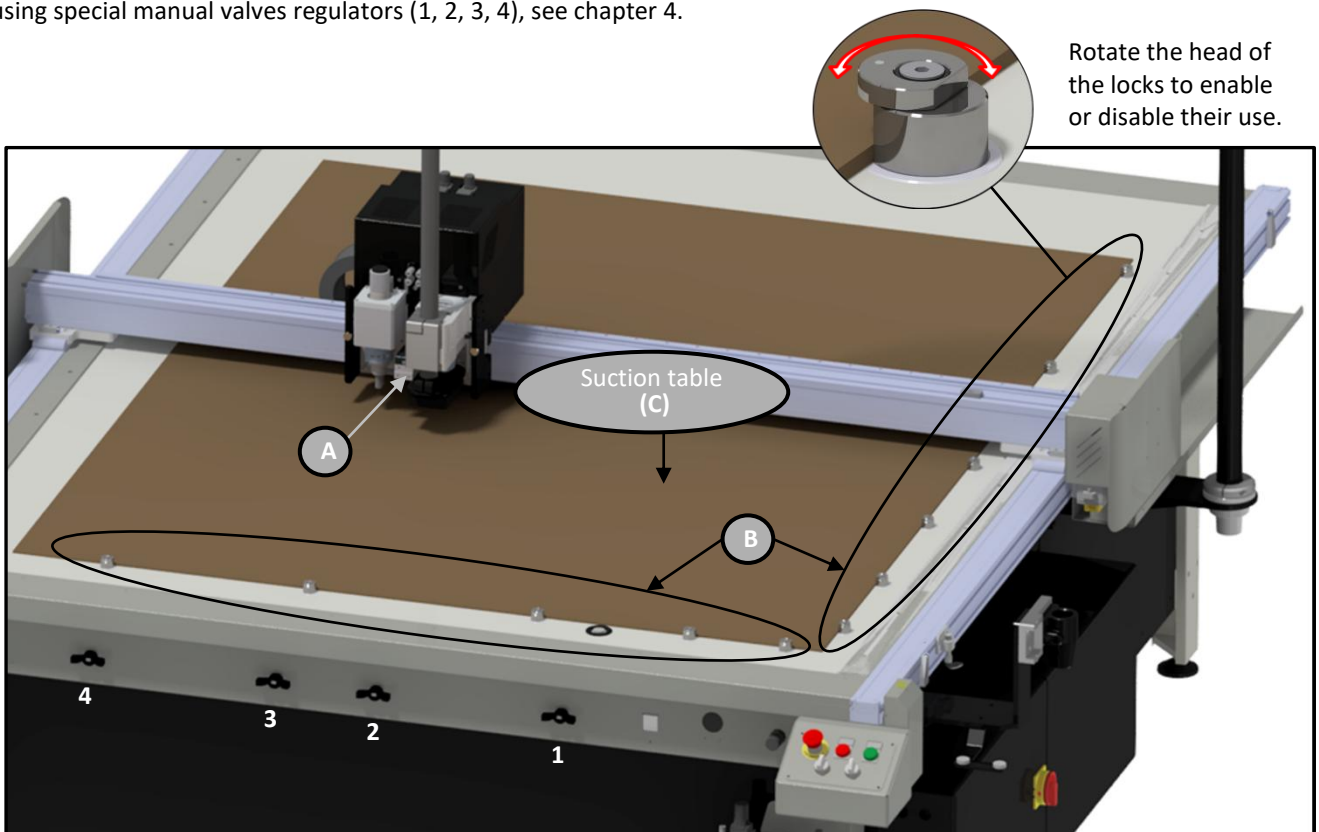

Figure 3-1

3.2 CUTTING TOOLS



NOTE! The purchase of a tool separately from the machine requires, only on first use, the execution of a reset procedure. See cap.6.4

The machine is equipped with two tool holder and a support for a third fixed tool. This modularity in combination with the possibility to change one of the tool during any cutting process makes Integra capable to perform a greater variety of cuts, on different materials

Grey – Tangential Drag Knife (included): The tangential cutting tool allows you to cut a wide variety of materials with a maximum thickness of 5mm (0.196”). The use of drag knife allows you to perform cuts even at high speed.

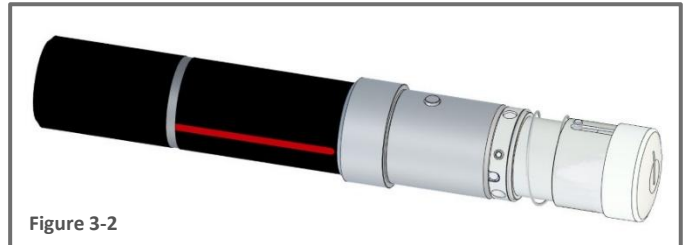

Figure 3-2

Depending on the blade holders and the kind of job the machine is supposed to perform the following blade might be available:

	Code	Description	Fields of use
	L100	Multipurpose Blade. 50° Angle	Universal knife for materials such as paper, cardboard, thin plastic, soft PVC, Foam Board.
	L100B	Multi-purpose Blade. 38 °Angle for a more precise cut on small radius.	Universal knife for materials such as paper, cardboard, thin plastic.
	L1W40	Carbide multipurpose blade for a longer sharpening duration. 50 ° angle.	Long lasting blade ideal for very abrasive materials. (See L100)
	L1W46	Carbide multipurpose blade for a longer sharpening duration and with a 38 ° angle for greater precision on cuts with a reduced radius.	Long lasting blade ideal for very abrasive materials. (See L100B)
	002156	Multipurpose T16 Blade (38° Angle)	Universal knife for soft materials. To make sharp edges.
	002157	Multipurpose T17 Blade, with a tighter angle for greater precision on cuts with a small radius. (25° Angle)	Sole leather, cardboard, thin polyester. To make sharp edges.

Note: For any particular need, other blades might be available. Please contact your local dealer, or the manufacturer for further information.

Black - Oscillating Cutting Knife (Optional):

The oscillating cutting tool is operated by compressed air and it is suitable for both soft and rigid materials. The tool reaches a number of 9000 oscillations per minute (rpm) with a stroke of 8mm (0.315”). Depending on the blade used, it can cut up to 20 mm (0.787”) thick *. Minimum use pressure: 7 Bar
* With TC25 Blade.



Figure 3-3

Depending on the work to be performed, the following blades are available:

	Code	Description	Fields of use
	002720	TC 5mm Blade	Gasket material, solid cardboard, foam cardboard, foamboard with paper surface, foamed materials, soft foam panels, corrugated cardboard, packaging material, honeycomb cardboard.
	001899	TC 10mm Blade	
	001898	TC 15mm Blade	
	001897	TC 25mm Blade	

Note: For particular needs, other blades might be available. Please contact your local dealer, or the manufacturer for further information.

INTEGRA

Black X - Oscillating Cutting Knife - Type X (optional): The oscillating cutting tool type X is operated by air compressed and it is suitable for soft and thin material. The tool reaches a number of 16000 oscillations per minute (rpm) with a stroke of 8mm (0.315"). Depending on the blade used, it can cut up to 20 mm thick * Use pressure 8 Bar.

*With 0.64x38mm (0.025"x 1.49") blade.



Figure 3-4

Depending on the work to be performed, the following blades are available:

	Code	Description	Fields of use
	002156	Multipurpose T16 Blade (38° Angle)	Universal knife for soft materials. To make sharp edges.
	002157	Multipurpose T17 Blade, with a tighter angle for greater precision on cuts with a small radius. (25° Angle)	Sole leather, cardboard, thin polyester. To make sharp edges.
	002445	T18 Heavy-Duty Blade	Very rigid materials, sole leather, asbestos free, tang graphite, for thickness up to 5 mm.
	002447	T19 Blade – Soft Rubbers	Soft rubbers up to 12 mm thick.
	002733	T21 Blade – Double Edge HD Blade	

Note: For any special need, other blades might be available. Please contact your local dealer, or the manufacturer for further information.

Pink – Kiss-Cut Tool (Optional): With mechanically-controlled knife pressure, this tool is specifically designed for kiss-cutting material down to its liner up to 1.2 mm thick.

This tool also includes an adjustable nose piece for precise depth control. Depending on the materials the following blades are available.

	Code	Description	Use
	003110	TK36° blade kit (5pcs)	Standard Tangential Knife 36° - Max cutting thickness 0.25 mm
	003111	TK60° Blade	Tangential Knife 60° - Max cutting thickness 1.2 mm
	003112	36° Double- tip blade	Tangential Double Tip Knife 36° - Max cutting thickness 0.25 mm
	003113	45° Double Wedge Blade	Tangential Knife 45° wedge 40/25° - Max cutting thickness - 1 mm



Figure 3-5

3.3 PEN PLOTTING TOOL (OPTIONAL)



NOTE! The purchase of a tool separately from the machine requires, only on first use, the execution of a reset procedure. See cap.6.4

Gold - T-Mark Tool: T-Mark is a tool that allows writing or drawing on the material, creating dynamic drawing or text on the cardboard patterns. The Tool is supplied with a pen cartridge 0.4mm / 0.157" (FISHER pressurized, H=76mm/2.99", Ø4.8mm/1.89", ball 1.1mm/0.43").



Figure 3-6

3.4 CREASING TOOL – BROWN (OPTIONAL)



NOTE! The purchase of a tool separately from the machine requires, only on first use, the execution of a reset procedure. See cap.6.4

Brown – T-Creasing Tool: The Packaging Tools set, consists of one head (Tool holder) with an assortment of creasing wheels of various geometry, which have been designed to process a wide range of materials, for those who need to crease folding cardboard, flute board, corrugated board and coroplast.

Creasing can be performed either in Pressure Mode or Position Mode. In Position Mode, the creasing wheel is lowered to a set depth thru the second head's knob and this method is well suited for creasing corrugated carton preventing to break the flute. Pressure Mode is commonly used for folding cardboard; however, a hybrid mode might be needed with other materials.

The various wheels can be exchanged on the head without any additional tools, therefore minimizing delay during the

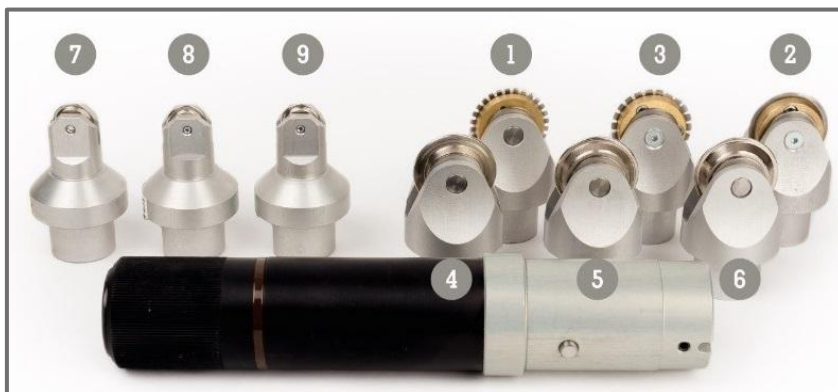

Figure 3-7

working process.

The creasing set consists of 9 tools each with different characteristics:

- | | | |
|----|--|--|
| 1. | Perforating tool Ø 32mm /1.26" | Serrated cut wheel, 2-1mm / 0.078-0.039" step. |
| 2. | Cutting tool Ø 32 mm /1.26" | Metal wheel, for Cut-crease |
| 3. | Perforating tool Ø 32 mm /1.26" | Serrated cut wheel, 3-1mm / 0.118-0.039" step. |
| 4. | Creasing Wheel Ø 32 mm /1.26" | 3 pt (1.1mm / 0.043") round crest, Flute F/E |
| 5. | Creasing Wheel Ø 32 mm /1.26" | 4 pt (1.5mm / 0.059") round crest, Flute B/C |
| 6. | Creasing Wheel Ø 32 mm /1.26" | 6 pt (2mm / 0.078") round crest, Flute A/B/Double |
| 7. | Creasing Wheel Ø 16 mm /0.63" | 2 pt (0.7mm / 0.0275") round crest, cardboard 150-300 gsm. |
| 8. | Creasing Wheel Ø 16 mm /0.63" | 3 pt (1.1mm / 0.043") round crest, cardboard 150-300 gsm. |
| 9. | Creasing Wheel Ø 16 mm /0.63" | 4 pt (1.5mm / 0.059") round crest, cardboard 250-400 gsm. |

3.5 MULTI-WALL CREASING TOOL – BROWN Ø60 (OPTIONAL)

Brown – Creasing Wheel Ø60: It consists of a tool holder with a bundle of creasing wheels of various geometries specific for single and multiple flute corrugated cardboards.

Creasing can be performed either in Pressure Mode or Position Mode. In Position Mode, the creasing wheel is lowered to a set depth thru the second head's knob and this method is well suited for creasing corrugated carton preventing to break the flute. Pressure Mode is commonly used for folding cardboard; however, a hybrid mode might be needed with other materials.

The different wheels can be changed from the head without the need of any additional tool, thus minimizing the delay during the work process.

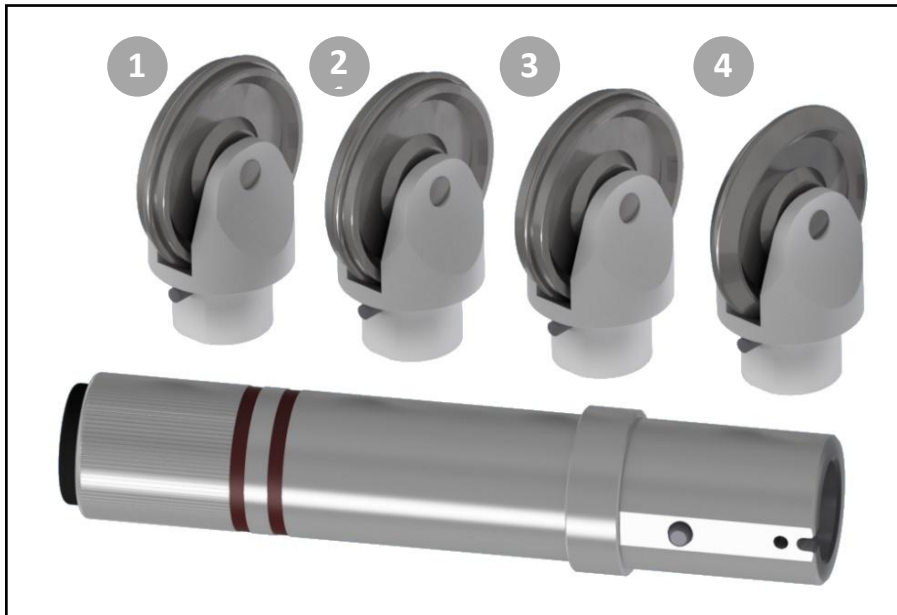

Figure 3-8

There are four types of available wheels upon request, each one with different characteristics:

1. **Creasing Wheel Ø 60 mm:** 3x2mm 8pt (1.1 mm) round crest, Flute type F/E
2. **Creasing Wheel Ø 60 mm:** 3x1.5mm 8pt (1.5 mm) round crest, Flute type B/C
3. **Creasing Wheel Ø 60 mm:** 2x1.5mm 6pt (2 mm) round crest, Flute type A/B/Double
4. **Creasing Wheel Ø 60 mm:** V-Shape for double and triple flute board.

3.6 VERSATOOL (OPTIONAL)



NOTE! The purchase of a tool separately from the machine requires, only on first use, the execution of a reset procedure. See cap.6.4

The VersaTool accessory allows the use of instruments of the "i" series (interchangeable), allowing the operator to expand the range of tools available.



Figure 3-9

3.6.1 INTERCHANGEABLE CUTTING HEADS (OPTIONAL)



NOTE! The purchase of a tool separately from the machine requires, only on first use, the execution of a reset procedure. See cap.6.4

The VersaTool accessory, as mentioned above, can be equipped with a series of interchangeable cutting heads (optional), which allow you to increase the type of cuts, the type of passe-partout and the type of materials that can be processed, extending the range of processes available.



Figure 3-10

B - 45° Head (red) for bevel cut

The 45° head (red) cuts from the front of material with an inclination of exactly 45°. The head allows the cutting of all types of mountboard with thicknesses from 0 to 2,2 mm (0,087”).

C - 90° Head (grey) for straight cut.

Thanks to a wide Teflon foot it guarantees a wider cutting footprint and superior accuracy, especially on thick and hard materials (max 5mm – 3/16”). In combination with a vacuum table, it allows the machine to cut to the edge of the material.

D – 40° Head (green) for bevel cut

This head offers ample versatility guaranteeing an excellent quality of cut from the front of materials on all types of mountboard with thicknesses from 0 to 2,2 mm (0,087”). This head gives very good results when cutting curves with little radius and cuts good quality clip art.

E - Embossing head (purple) for pressing in relief.

The embossing head is designed for decorating in relief. Whatever design, corner or clip art it can be elegantly pressed in relief on a mountboard by using the pressure of a sphere.

F - 90° Head (white) for straight cut.

The 90 ° head (white) allows both a pass-through cut and a kiss-cut.

Depending on the blade holders and the kind of job the machine is supposed to perform the following blade might be available:

	Code	Description	Fields of use
	L100	Multipurpose Blade. 50° Angle	Universal knife for materials such as paper, cardboard, thin plastic, soft PVC, Foam Board.
	L100B	Multi-purpose Blade. 38 ° Angle for a more precise cut on small radius.	Universal knife for materials such as paper, cardboard, thin plastic.
	L1W40	Carbide multipurpose blade for a longer sharpening duration. 50 ° angle.	Long lasting blade ideal for very abrasive materials. (See L100)
	L1W46	Carbide multipurpose blade for a longer sharpening duration and with a 38 ° angle for greater precision on cuts with a reduced radius.	Long lasting blade ideal for very abrasive materials. (See L100B)
	002156	Multipurpose T16 Blade (38° Angle)	Universal knife for soft materials. To make sharp edges.
	002157	Multipurpose T17 Blade, with a tighter angle for greater precision on cuts with a small radius. (25° Angle)	Sole leather, cardboard, thin polyester. To make sharp edges.

Note: For any special need, other blades might be available. Please contact your local dealer, or the manufacturer for further information.

G - 45° Head (blue) for bevel cut.

The 45° head (blue) is offered for cutting from the backside of materials of all types of mountboard (matboard) and Foamboard with thicknesses of 0 to 5mm (3/16"). The use of this head is recommended for cutting all mountboards (matboards) that have a delicate face side that could be damaged by a classic front cut. It is also aimed for use with dense matboards with thicknesses of up to 4,4mm (0,173") like museum and conservation boards.

H – Fork The fork is the tool used to manually change the cutting heads and is always supplied with VersaTool.

3.6.2 SCORING / CREASING TOOLS (OPTIONAL)

The VersaTool accessory, as mentioned above, can be equipped with a creasing tool capable to perform creasing and perforating process on packaging materials. The head has the same fastening system as the interchangeable cutting heads and it is supplied with 9 creasers. The system provides for release and quick coupling of each tool making it very versatile.

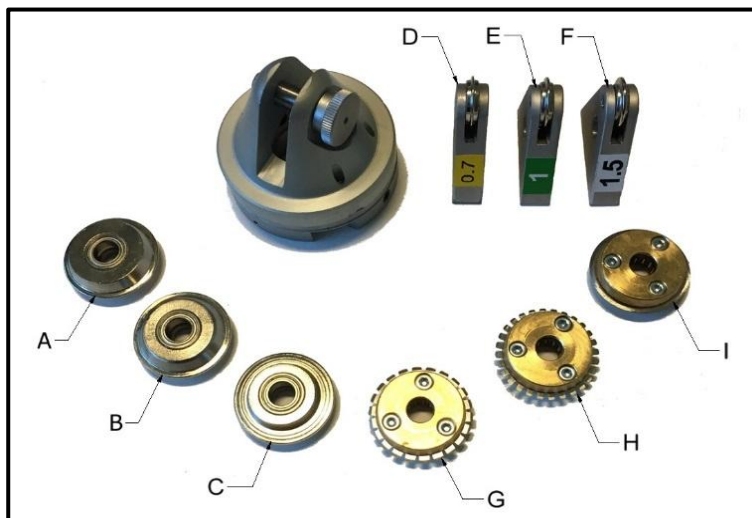

Figure 3-11

The set of tools for creasing consists of 9 tools each with different characteristics:

A - Scoring tool: 32mm / 1.26" diameter, 1mm / 0.039" round crest, tool for creasing corrugated cardboard

B - Scoring tool: 32mm / 1.26" diameter, 1,5mm / 0.059" round crest, flat board & E flute creasing wheel.

C - Scoring tool: 32mm / 1.26" diameter, 2mm / 0.078" round crest, flat board & E flute creasing wheel.

D - Scoring tool: 16mm / 0.63" diameter, 0.7mm / 0.0275" round crest, flat board & E flute creasing wheel.

E - Scoring tool: 16mm / 0.63" diameter, 1mm / 0.039" round crest, flat board & E flute creasing wheel.

F - Scoring tool: 16mm / 0.63" diameter, 1.5mm / 0.059" round crest, flat board & E flute creasing wheel.

G - Perforated tool: Serrated cut wheel, Ø 32mm / 1.26", 3-1mm / 0.118-0.039" step.

H - Perforating tool: Serrated cut wheel, Ø 32mm / 1.26", 2-1mm / 0.078-0.039" step.

I - Blade tool: Metal wheel, 32mm / 1.26" diameter, for scoring polypropylene 250 ÷ 500gr.

3.7 ROUTER (OPTIONAL)

The Router with the help of an industrial vacuum cleaner (not supplied with the machine as described at Paragraph 3.9) allows milling operations to be carried out, up to a max material depth of 13 mm (0.512”).

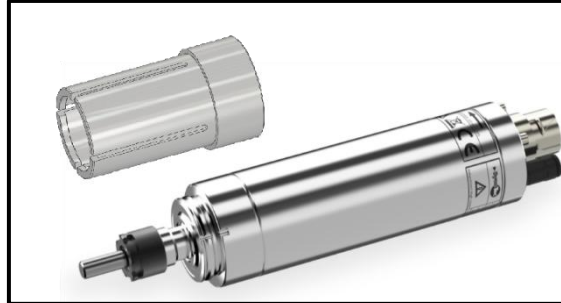

Figure 3-12

Depending on the work to be performed, the following cutters are available:

Code	Description	Materials	Ø	Rotation Speed
003040	S1-3.0/6 6-50 MP	Multipurpose: aluminium, ACM, brass, plastic, MDF etc.	3	24.000 rpm
003041	S1-4.0/6 14-50 MP		4	
002434	S1-5.0/6 16-50 MP		5	
003043	S1-3.0/6 6-50 A	Acrylic, plastic, foam, wood	3	
003044	S1-4.0/6 12-50 A		4	
002433	S1-5.0/6 16-50 A		5	

Note: For any special need, other cutters might be available. Please contact your local dealer, or the manufacturer for further information.



DANGER: The tool is normally cooled by an air circuit; however, after a long use, it could reach temperatures sufficient to cause burns if extracted immediately after the end of the workings from the head. Please use always protective gloves to avoid burns when extracting the cutter tool.

3.7.1 ALLOWED CUTTING TOOLS

The cutters used in combination with the Router must have the following characteristics:

- Must be suited for high-speed processing.
- Pay attention to the rules and maximum rotation speed specified by the tool manufacturer.
- The tools used must be balanced to G2.5 according to DIN ISO 1940-1.
- The length of the entire cutter must be 50 mm and protrude 17mm (0.67") from the collet. See par. 5.13
- The cutter shank diameter must be $\varnothing 6$ mm in diameter h7

3.8 MATSTYLUS DELUXE SYSTEM DESCRIPTION (OPTIONAL)

The MatStylus Deluxe is a tool for writing, decorating and drawing. This tool is supplied with adaptors, consisting of two interchangeable elements of different dimensions capable of holding different pens or pencils. Upon request a holder for plotter pens can also be supplied.

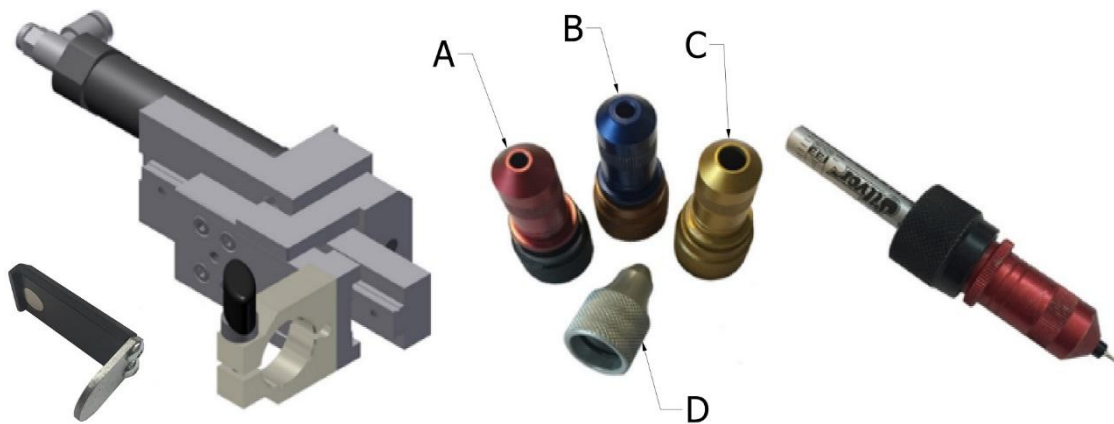

Figure 3-13

MatStylus Deluxe (optional) provides for three different sizes of pen cartridge and their caps to prevent them from drying out or damaging the tips of pens or pencils.

A – Pen Holder small

B – Pen Holder medium

C – Pen Holder big

D – Cap

3.9 TECHNICAL DATA

MODEL	V1225	V1612	V1620	V1630
Max working area	1200 X 2500 mm (47.24" x 98.4")	1600 X 1230 mm (63" x 48.4")	1600x2030 (63"x79.92")	1600x3030 (63"x119.3")
Cutting Capacity	5 mm (0.197") with tangential tool			
	20 mm (0.787") with oscillating tool Optional			
Max Speed	1000 mm/sec (39.3"/sec)			
Max Acceleration	2 m/s ² (78,74"/sec ²)			
Air Requirements	7 Bar/101 PSI – 3.50 CFM			
	8 Bar/116 PSI – 5.30 CFM (with oscillating tool)			
Rated power supply	3P+G 400V 50Hz 7.8KVA 60Hz 9KVA	3P+G 400V 50Hz 4.8KVA 60Hz 5.4KVA	3P+G 400V 50Hz 7.8KVA 60Hz 9KVA	
Machine weight	847Kg (1867 lbs)	630Kg (1389 lbs)	796Kg (1755 lbs)	TBD Kg (TBD lbs)
Sound emission	75dB			
Connectivity	Ethernet/USB			
DATA Buffer	External PC			
File Formats	.SVG; .PLT; .DXF; .CF2; .HPGL; .XML; .PDF;			
Tool Change	Manual			
No. Tools Holder	2 Holders			
Materials Holding System	Mechanical locking by pneumatic clamps and suction			
N° Vacuum Pumps	2	1	2	
Standard configuration	Cutting machine, with tangential tool			
Router Characteristics (optional)				
Maximum Milling Depth	13mm (0.512")			
Allowed indoors, room temperature	5 - 40°C (41 – 104 °F)			
Relative humidity	Max 80%			
Rated speed x1000 (rpm)	60			
Nominal tension	49V			
Maximum current	24A			
Maximum torque	27 Ncm			
Maximum power	900W			
Cutter Shank diameter	6mm (0.315") Note: 8mm (0.315 ") is allowed ONLY with special collet for MDF flat leveling cutter			
Industrial Vacuum cleaner (not supplied with the machine)	We recommend using an industrial vacuum cleaner with PowerFlex hose external Ø60mm, internal 50mm and suction capacity 300÷650m ³ / h			

3.10 INTENDED USE

The machine, depending on the tools is equipped with, can be used in the offset/digital printing sectors, or in the displays and packaging market, to cut various type of materials, see Table 1, with a maximum thickness of 5mm (0.19 ") (Thickness that grows up to 20 mm (0.78") using the oscillating tool), as well as milling processes on materials indicated in the Table 2, up to a maximum depth of 13mm (0.51").

Materials that can be processed with cutting tools:

Paper and Cardboard	Paper, folding cardboard, corrugated cardboard, honeycomb cardboard
Plastics	Forex, low density PVC, foams, rubber, polypropylene
Adhesive	Vinyl and plastic stickers,
Others	Fabrics, Leather, magnetic sheets

Table 1

Materials that can be processed with the router

Wood and its derivatives	wood, chipboard, mdf, multilayer, plywood
Plastics	pe, pp, pvc, ptfe, methacrylate, plexiglass.
Composites	aluminum, Alu-dibond resins

Table 2

Processing materials not mentioned in the previous tables must be authorized by the manufacturer after examining the technical data sheet of the material, taking in consideration the suction system as well.



CAUTION! To avoid damaging the cutting head, and the finished product, do not use material thicker than the tool can process



DANGER! The machine is not suitable for use in a combustible atmosphere.

The machine is designed for operation in laboratories.

During the installation, qualified person will be identified and trained, specifically the User and the Maintainer.

	Tasks	Characteristics
Installer	The installer manages the machine positioning, checks the electrical connections, and starts the machine.	The technician, or whoever is appointed and trained.
User	User manages machine operations and eventually it also provides for cleaning.	Figure chosen by the "customer" with the scope of identifying the person/s who will be responsible of using the machine. This figure will be properly trained by the technician.
Maintenance technician	The maintenance technician manages machine maintenance and repairs; therefore, it can also perform extraordinary activities with respect to those performed by the installer.	Figure chosen by the "customer" with specific technical knowledge able to be trained by the technician.

3.11 IMPROPER USE OF THE MACHINE

Integra is not suitable for any operation in a potentially explosive environment (ATEX).

The Integra cannot be used for processing materials other than those indicated in paragraph 3.9. In particular, materials such as:

- Glass fiber
- Carbon fiber
- Particularly flammable materials.

3.12 BEFORE USE

Before start using the machine, make sure is completely unlocked from any transportation security device, mounted on its feet, levelled and properly connected to a power source.

4 DETAILS OF THE COMMAND CONTROLS

All commands regarding the work cycle of the machine come from the computer.

The commands on the machine are:

- Emergency button (5)
- Machine Power ON (6)
- The vacuum pump ON/OFF selector (7)
- Vacuum pump alarm warning light (8)
- Vacuum ON/OFF selector (9)
- Manual Taps for vacuum zones 1,2,3,4 (only 1, 2 on Integra V1612)
- Clamp Pressure Gauge (10)
- Clamp Pressure Regulator (11)
- Vacuum switch display (12)

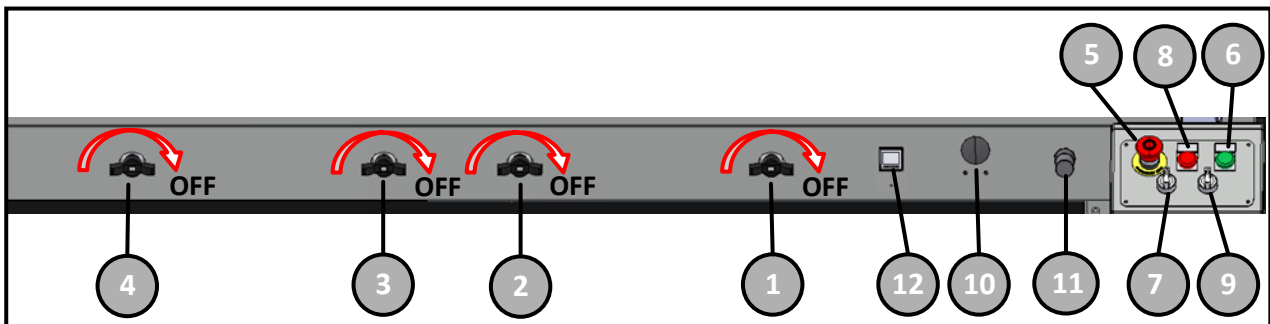

Figure 4-1

The EMERGENCY button should be used to stop the machine immediately if there is any danger to the operator or risk to the machine itself. It cuts power to all the axes cards. This button has a mechanical stop to prevent the operator accidentally pressing it again. To re-activate normal operations, turn the EMERGENCY button a quarter of turn in a clockwise direction to release the mechanical stop.

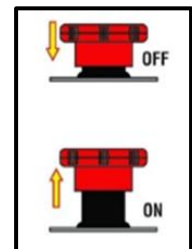

Figure 4-2

By pressing the Machine Power-On button (6), motors will be enabled and consequently engaged, as well as the clamps will raise up.

Turning the pump switches (7) CW, they start the vacuum pumps. Turning CCW they stop the pump engine.

Suction pump alarm indicator light (8): If light is on it indicates a malfunction in the power supply to the suction pumps.

By turning clockwise, the suction switch (9), suction will be activated on the different zone, according to the taps selection. By rotating counterclockwise, the suction will be released.

Manual Valve taps (1,2,3,4) allow you to enable/disable the suction on different areas (only 1, 2 on Integra V1612).

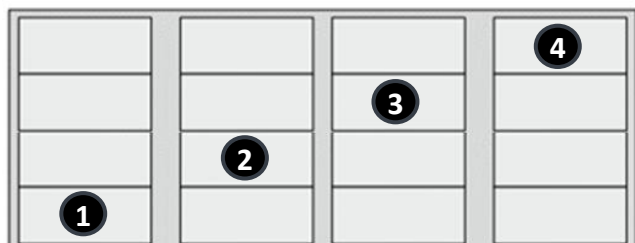

Note: On V1612 there are only taps (1, 2) and the table is divided into two suction areas only.

Figure 4-3

The pressure gauge (10) shows the pressure being used for clamping.

The pressure regulator (11) allows the clamping pressure to be adjusted so that it doesn't affect the surface of material being held for cutting.

The display (12) shows the vacuum value created on the material placed on the worktable. Below a certain safety threshold, the software will signal the risk of the material shifting during cutting/routing operations.

Note: During the use of all tools except the routing tool, if necessary, the displayed alert can be bypassed, and the work can continue.

5 PREPARING FOR USE

This paragraph is intended to list the important task to use the machine:

- Power the machine by turning the selector on the electrical panel of the machine clockwise **Error! Reference source not found.**
- Insert the power by pressing the Machine Power button (6), Figure 4-1

***Note:** If the button does not light up, check if the emergency button -Figure 4-1 - was pressed down, if so disarm it (see par.4) and repeat the pressure of the Machine Power key.*

- Turn the PC on and start the V-Studio program



CAUTION! In order to allow the connection between the PC and the machine, the machine should be switched on and connected to the computer before opening V-Studio.

- Make sure the MDF panel has been correctly placed on the working area.
- Place either the cardboard or the felt slip sheet on top of the MDF panel (See Parag.5.1).
- Remove the toll length protection (see parag. 5.2).
- Prepare the necessary tools (see the following paragraphs).
- Install the Tools into the relative slots (see the following paragraphs).
- Arrange the material to be processed on the work surface.
- Depending on the way you would like to clamp the material follow the below instructions:
 - **Vaccuum Table**
 - Start the vacuum pump using the selector (7) and open the suction using the selector (9) Figure 4-1.
 - Open vacuum zones (1) (2) (3) (4) according to the material dimension Figure 4-1.
 - **Pneumatic Clamps**
 - Rotate clockwise the movable part of each clamp (Figure 3-1) you would like to use, so that when the cutting cycle starts while descending they sill block the material.
- While using the router, turn the aspirator on.
- Load the file and once set-up the tools start the cutting process (See software manual)
- To interrupt a process, pause and restart it, simply press the appropriate keys on the PC (see software manual).
- In case of danger, it will be sufficient to press the emergency button to instantly stop and cut power off to the machine.

INTEGRA

To reset the machine:

- Disarm the emergency button (see paragraph 4)
- Press the Machine Power button (6), Figure 4-1
- Restore the program on the PC (see software manual).

5.1 POSITIONING THE PROTECTIVE POROUS WORKTABLE BOARD

To ensure a perfect cut it is essential that the blade slightly exceed the thickness of the material the operator needs to cut. To do this, it is essential to place a cardboard slip sheet or protective mat (1) on top of the MDF top.

- Connect the electrical and pneumatic systems.
- Release the emergency stop button and press Power On button to engage the machine.
- Open the V-Studio software so that the machine automatically raises the clamps.
- Place the cardboard slip sheet or the protective mat (1) supplied, under the clamps (2).

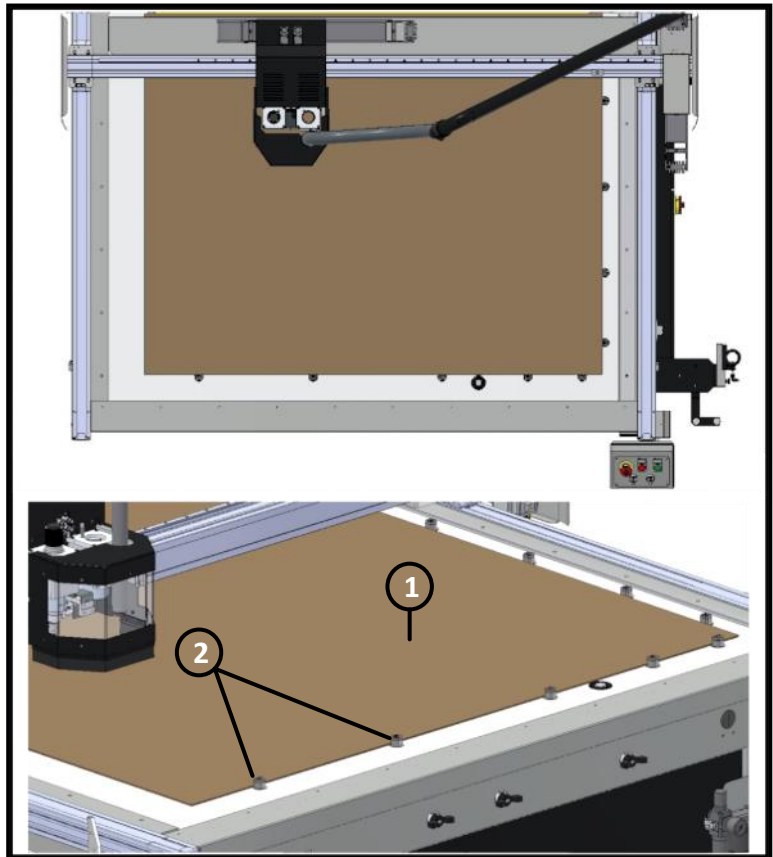

Figure 5-1

5.2 TOOL LENGTH SETTER



Warning: In case of use of the routing tool or any other tool that requires the tool length setter it is mandatory to remove its protection.

The tool length setter is the device with which the machine set the blades or the cutters length.

Whenever the router is used, the tool length is taken at any new cutting process. On the contrary the other tools only require once, generally during the tool setup procedure.

Remove the protection from the tool length setter, simply pulling it upwards

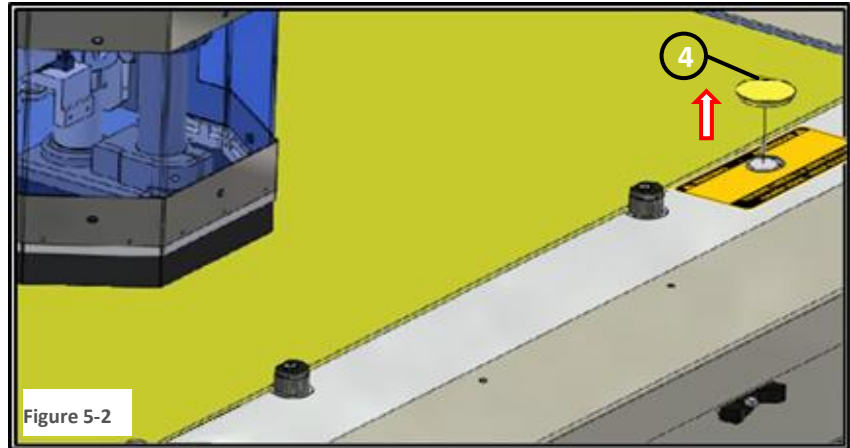

Figure 5-2

5.3 CONNECTING ROUTER SUCTION

Before using the router, the user must connect the machine with a dust extractor capable to the machine with a dust aspirator capable to remove and sore dust (See tech details at 3.8).

Integra, if sold with the router, is provided with a Powerflex type connection tube with a diameter of 50 mm.

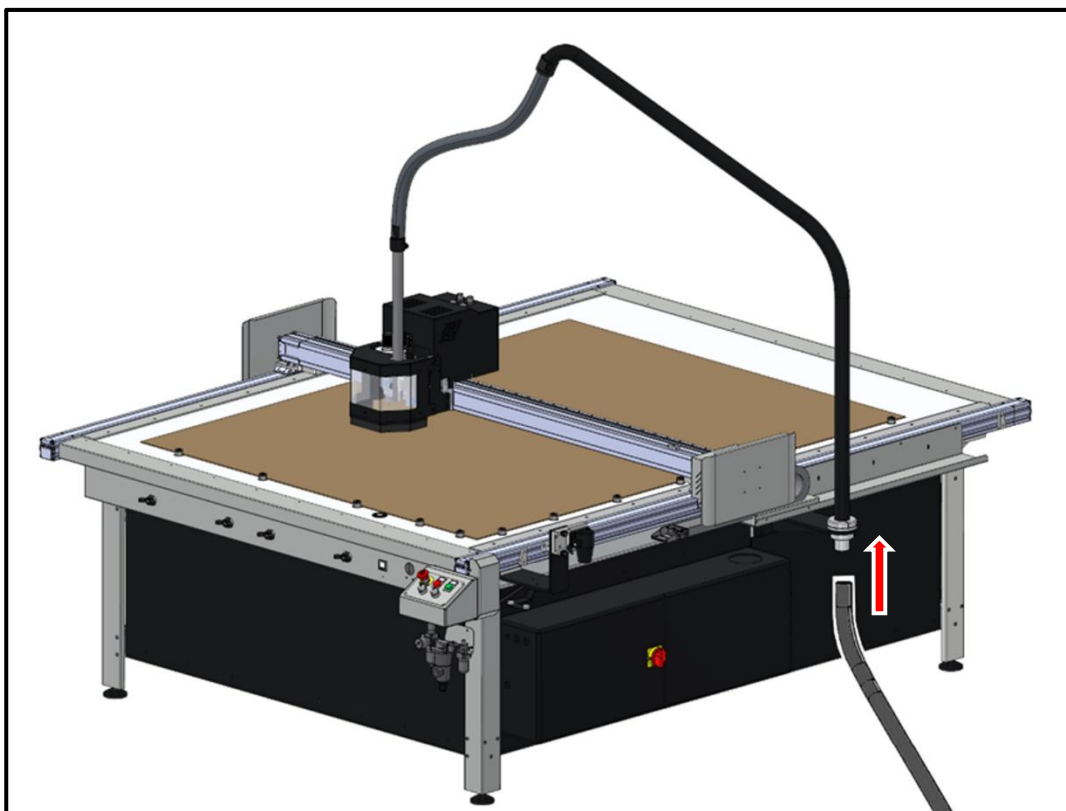

Figure 5-3

5.4 TANGENTIAL TOOL PREPARATION



DANGER: Use protective gloves is strongly recommended, be very careful as the pressure of the moving part (2) could cause the blade exit.

To mount or replace the blade holder, proceed as follows:

Note: Depending on the blades being used for the desired processes, the relative dedicated blade holder must be mounted (blade holder for L100 / L1W blades or blade holder for flat blades T16 / 17).

a) Loosen the locking set screws (1) and remove the movable blade guard (2) Figure 5-4.

Attention: If a blade is already mounted on the blade holder of tangential tool, first proceed removing the blade in order to reduce possible accidental injuries (carry out point (e) and then resume the procedure from point B).

b) Loosen the set screw (8) and extract the blade holder (9).

c) Insert the desired blade holder with the reference pin (10) oriented as shown in the figure and make sure that it is entered up to the stop.

d) Tighten the set screw (8).

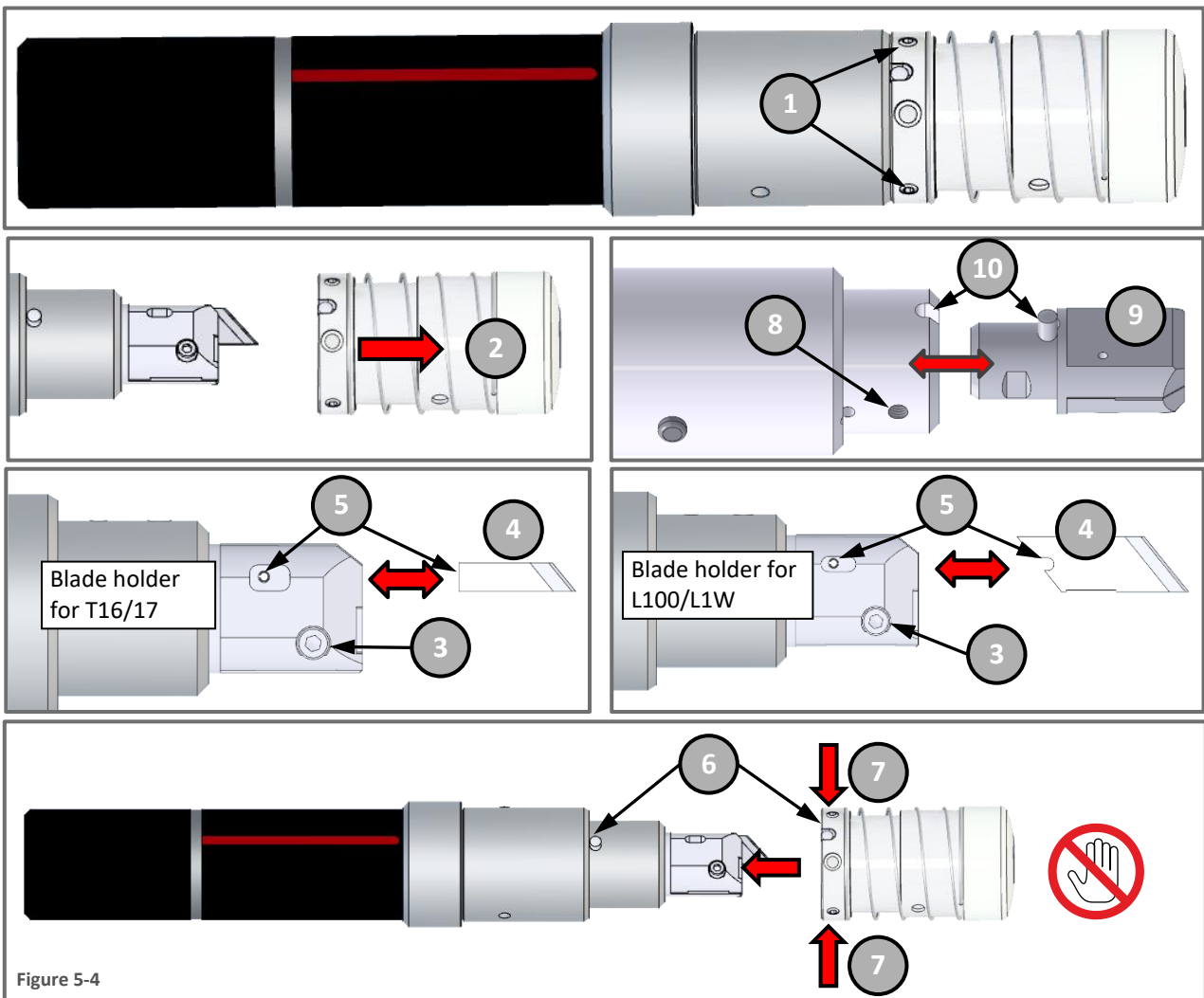

Figure 5-4

e) Loosen the blade cartridge screw (3) and remove the used blade (4) (if present).

f) insert a new blade (4) until the notch of blade reaches the pin (5), then tighten the screw (3).

g) Position the blade guard so that the reference pin matches its housing (6), then grab it from the sides (7) and push it towards the tool.

Attention: while inserting the blade protection, pay attention the palm of your hand is not positioned in front of the tool as indicated by the prohibition symbol.

h) Tighten the locking set screws (1).

To replace a blade, carry out the procedure described above, skipping points b) c) d).

5.5 OSCILLATING CUTTING TOOL PREPARATION (OPTIONAL)



DANGER: Use protective gloves is strongly recommended, be very careful as any pressure of the moving part (2) could cause the blade exit.

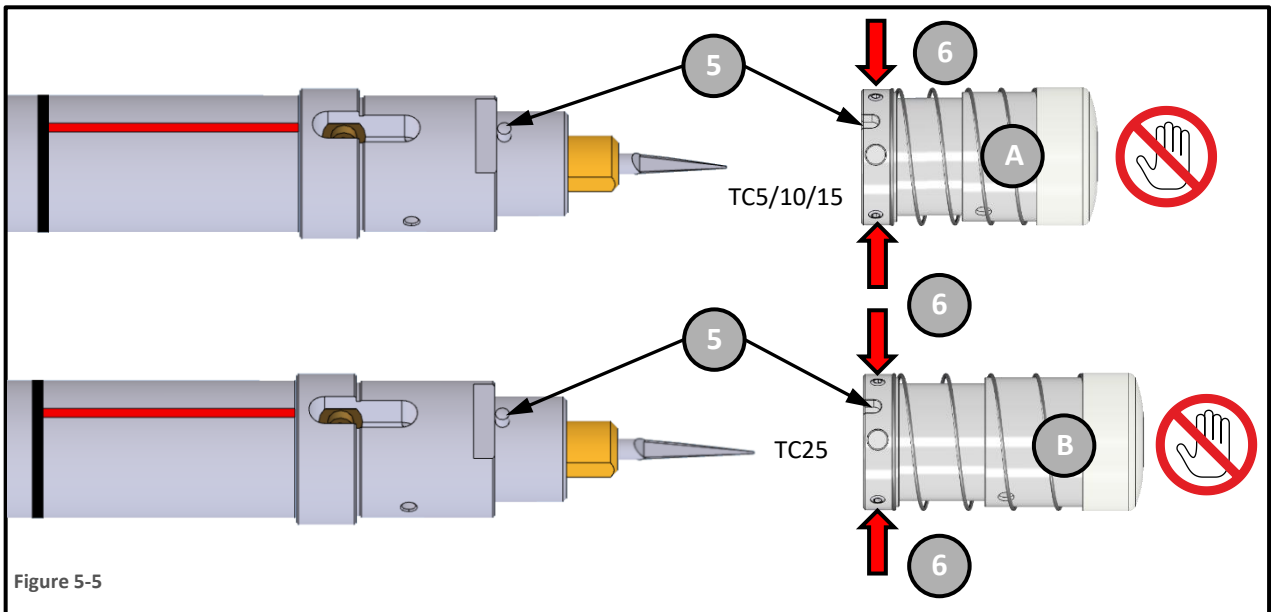
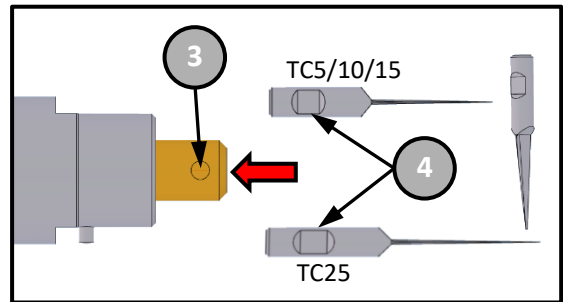
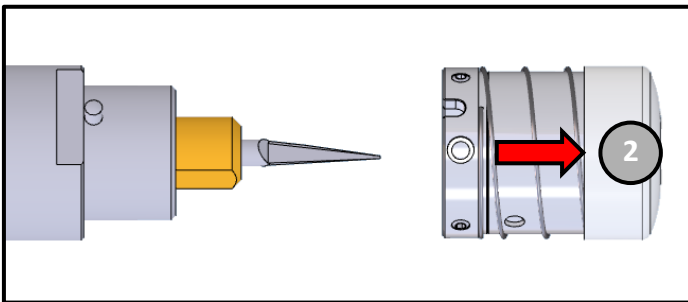
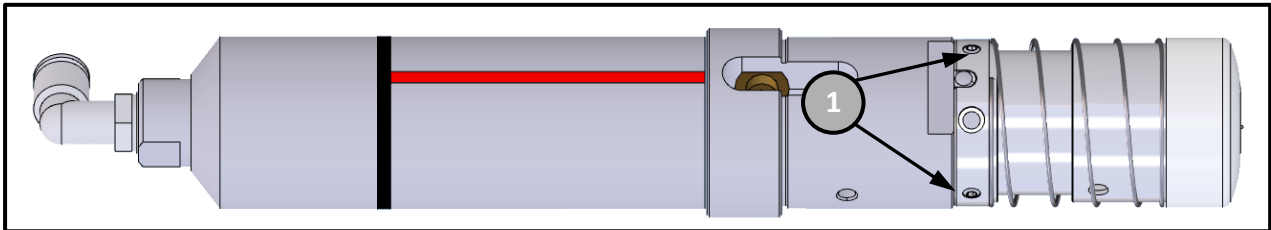

Figure 5-5

- Loosen the locking set screws (1) and remove the movable blade guard (2).
- Loosen the blade holder screw (3) and insert a new “TC” Type blade, paying attention that the blade notch (4) matches the locking screw and then push it inside until to the stop and tighten the screw (3).
- Position the blade guard (A) or (B), depending on whether we have chosen a TC5/10/15 or TC25 type, paying attention that the reference pin fits into its housing (5), then grab it from the sides (6) and push it towards the tool.

Attention: while inserting the blade protection, pay attention the palm of your hand is not positioned in front of the tool as indicated by the prohibition symbol.

- Tighten the locking set screws (1).

5.6 X TYPE OSCILLATING TOOL PREPARATION (OPTIONAL)



DANGER: Use protective gloves is strongly recommended, be very careful as any pressure on the moving part (2) could cause the blade exit.

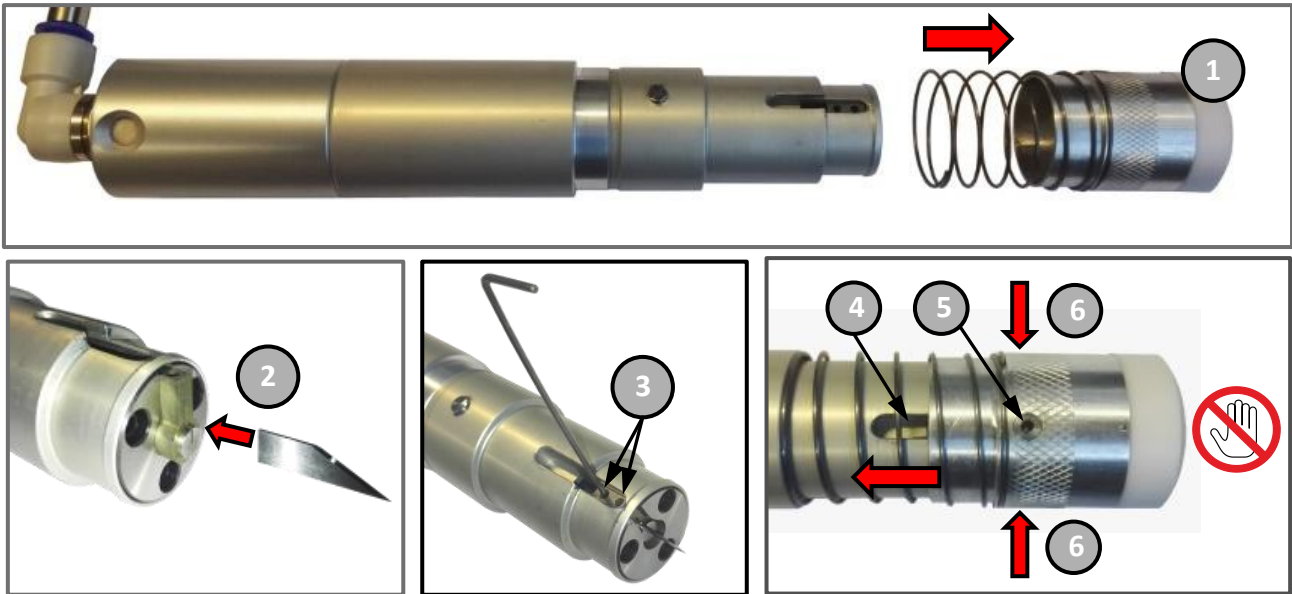

Figure 5-6

Remove the blade guard (1) by pulling it outwards.

- Insert a flat blade into its housing with the tip facing the centre of the tool (2).
- Tighten the two blade locking set screws (3) with a 1.5mm Allen key
- Position the blade guard so that the reference pin (4) matches the sliding slot (5), then grab it from the sides (6) and push it towards the tool.

Attention: while inserting the blade protection, pay attention the palm of your hand is not positioned in front of the tool as indicated by the prohibition symbol.

5.7 PREPARAZIONE UTENSILE KISS-CUT (OPTIONAL)



WARNING : Use protective gloves to prevent cuts.

Unscrew the blade shaft (counter-clockwise), then pull it out.

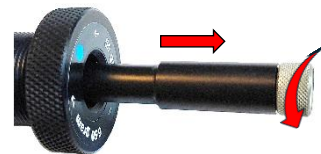

Insert the blade extractor onto the blade, then push on both side and pull the blade out of the seat.



Place a new blade paying attention to the correct side.

Insert the blade shaft back into the tool and screw it back in until the desired cutting blade depth is reached.



5.8 PREPARING THE T-MARK TOOL

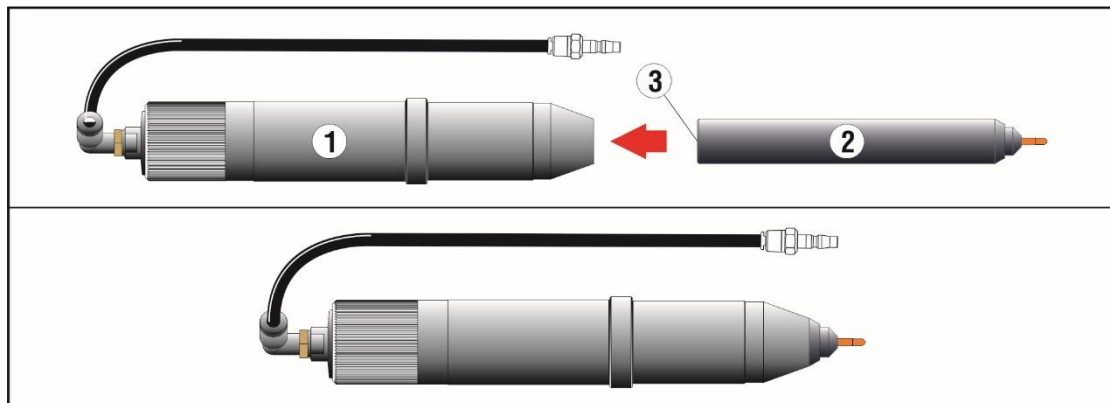

Figure 5-7

Insert the pen cartridge (2) into the penholder (1), as shown in the diagram above, until the magnet (3) holds the cartridge.

5.9 PREPARING THE CREASING TOOL

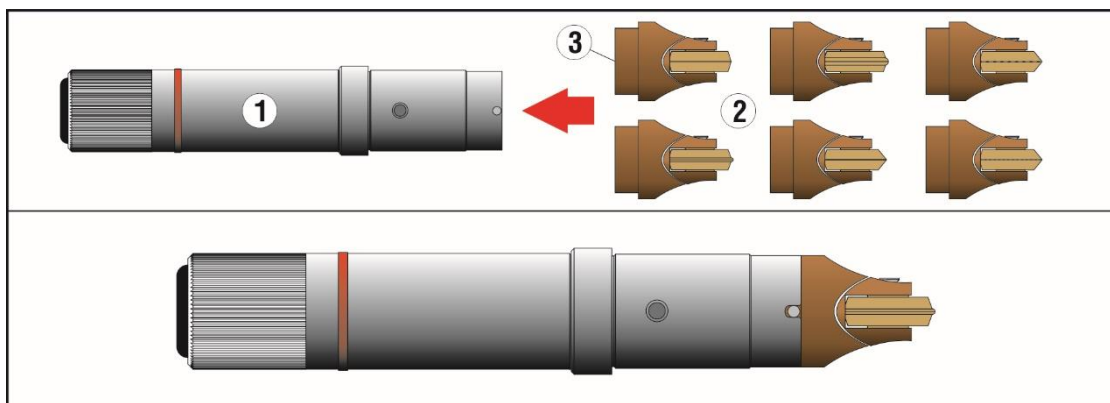

Figure 5-8

Insert one of the nine creasing wheels available (2) as shown in the diagram above until the magnet (3) at the base of the tool holds to the creaser.

5.10 FITTING A CUTTING BLADE VERSATOOL (OPTIONAL)



Warning! Handle the blade carefully, protect it if necessary, to avoid cutting. During reassembly use a rubber object to keep it in its housing during tightening of the locking screw.

- Disassemble the head (see chapter 5.18).
- Remove the blade holder (1) from the cutting head by loosening the set screw (2) with a 3 mm Allen wrench.
- Loosen the blade holder screw (3) with a 2.5 mm Allen wrench and insert the blade (4) until it reaches the pin (5), then tighten the screw (9).

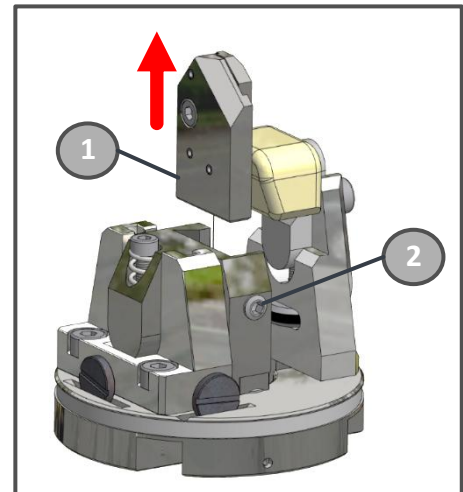
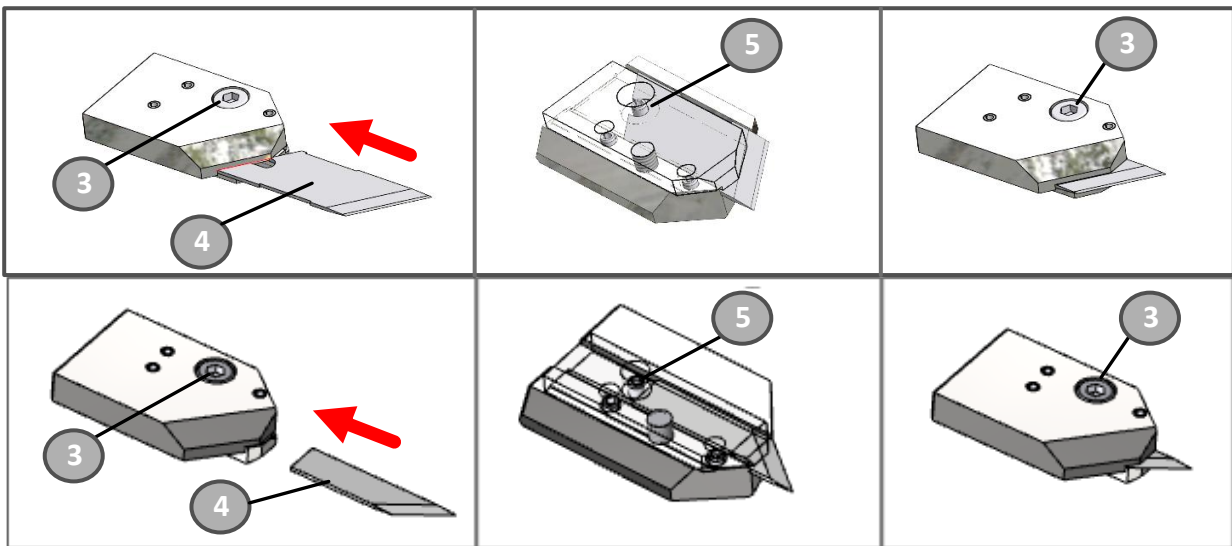

Figure 5-9



Insert the blade holder (1) into the cutting head and tighten the set screw (2).

Figure 5-10

- Reassemble the head (see chapter 5.17).

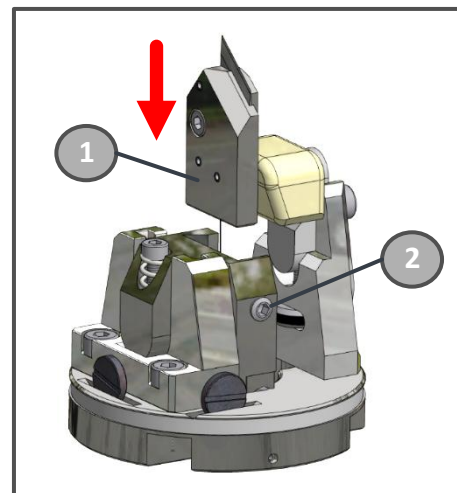

Figure 5-11

5.11 REPLACING THE FOOT/ROLLER ON WHITE HEAD - VERSATOOL (OPTIONAL)



Warning! Handle the blade carefully, protect it if necessary, to avoid cutting. During reassembly use a rubber object to keep it in its housing during tightening of the locking screw.

To replace the roller with the presser foot, and vice versa, proceed as follows:

- Disassemble the head ([see chapter 5.18](#)).
- Remove the blade holder ([see chapter 5.10](#)).
- Unscrew the screw (6) to remove the roller and the support (7).
- Screw the foot (8) with the screw (6).

Follow the same procedure to replace the foot with the roller.

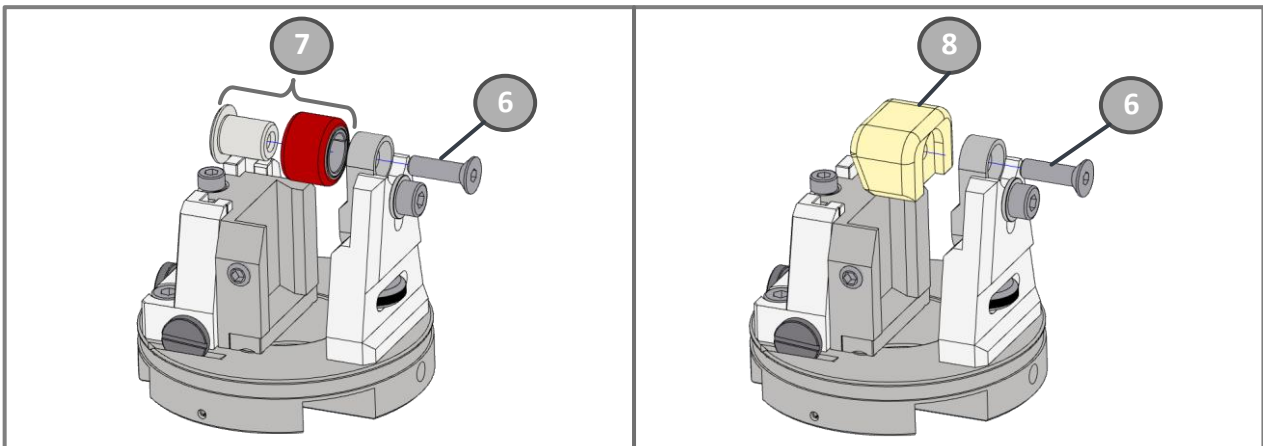

Figure 5-12

- Reposition the blade holder ([see chapter 5.10](#)).
- Reassemble the head ([see chapter 5.17](#)).

5.12 PREPARING THE ROUTER

To insert the cutter on the router please follow the below instructions:

- Hang the collet-chuck (3) into the clamping nut (1).

Figure 5-13

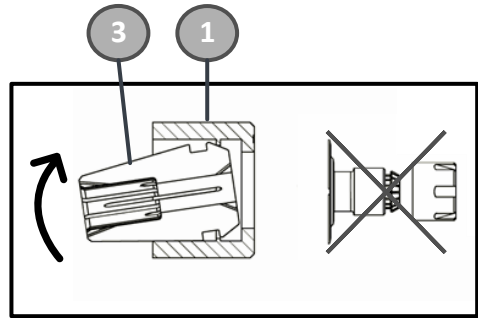

- Insert the cutter (4) into the collet-chuck (3) with clamping nut (1) (don't tighten).

Figure 5-14

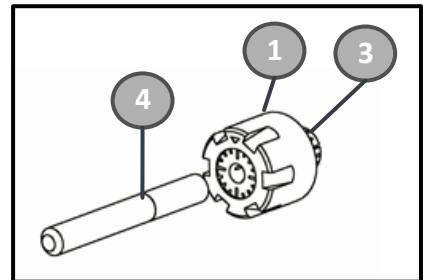

- Insert the spacer (5) on the tool body.

Figure 5-15

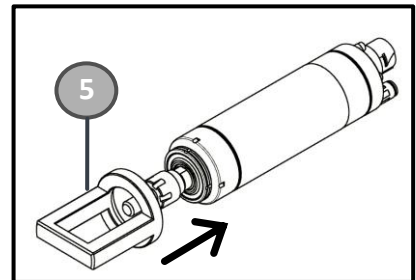

- Adjust the cutter so that it touches the bottom edge of the spacer as photo shows (4).

Figure 5-16

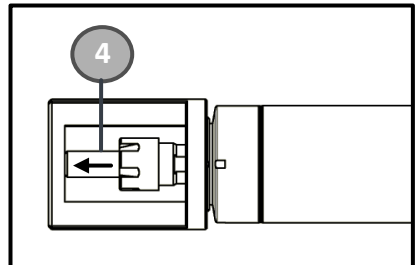

- Secure spindle shaft (2) with open-end wrench (6) and tighten the nut (1) with the clamping nut wrench in direction of the arrow → to secure the tool. (See Figure 5-26 for the tightening torque to apply.)

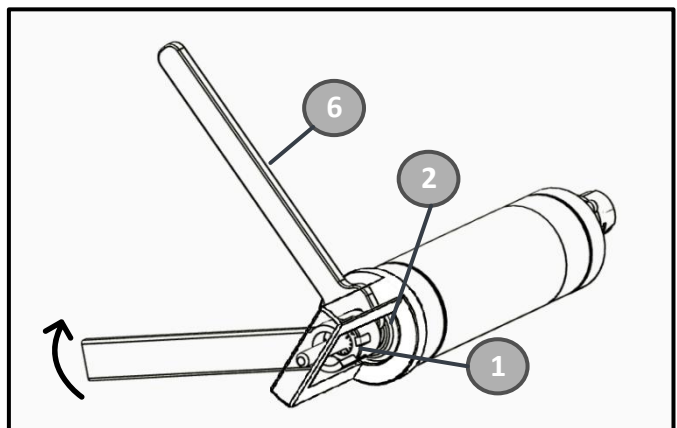

Figure 5-17



DO NOT tighten the collet without a tool inserted. This operation might generate permanent deformation.

- Remove the spacer..
- Insert the flange (6) on the tool body up to the stop (if not present).

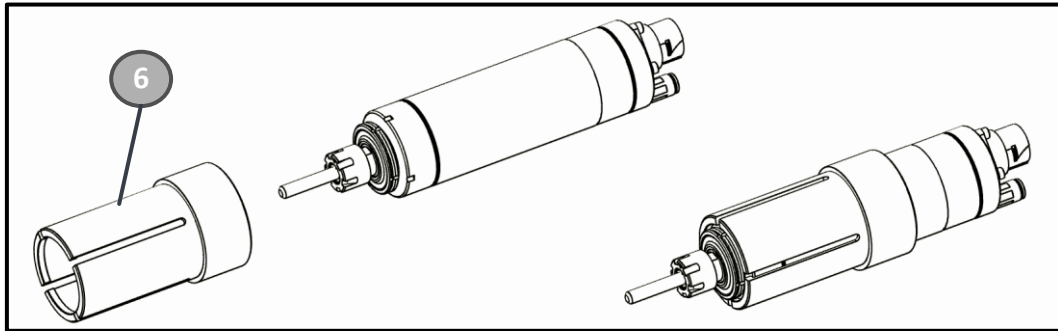

Figure 5-18

- Connect the plug into the tool paying attention to the position of the arrow that indicates the correct alignment.



The operation can be considered as terminated once the plug is firmly connected. (pay attention to the direction of rotation for both hooking and releasing).

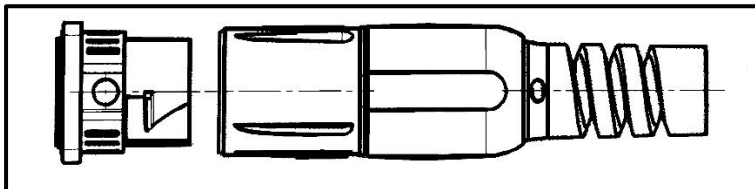

Figure 5-19



ATTENTION: During the entire working operation, the vacuum cleaner must remain on.



We recommend doing a daily warm up before first spindle start according to following daily warm up rules. After longer storage or standstill periods and before initial operation, start up the motor spindle according to the following run-in rules (greasing cycle the spindle bearing). During the run-in, the motor spindle temperature on the outside housing should not exceed 40°C.

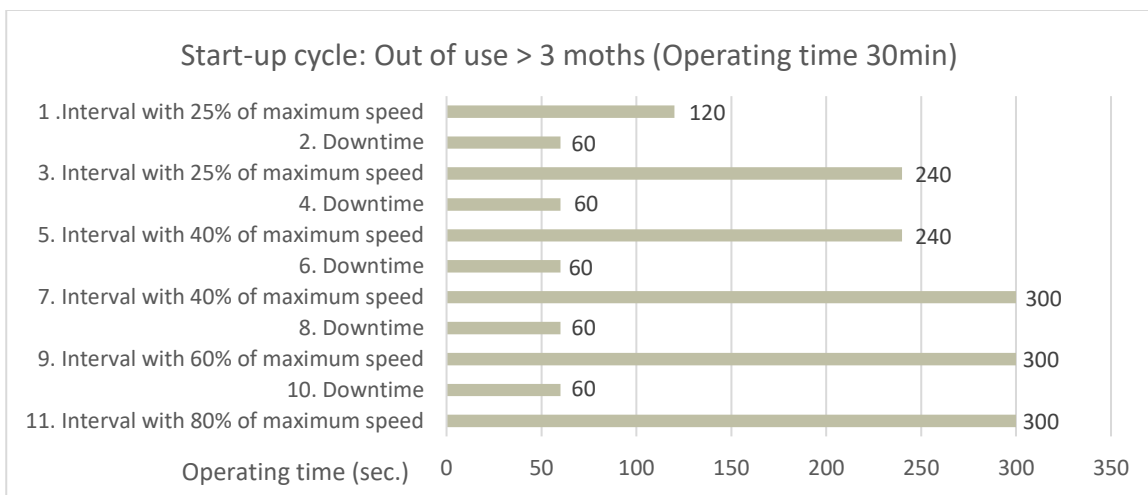
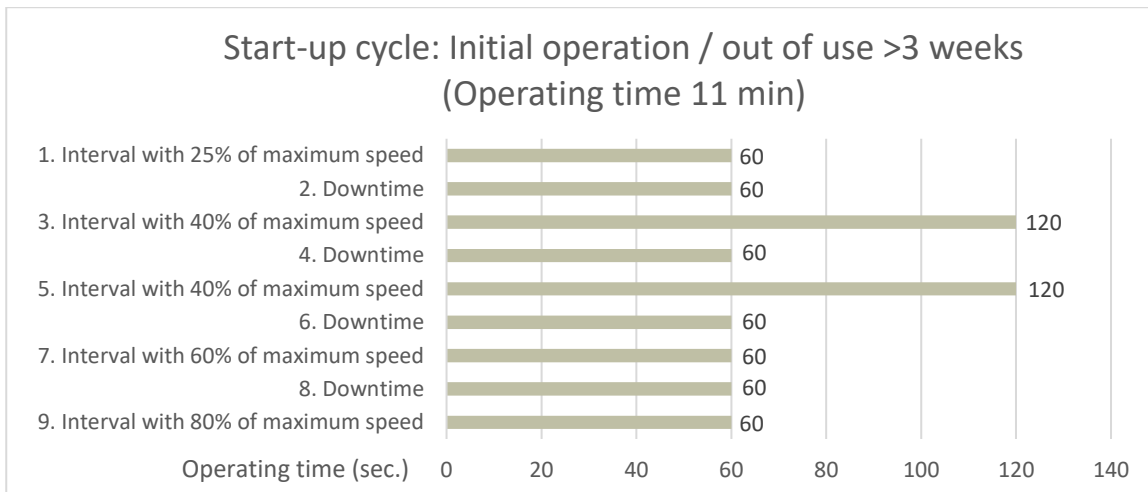
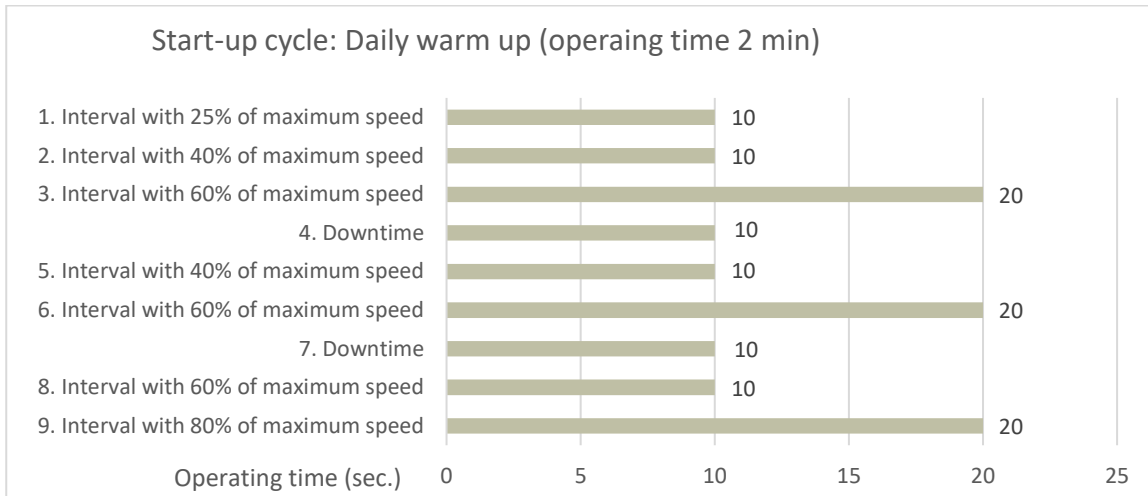

Figure 5-20

5.13 ROUTER USE ADVICES

Cutters positioning

The tool must be positioned correctly. A cutter that protrudes too much from the collet will produce vibrations and reduce its life over time. The quality of the cut will also be poor.

The use of the previously mentioned spacer will allow the tool protrude by the appropriate length. (Chapter 7.11)

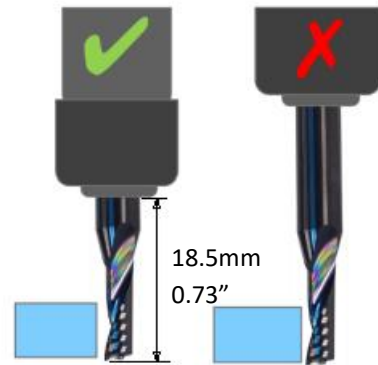

Figure 5-21

Cutting direction

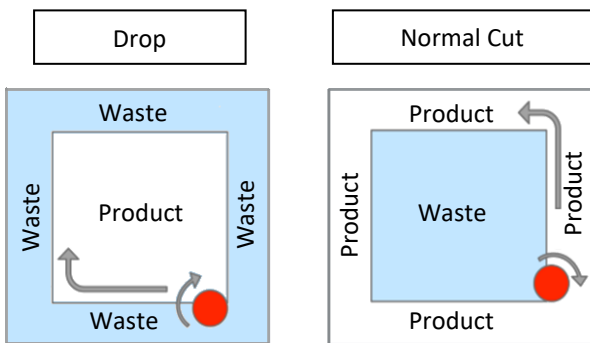

Figure 5-22

Cutter speed rotation

To obtain good results it will also be necessary to set the correct number of spindle revolutions in relation to the feed or the cutting speed.

Cutter Depth per pass

The cutter depth per pass should be adjusted according to the diameter of the tool and the feed rate used. This is also important if the vacuum pressure is not sufficient to hold the workpiece / material.

The correct cutter depth per pass depends on the size (diameter) of the tool and the capabilities of the machine.

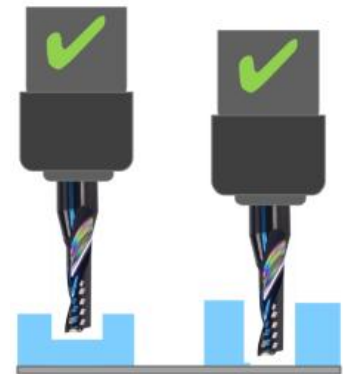
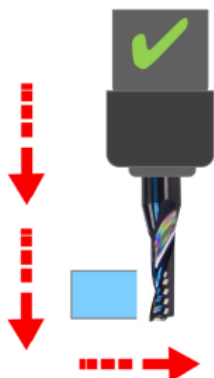

Figure 5-23

Feed Rate and Cutting Speed



The feed rate and cutting speed must be set according to the material, the cutter and the machine.

Figure 5-24

5.14 REPLACING CUTTERS



Danger: Replace or change the cutter **Only** when the machine is stopped and with the emergency button pressed down.

Secure the spindle shaft (2) with the open-end wrench (5) and loosen the clamping nut (1) with the clamping nut wrench in direction of the arrow →, until the tool can be removed forwards.

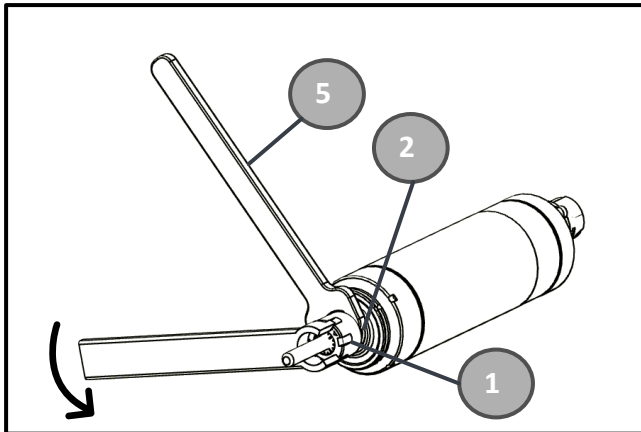

Figure 5-25

Insert the new tool in the collet-chuck (3) and follow above procedure described at Paragraph 7.11.

Tighten clamping nut (1) proceeding in the opposite way to what it was previously done.

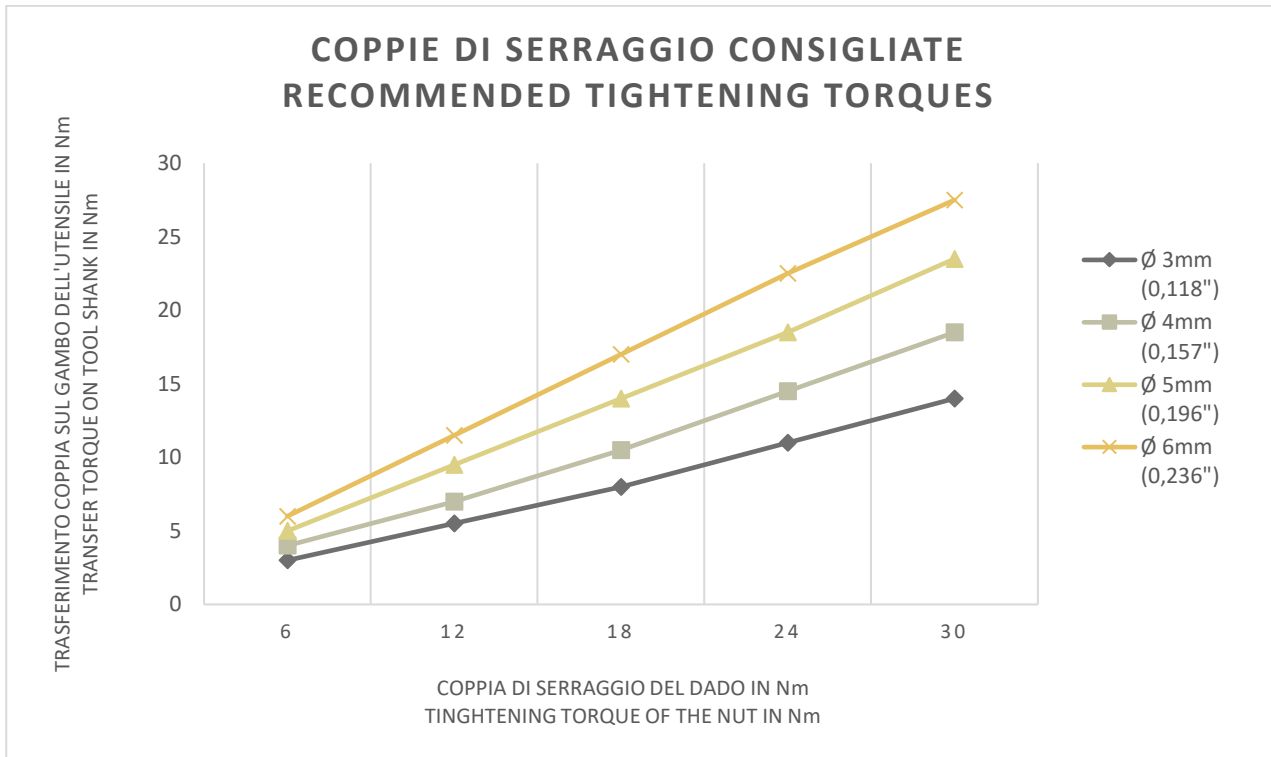

Figure 5-26

5.15 ASSEMBLING AND DISASSEMBLING MATSTYLUS DELUXE

To mount the Mat Stylus Deluxe device, proceed as per numbering.

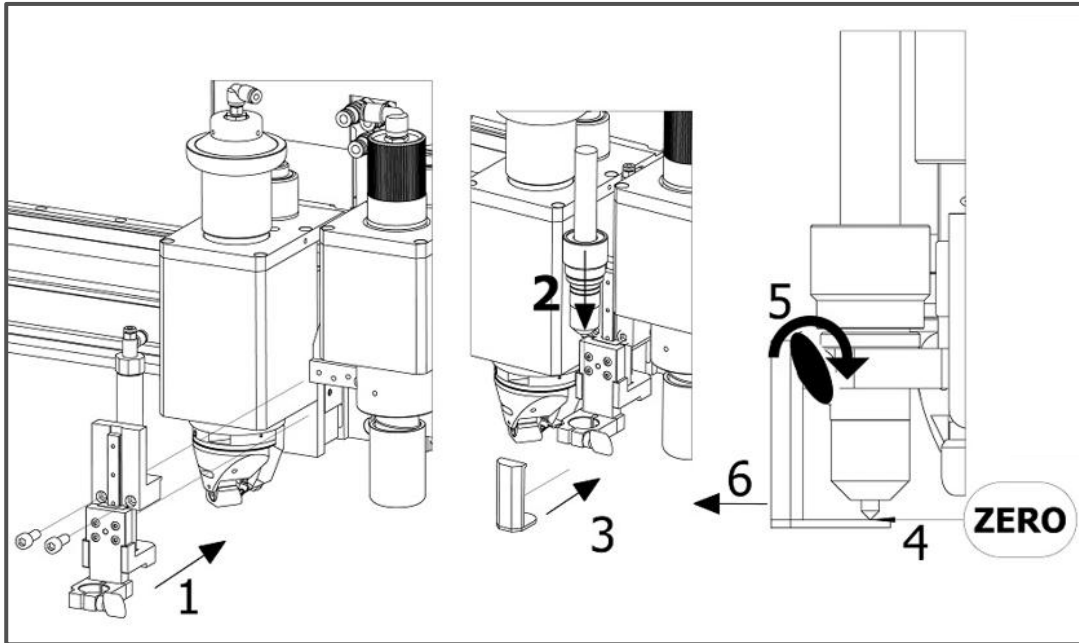

Figure 5-27

The detail (3) is fixed to the device by a magnet and is used to reset the pencil.

To remove it, perform the reverse procedure from step 7 directly to 1.

5.16 INSTALLING A TOOL

Whenever it is necessary to access the tool holders, it will be necessary to remove the safeguard protection. To remove the pre-mentioned protection, it will be enough to pull it away towards you.

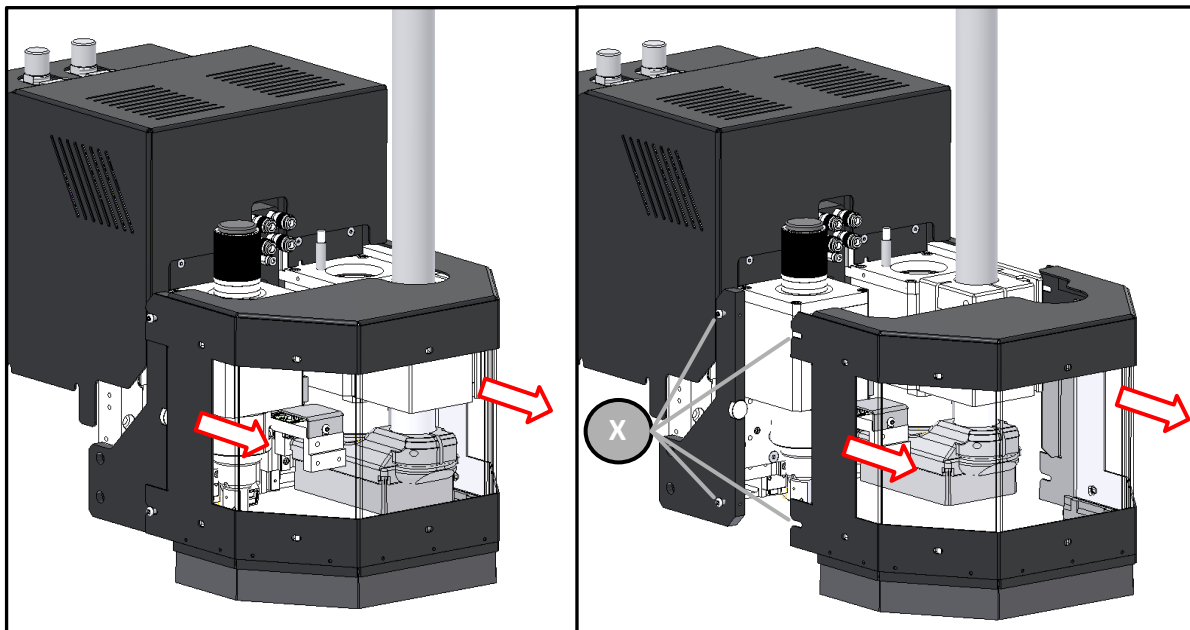

Figure 5-28

INTEGRA

Once removed, the protection can be hooked to its support, located on the right side of the machine.

The magnets, located on the holder, will ensure that protection is kept in position until the next use.

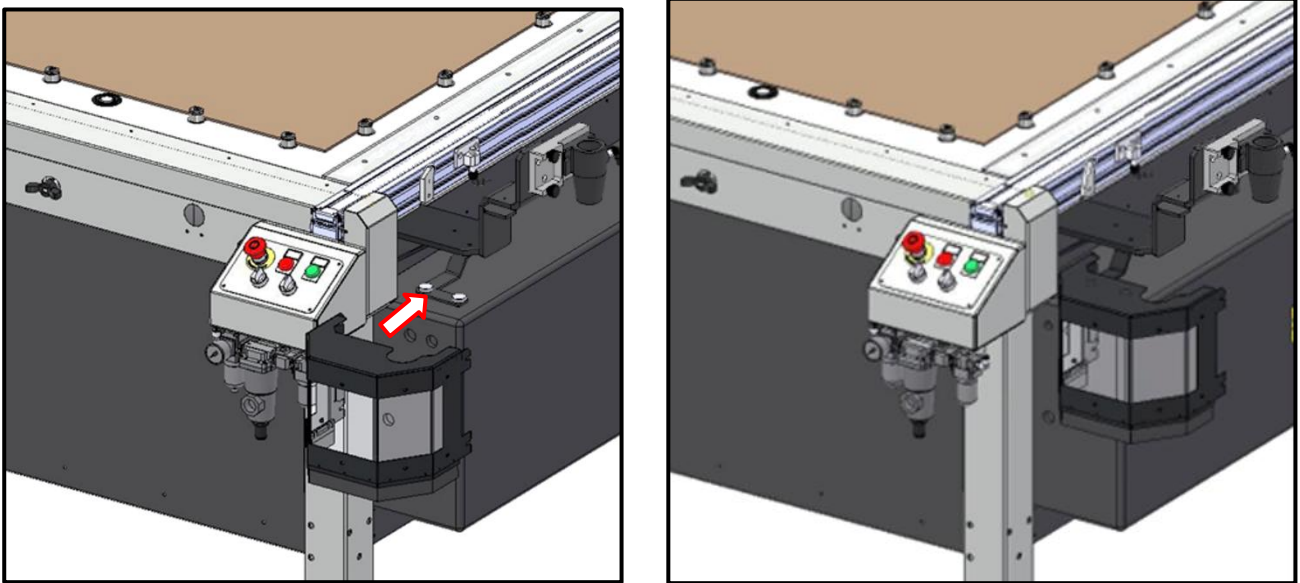

Figure 5-29



Attention: before running any job, always mount the safeguard protection on the machine. For correct alignment please make sure the side slots match with the reference screws (X) (Figure 5-28) and that the magnets have been engaged (DO NOT tighten the screws).

None all the tools can be fitted into any slot, **please read carefully** this paragraph for a correct tool assembling. The cutting tools (A-B) must be place only in head Nb.1, while the creasing (C), penholder (D), kiss-cut (H) and VersaTool (E) and the router (F) must be placed into the head nb.2. It is not possible to invert the tools.

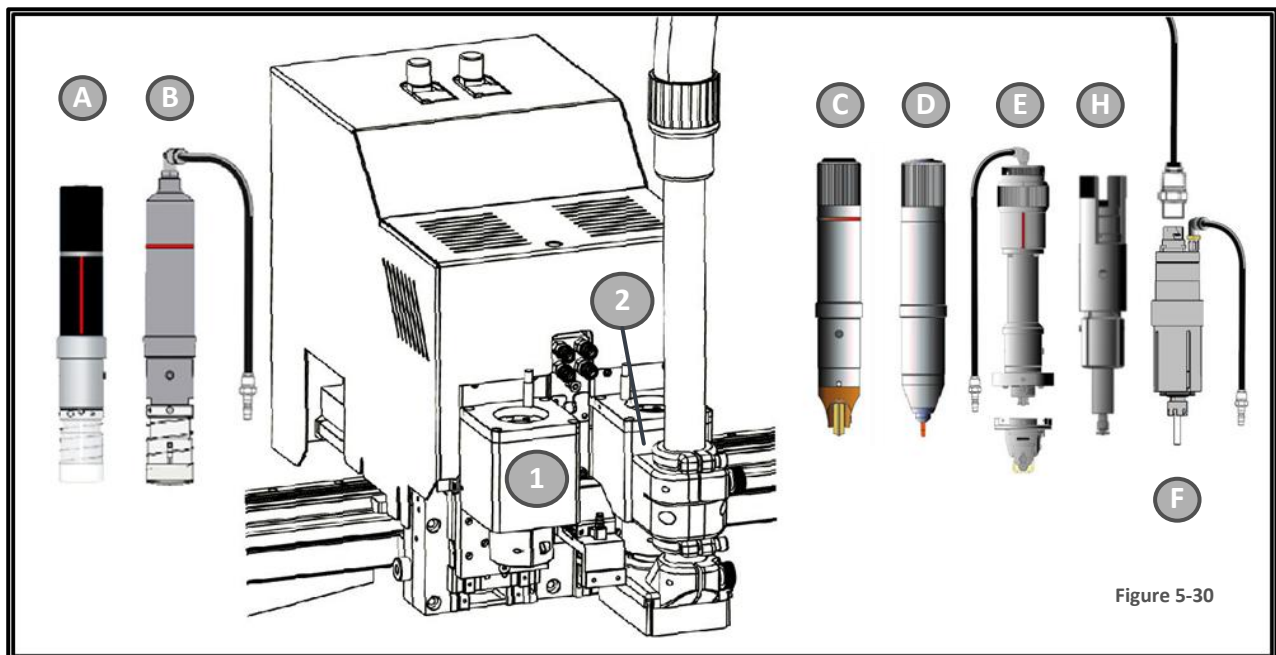

Figure 5-30

The Mat Stylus Deluxe (G) must be fixed with screws as described in paragraph .5.15

Use the screwdriver (N) supplied with the accessories to:

- Loosen socket head screw (L) to remove the tool and allow the installing of the tangential or oscillating tool.
- Loosen socket head screw (M) to remove the tool and allow the installing of the creasing, T-Mark tool, VersaTool or Router.

Note: The use or not of the router involves the assembly and disassembly of the suction from head 2, see paragraph 5.19.

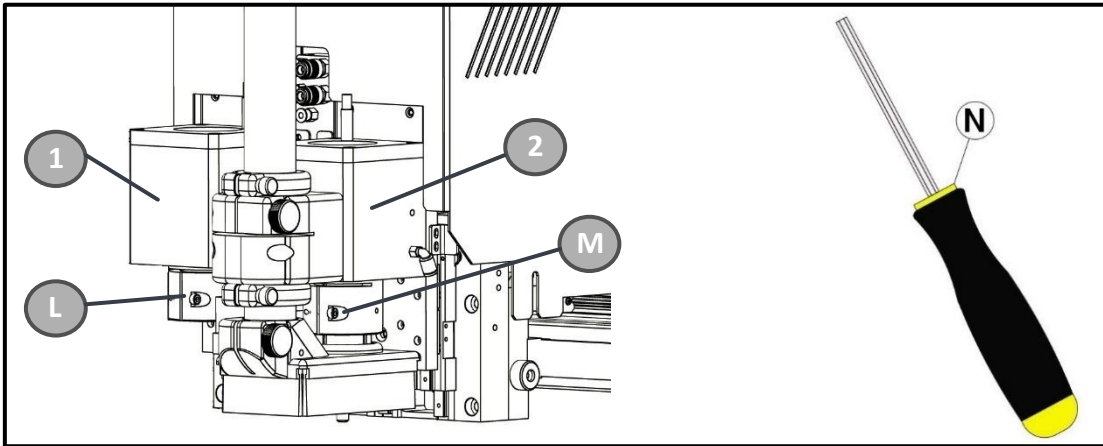

Figure 5-31

Attention: to use the VersaTool it is necessary to first loosen the screw (X) and extract the magnet support (Y).

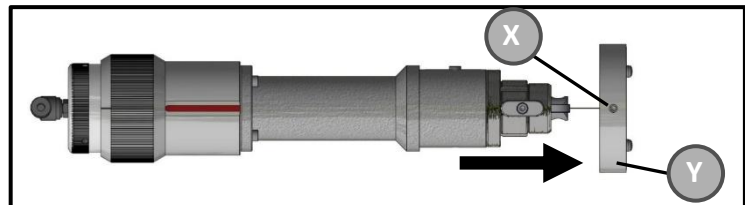

Figure 5-32

Once the screws are loosened insert tools in the appropriate slots (1 or 2) making sure it has reached the correct position, as shown in the diagram below.



Note: The pin "Y1" must coincide with the slot "Y2" (except the penholder and the Router).

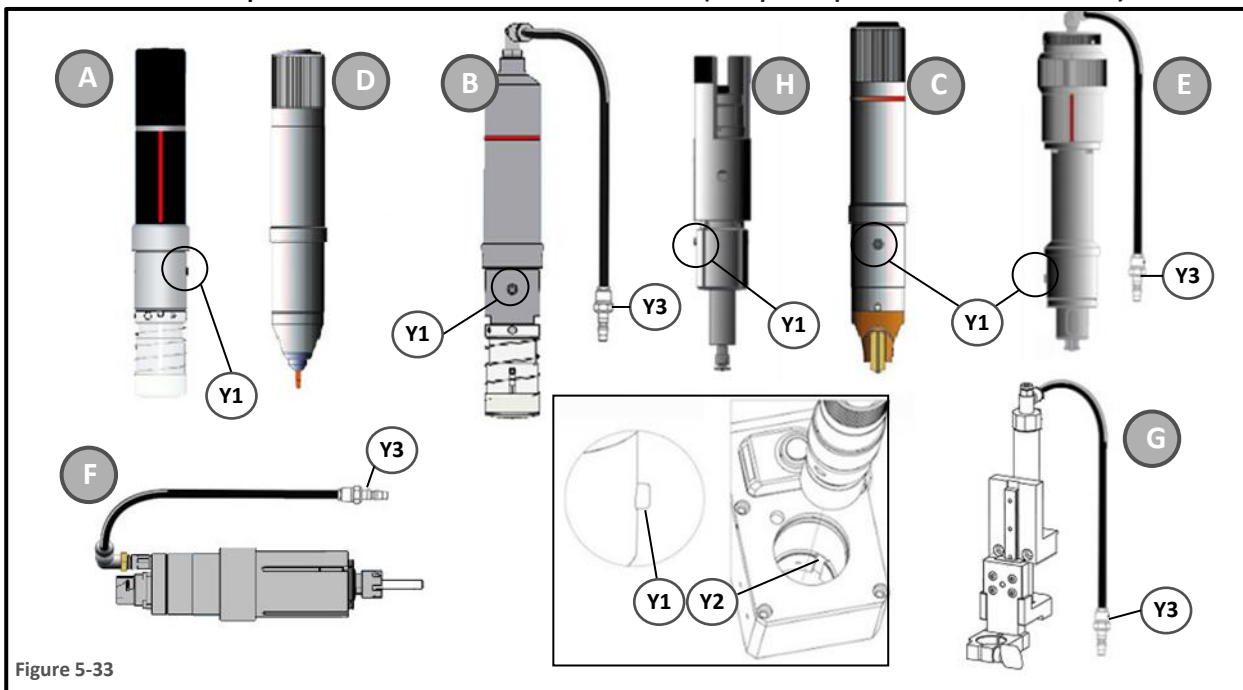

Figure 5-33

Once inserted, tighten the previously mentioned socket head screws (L and M) (Figure 5-31)

Some of the tools require to be fed with air compressed, please make sure to plug the quick male air connectors (Y3) for each tool (Figure 5-33) following the table.

Reference Figure 5-33	Tool Description	Reference Figure 5-34
A	Tangential Cutting	///
B	Oscillating Cutting	1
C	Creasing	///
D	Pen Plotting	///
E	VersaTool	2
F	Router	3
G	Mat Stylus Deluxe	5
H	Kiss-cut	///

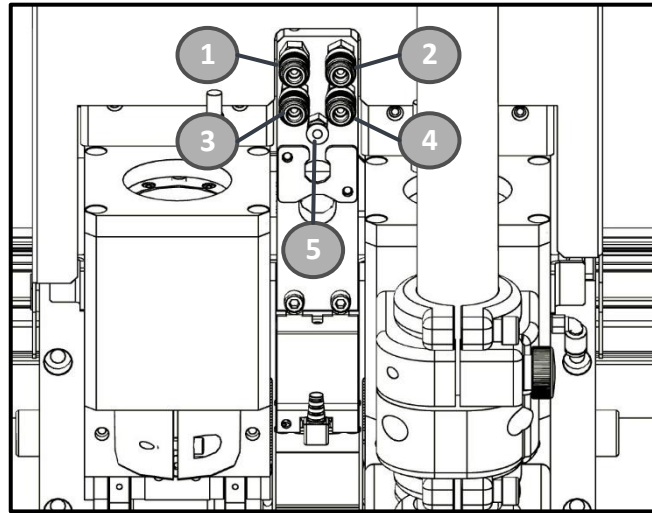

Figure 5-34

Attention: The VersaTool requires to have the magnets flange (Y) mounted as well to be fully operating. The same flange will host and hold the interchangeable cutting heads. An addition set screw (X) will allow to tighten the head.

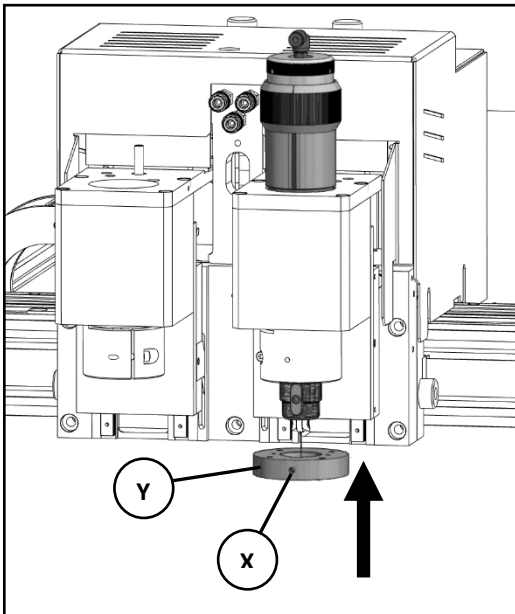

Figure 5-35

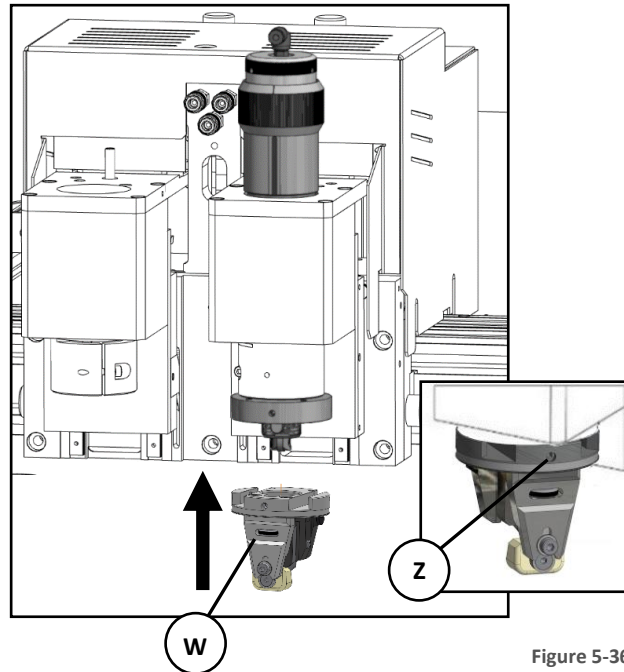

Figure 5-36

5.17 ASSEMBLING THE VERSATOOL HOLDER

To mount any head (W) on the VersaTool, plug it on the magnets flange and when it adheres to the flange, tighten the screw (Z) (Figure 5-35).

5.18 DISASSEMBLING THE VERSATOOL HOLDER

Whenever you need to replace any head with another one, proceed as follows:

- Loosen the screw (Z) (Figure 5-35).
- Hold the release tool/fork (1) by its handle and insert it into the slots located in the top part of the head. Holding the tool with one hand and the release fork tool with the other, insert the fork teeth into the head slots (2) and give it a slight knock to release the head.
- This operation will detach the interchangeable head from the magnets flange, and the head will remain attached to the magnet of the fork (3)
- Pull away the tool.
- Fit the most suitable head for the next job (paragraphs [5.17](#)).

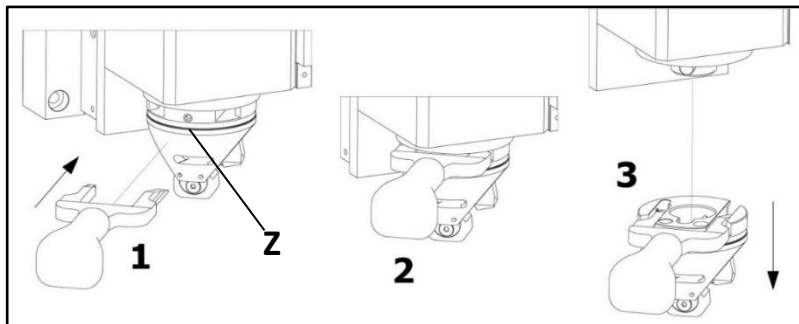

Figure 5-37

5.19 ASSEMBLING THE ROUTER AND SUCTION SYSTEM

The suction tube and the router are closely related each other as they are attached together, therefore whenever the router will be used the tube will follow it and it will require to be connected with its flange.

- Loosen the knob (1) that holds of the suction hood in position (2).
- Extract the suction flange (2) by pulling it downwards.

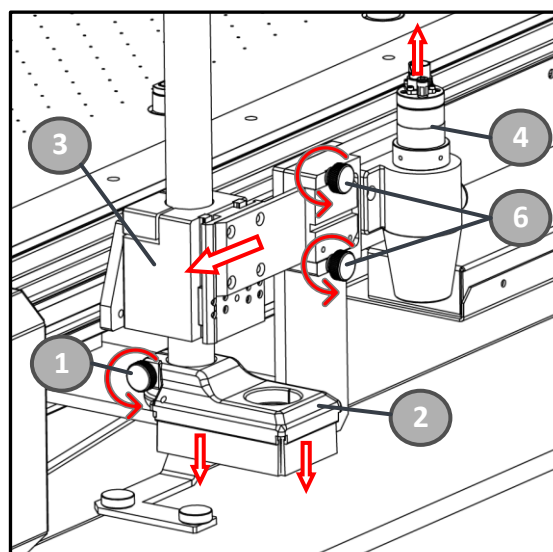

Figure 5-38

INTEGRA

- Loosen the knobs (6)
- Remove the suction support (3) and the router (4) from their housing and install them on the head 2.
- Insert the support (3) into the housing (5), paying attention that the key housing (8) matches with alignment key (7), then tighten the screws (9).
- Insert the suction hood (2) on the tube up to the stop so that the hole in the head where the cutter will be housed is centered on the hole in the hood.



Note: The cuff has a reference key that fits into the tube opening (X) and that holds it in the correct position. To make sure it has been assembled correctly, try to rotate the suction hood, if this won't happen it will confirm the operation has been made correctly. If not repeat the same operation pushing the hood upwards until it stops.

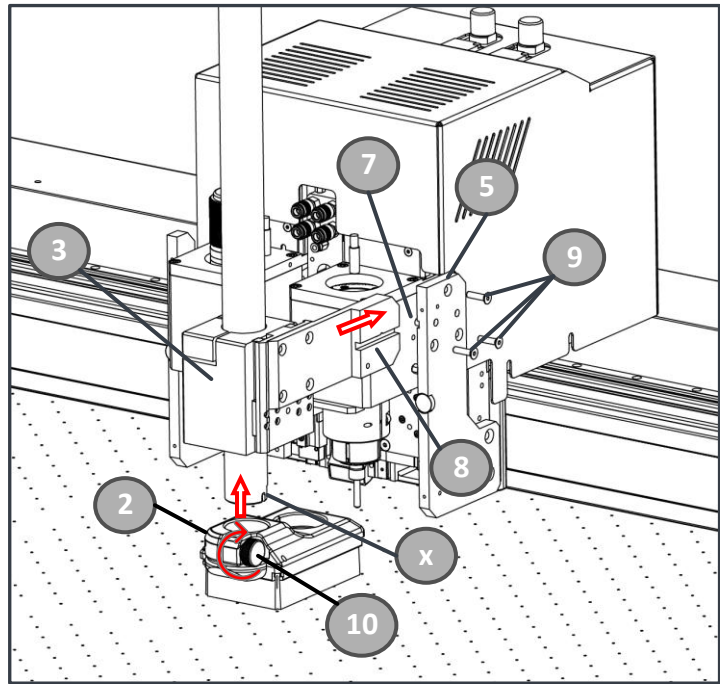

Figure 5-39

- Tighten the knob (10)
- Insert the router into the head slot, then fix it firmly and connect the air hose as described in par. 5.16

In the event that it is required to use a different tool in the head position 2 you will be asked to remove the router following the above-described operations in reverse.



Warning: Do not alter the position of the suction tube within its support, as this could lead to collisions between the various moving components. If it becomes necessary to adjust the height of the suction hood, loosen screw (12) and slide the tube in the desired direction, then tighten the screw.



Warning: The suction hood (2) must be positioned facing outward from the machine when not in use Figure 5-38 to avoid collisions with the moving parts of the machine.

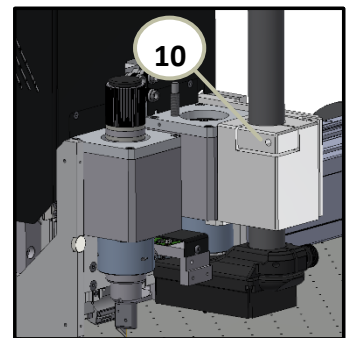

Figure 5-40



Attention: When the router is not used, it must stay in its housing since there's a sensor that advise when the tool is in the rest position. If not done, any other tool installed in the head 2 will not be piloted correctly, with the possibility of malfunctions or damage to the blade or the tool itself.

6 ADJUSTMENTS

To ensure perfect result it may be necessary to perform some manual adjustments, such as:



NOTE! The purchase of a tool separately from the machine requires, only on first use, the execution of a calibration procedure. See cap.6.4

6.1 ADJUSTING THE VERSATOOL CUTTING DEPTH

To adjust the VersaTool cutting depth is sufficient turn the knob (1) anticlockwise (to increase), or clockwise (to decrease) the cutting depth.



NOTE! One unit on the counter corresponds to 0,1 mm (1/32").
Ten units correspond to 1 mm (10/32")

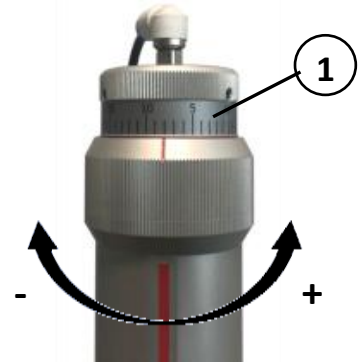

Figure 6-1

6.2 ADJUSTING THE CUTTING PRESSURE OF THE KISS-CUT TOOL

Once inserted the standard knife blade into the knife holder. Make sure the knife blade is firmly fixed in the holder. The knife is inserted correctly if it cannot be removed manually from the knife holder. The installation tool can be used to apply enough pressure on the knife to secure it.



Figure 6-2

Gently insert the knife holder into the tool shaft. Hold the nose piece in place with one hand and, with the other hand, turn the knife holder counterclockwise until the alignment pin fits into the small notch of the tool shaft. Now, turn the knife holder clockwise until its thread takes hold inside the tool shaft.

Choose the correct spring (3) based on the material thickness and consistency, so that the applied cutting pressure can be manually adjusted accurately for the specific material.



Figure 6-3

Hold the nose piece in place with one hand. Adjust the knife depth with the other hand by turning the knife holder clockwise until the knife tip is just visible from under the nose piece.

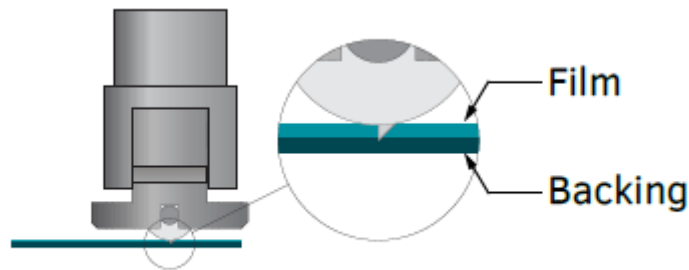

Figure 6-4

6.3 ADJUSTING THE DOWN PRESSURE OF THE CUTTING HEAD

To cut special hard materials, or to avoid the wheel of the cutting head leaves a mark on soft materials, it may be necessary to adjust the pressure of the air in the cylinder controlling the head down pressure. Adjustment can be made as follows:

- Pull knob (1) out (on) for a short distance to release the pressure regulator.
- Turn the knob (1) until it reaches the pressure necessary for the blade head to operate correctly.
- When the correct pressure is reached push the knob (1) home to lock in place (OFF).

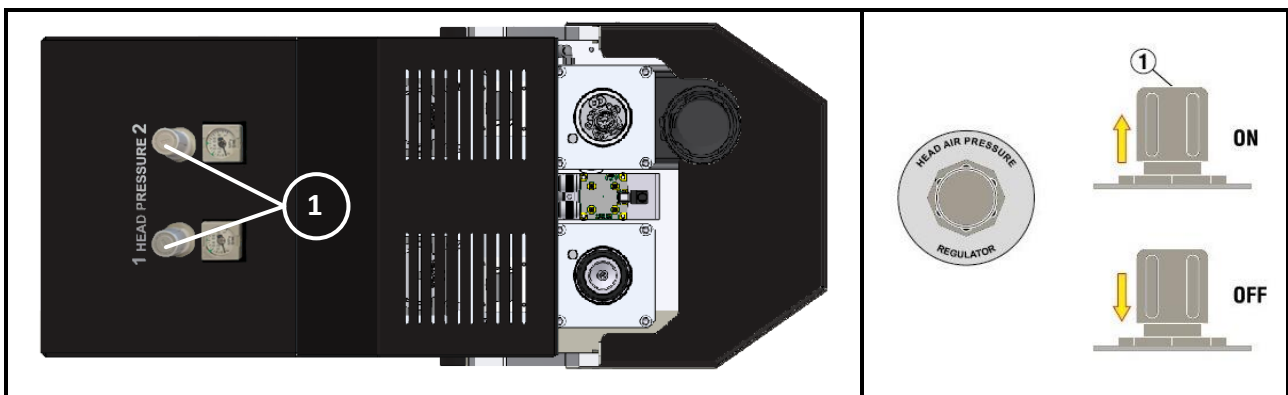

Figure 6-5



NOTE! When you finish a kiss-cut, turn the switch (K) to KISS-CUT OFF mode before performing any other processing to avoid damage to the worktable

6.4 TOOL RESETTING PROCEDURE

For tools purchased separately from the machine, it is necessary to carry out a reset procedure aimed at calibrating the tool height position.

The Router is the only tool that does not require this operation since the length of the tool will be checked at any job.



Attention: make sure that there is no protection on the tool length setter cap, see par.5.2.

6.4.1 RESETTING TOOL: 90° TANGENTIAL, CREASING, MARKER AND VERSATOOL

After having carried out the tools preparation and the assemble procedures (described in the previous paragraphs), you will be asked to perform the operations described below to reset the tool



Note! When performing this operation with the Tangential tool, the tool should have the blade cap removed. Figure 5-4.

- Assemble the tool with the blade and lock the set screw that hold the tool. Figure 5-31.
- Open V-Studio > Diagnostic and select the tab for tool calibration.

6.4.2 RESETTING THE OSCILLATING TOOL

To reset the Oscillating Tool A it is necessary to use the pad gauge provided with the tool and follow the below instructions:

- Remove the blade guard and the blade as per Paragraph 5.5
- Insert the plug gauge (1) up to the end.

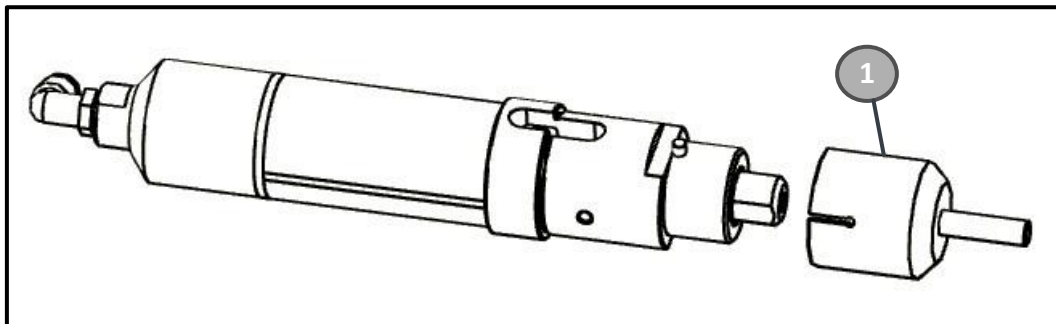

Figure 6-6

- Insert the tool into the head as per paragraph 5.16 (DO NOT connect the air hose).
- Tighten the locking screw Figure 5-31.
- On the PC open the V studio, then follow the instructions on the software manual.
- Once terminated the reset procedure remove the tool from the head and remove the “plug gauge” (1).

7 ROUTINE MAINTENANCE

Very little maintenance is required, and it is limited to the operations detailed in the following paragraphs.



CAUTION! Please disconnect the machine from electricity, before carrying out any maintenance operations.

7.1 LEVELLING MDF BED (ONLY WITH ROUTER VERSION)

Whenever you think there is not perfect planarity on the machine's bed, you may want to level the MDF bed using a special cutter.

To perform this operation, proceed as follows:

- Remove the slip sheet from above mentioned the MDF board.
- Before doing anything please check the condition of the MDF panel. You need to be sure the board is not damaged or too worn out; in this case replace it.
- If the router is equipped with a cutter, remove it as described in par.5.14
- Once the tool has been removed, completely unscrew the nut and remove the collet.
- Fit the new nut with the relative supplied pliers and mount on it with the $\varnothing 35\text{mm}$ cutter (shank $\varnothing 8$) as described in par.5.12.
- Assemble the router and the suction system in the relative housings as described in par.5.19.
- Connect the Router its air-cooling system Figure 5-33.
- Turn on the pump on and open all the suction sectors.
- Turn the industrial vacuum cleaner on.
- On the PC open the V studio, then follow the instructions on the software manual.

Finish the leveling operations proceed as follows:

- Turn off the vacuum cleaner and the vacuum pump.
- Remove the router and the suction system from the relative housings.
- Remove the levelling cutter and its nut and collet.
- Reposition the slip sheet on top of the MDF panel.

7.2 CLEANING

One of the most important maintenance tasks is the frequent and complete cleaning of the following parts:

Electrical box filters (every 2 - 4 weeks)

- Switch the machine off
- Remove the protective grid (1) and afterwards the filter.
- Rinse or blow compressed air through the filter (2) to clean it.
- Clean the fan (3) if necessary.
- Clean the filter every 2 weeks if the machine is working high levels of production or is situated in a dusty environment.
- Change the filters every 12 months.

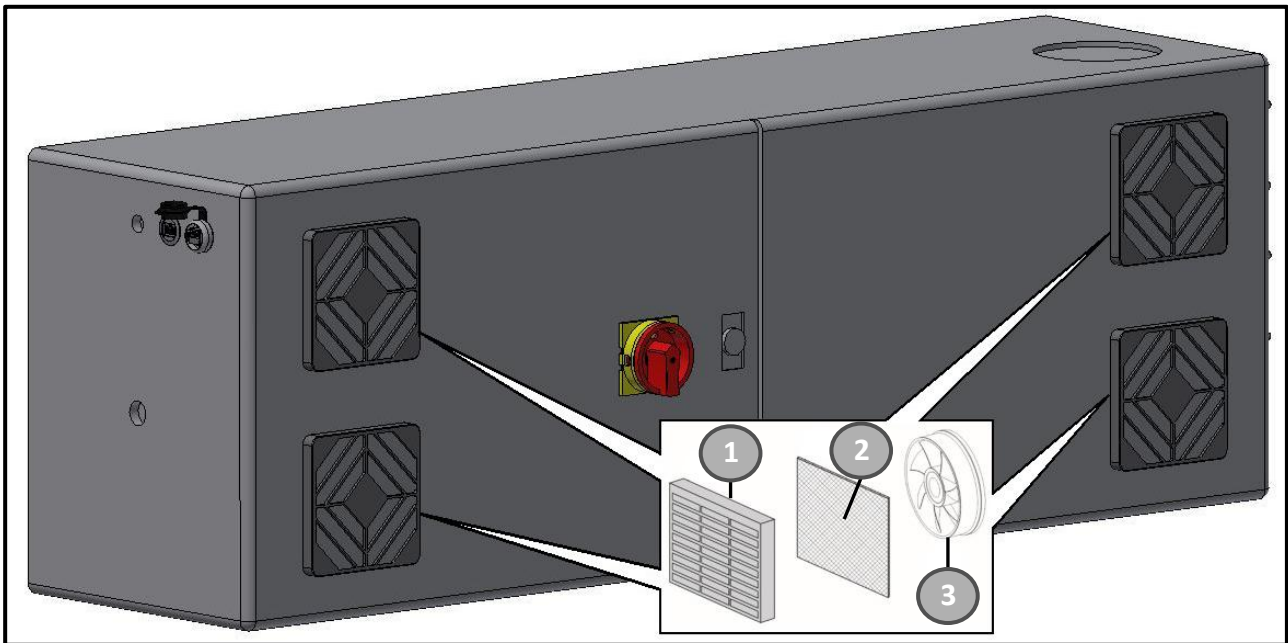

Figure 7-1

Worktable (daily)

- Clean the top of the worktable everyday with compressed air or with a soft and dry brush.
- Carefully clean under the material clamps and remove any residual scraps of material or any dirty stuff that might be deposited there.

Cutting head (daily)

- Clean the cutting head using compressed air or with a soft dry cloth to remove dust and any debris left from production.



DANGER! Before cleaning the cutting tools remove the blade to avoid any accidental injury.

7.2.1 ROUTER CLEANING PROCEDURE



On no account clean the motor spindle with ultrasound, steam jet, compressed air, or similar.

Under no circumstances should detergents (e.g., spray cleaner, grease solvents, etc.) get into the inside of the motor spindle.

Motor spindle cleaning (daily):

When cleaning the motor spindle, leave the sealing air connected and the replace the cutter with a cylinder pin to prevent deformations on the collet-chuck. The pin must be clamped so that the external edge protrudes about 1 cm. This operation will prevent dirt from being collected inside the motor during the cleaning. Clean the motor spindle with a fibre-free cloth.

Cleaning cone and collet-chuck (daily):

After the motor spindle is cleaned, remove the collet-chuck from the motor spindle and clean the shaft cone and the collet/chuck, e.g., with a brush.

Inspect the power supply lines (every week):

Check the power supply lines of the motor spindle. Media must be able to reach the motor spindle without hindrance. The power cord must not be kinked or squashed. Check the entire power cord for damage and double-check the media settings.

7.3 LUBRICATION

Cutting blade running guide (every 1 - 2 months for all versatool cutting heads type)

Remove the blade as previously described. Lubricate the guide at points (1) and (2) with a small amount of spray grease taking particular care not to allow any grease to reach the rubber roller. Carefully wipe off all excess grease before re-inserting the cutting blade. It is essential that you do not allow any lubricant to come into contact with the rubber roller.

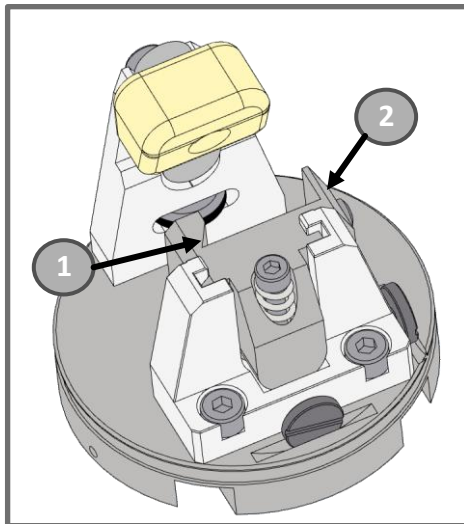

Figure 7-2



CAUTION! Use only a synthetic grease spray based on petroleum jelly. Avoid using conventional oils as they can cause a dust accumulation and paper dust scraps on the cutting head guides and could leave traces of oil on the material being cut.

7.4 PNEUMATIC SYSTEM MAINTENANCE (EVERY 1-2 MONTHS)

Make sure the tanks (A)(C) of the air treatment unit located at the entry to the pneumatic circuit of the machine does not contain any water generated by the compressor and if so, empty the tank releasing the valve (B). Check the oil level as well and if necessary, re-fill it following the below steps;

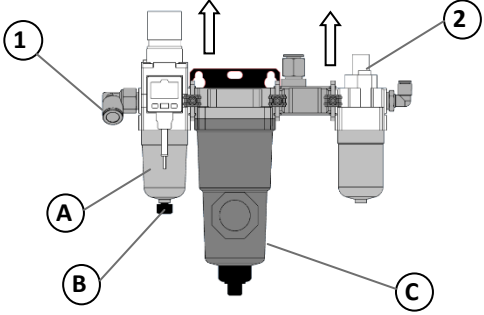
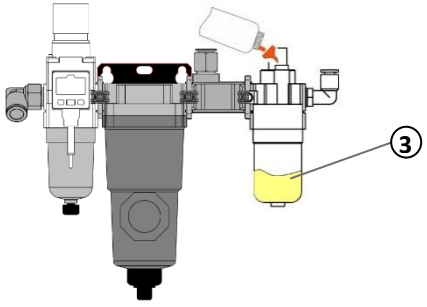
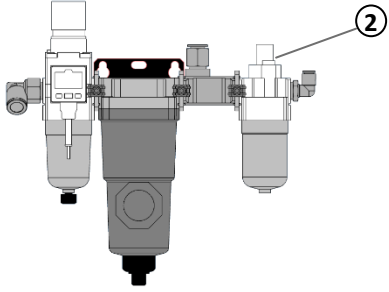
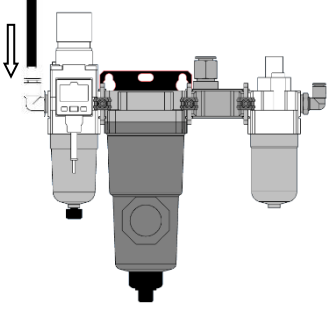
	<p>Turn off the compressor (or close the pneumatic system valve if present near work zone) and remove the main air pipe (1). Unscrew the cap (2) of the tank.</p>
	<p>Re-fill the tank with a funnel until the oil reaches the level indicated in the figure (3). An oil suitable for a pneumatic system with a viscosity of ISO VG 32 or max 46 is recommended.</p>
	<p>Re-insert the cap (4) and tighten gently. Attention! Over-tightening could break the tank's thread generating air and oil loss.</p> <p>The quantity of oil released in the pneumatic circuit is regulated by the manufacturer during the testing phase before the machine is shipped.</p> <p>NOTE! For sufficient lubrication, the oil flow adjustment knob must be between 1 and 2.</p>
	<p>Re-connect the air hose, turn the compressor back on (or open the pneumatic system valve if present near work zone) and make sure there is no air leaking before operating the machine.</p>



CAUTION! Use only the oil suggested in the previous table to top off pneumatic system tank.

8 TROUBLE SHOOTING

This section relates to possible problems that could occur during normal use of the machine. For any problems not covered in this manual please contact your sales representative, your nearest dealer or the technical support.

8.1 CONNECTION PROBLEMS

The-connection error message reports when the V-Studio software is not capable to link with the machine. There might be several reasons that could generate this issue;

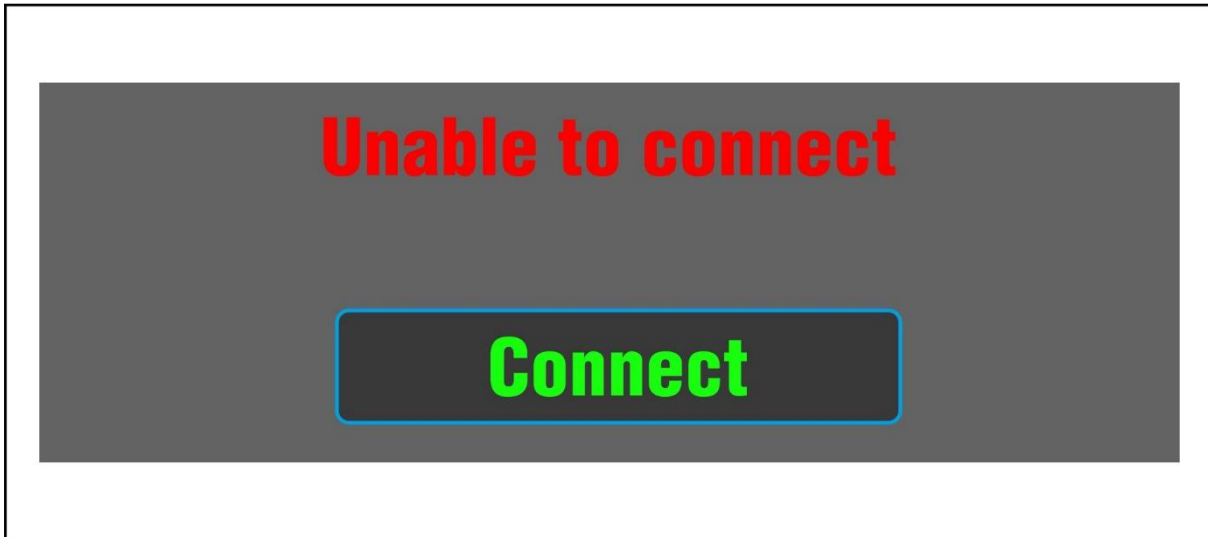

Figure 8-1

- The Ethernet cable connecting the PC with the machine is disconnected or damaged.
- The machine IP setting is incorrect. (For software / machine connection and parameter settings, see the adjustments section of the software manual).
- The main switch on the electrical control panel is not in the "ON" position.
- Smart Cut process might be not close correctly and still running underneath. Please check thru the task manager.
- The PC has turned the some componets off after a long "stand-by" period. This interupt the connection with the machine and might require a PC reboot.. Check, and if necessary, change the Windows settings to avoid partially closing down the system on "Standby"



CAUTION! Always ensure that the Ethernet cable is connected correctly and that the machine is always switched on before opening V-Studio.

9 DECOMMISSIONING AND DISMANTLING

When dismantling or disposing of the machine it should always be noted that:

- The client, under 91/689/EEC directives, or byelaws in force in the relevant country, is responsible for the disposal of the machine and its components.



NOTE! Qualified people who have knowledge of the appropriate laws and methods to use should conduct the dismantling and re-cycling operations.



DANGER! During dismantling of the machine, ensure that the parts being removed are within limits for a workman to carry (max. 25 Kg) and that there is no risk of anything falling and causing injury.



DANGER! When dismantling the machine pay particular attention that it does not become unbalanced. This could be dangerous for anyone in the immediate vicinity whether involved, or not involved, in the dismantling operation.

- The machine should be dismantled in order to effectively separate the various materials used in its construction.
- Proceed with emptying the oil in the air pressure regulator ensuring that it is disposed of as necessary under EEC law or the law of the country prevailing in the country of disposal.



CAUTION: Discarding oil into the drainage system is prohibited.

- All plastic and electrical materials should be taken to authorised recycling organisations.
- Where possible recycle motors, transformers and electro-mechanical components otherwise take them to official industrial waste sites.
- All ferrous metals should be taken to authorised recycling centres.
- The standby batteries should never be discarded into the environment as they are classed as pollutants and therefore should be disposed of by authorised centres.

9.1 HAZARDOUS SITUATIONS

In the case of a fire use CO² extinguishers so as not to damage electrical components.

In the case of fire use powder extinguishers type ABC + Nitrogen to limit the damage in areas not containing electrical components.

10 DOCUMENTATION SUPPLIED WITH THE MACHINE

The instruction and maintenance manual of the machine is accompanied by the following documents:

- V-Studio software manual.
- Vacuum pump manual
- Electrical system diagram.
- Warranty & replacement parts shipment form.

11 WARRANTY EXTENSION

5 YEAR WARRANTY

We have always been committed to ensuring the highest quality of our products, and it is precisely for this reason that we offer an extension of the warranty to 5 years for our machines, at no additional cost. The only requirement to take advantage of the warranty extension is to activate it online when registering the machine on the support section of the Summa website, in the V series Warranty & Support section, within 30 days from the date of installation, coinciding with the machine's first start-up.

WARRANTY CONDITIONS

The 5-year warranty will only be valid if activated within the time and manner requested; otherwise the machine, purchased from Valiani or an authorized Valiani dealer, including the mechanical, pneumatic, electrotechnical and electronic components will be guaranteed to conform to the Valiani production specifications for a period of one (1) year from the date of product installation/activation coinciding with the date of the machine's first start-up, automatically recorded by the machine's software system (Standard Warranty). The technical support service and free remote connection is valid for one (1) year. Upon expiry it will be possible to request an extension for a fee. The 5-year warranty is only available for the Optima, Invicta, Integra V-series. The 5-year warranty is available in all countries*.

CONTENT

During the Warranty Period, Valiani will, at its discretion, repair or replace the machine that does not comply with the Warranty without additional costs, with the exception of travel and labor costs relating to Valiani personnel sent to the site.

The repair, at Valiani's discretion, may involve software updates, replacement of components or boards with others of equivalent functionality, whether new or refurbished. Replaced components, accessories, batteries, or boards are covered by the remaining duration of the original warranty period. As such, the Warranty Period will not be extended in any way. The substituted machine, original accessories, and/or replaced mechanical and electronic components become the property of Valiani.

METHOD

To obtain warranty assistance, the buyer must contact Valiani no later than eight (8) days from the discovery date of the defect in materials, workmanship, or non-compliance with the product's specifications, and before the expiration of five (5) years from the installation/activation of the machine.

In the event that a specific part of the machine is requested to be returned to Valiani or an authorized Valiani dealer, the product must be sent with shipping costs to be paid by the owner/customer, in accordance with Valiani's RMA procedures. This warranty will be void if the RMA procedures are neglected or not properly followed. In the case of a warranty replacement order with a request to return the defective part, if the buyer does not ship it back to Valiani within forty-five (45) days of receipt, Valiani will issue an invoice for each item replaced and not returned.

WARRANTY EXCLUSIONS

This warranty is not valid on consumable parts or wear parts and if the origin of the fault is not attributable to product defects but to external factors such as, purely by way of example and not exhaustively:

1. Use that does not comply with the indications of the user manual (incorrect use), tampering, negligence, or neglect and in the case of alterations or repairs carried out by personnel not authorized by Valiani.
2. Use of accessories, software applications and peripherals (including but not limited to: batteries, USB adapters and power supplies), not manufactured, supplied, or expressly authorized by Valiani.
3. Use of blades or components not produced, supplied or expressly authorized by Valiani.
4. Connection to incompatible energy sources, supercharging the machine, or the connection to an earthing system not in accordance with the law.
5. Use of connection cables to the electric control unit of the Product that are elongated, modified, damaged or have been crushed or short-circuited.
6. When defects or damages are due to humidity, liquids or other infiltrations.

Oscillating tool, 1Kw Router, Vacuum pump and Industrial Vacuum Extractor are excluded from the 5-year warranty.

In addition, this warranty will not apply if the serial number of the Product has been modified, deleted, duplicated, removed or made illegible. Valiani reserves the right to refuse free assistance if the requested documentation cannot be provided or if the information is incomplete, illegible or incompatible with the factory data.

DATA BACK-UP

Before sending your Product or a specific part of the machine for warranty service, please take note and backup all the data that you have entered for your product, such as the library, the settings for the machine setup and any adjustments for cutting, as this data could be deleted during the repair or service operation.

OUT OF WARRANTY REPAIRS

In the event that the customer requests Valiani to perform a repair of the machine or a specific part of the machine beyond the Warranty Period, or if the Warranty cannot be applied due to the nature of the defect(s) or malfunction(s), Valiani, at its discretion, may carry out these repairs and charge for the costs incurred.

* Except China and Hong Kong

DECLARATION OF CONFORMITY



The manufacturer:

VALIANI S.r.l.

REGISTERED OFFICE:

Via delle Regioni, 305-307 – 50052 Certaldo [FI] - ITALIA
 Tel. (+39) 0571 666 598
 www.valiani.com – email: info@valiani.it

***Declares under our sole responsibility that the machine
 has been made in compliance with the following directives***

- **Directive 2006/42/EC** of the European Parliament and of the Council on machinery.
- **Directive 2014/35/EU** of the European Parliament and of the Council on the harmonisation of the laws of the Member States relating to the making available on the market of electrical equipment designed for use within certain voltage limits.
- **Directive 2014/30/EU** of the European Parliament and of the Council on the harmonisation of the laws of the Member States relating to electromagnetic compatibility.
- **Directive 2011/65/EU** of the European Parliament and of the Council on the restriction of the use of certain hazardous substances in electrical and electronic equipment, as amended.

The technical documentation has been compiled in accordance with Annex VII A of Directive 2006/42/EC.

Person authorized to compile and keep the technical documentation:			
Name:	NICO	Surname :	VALIANI
Address	Via delle Regioni, 305-307	Country:	Certaldo [FI] - ITALIA
Corporate position:	Chief Executive Officer		

13 INTEGRA DIMENSIONS

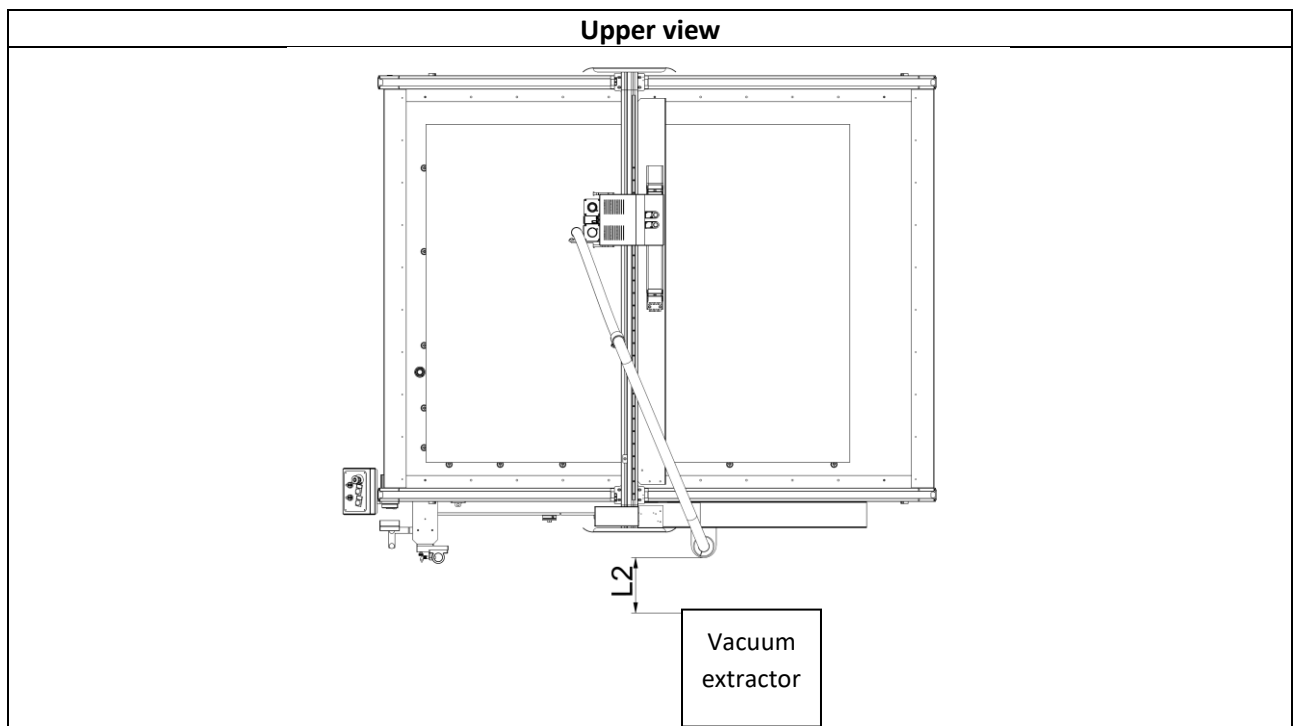
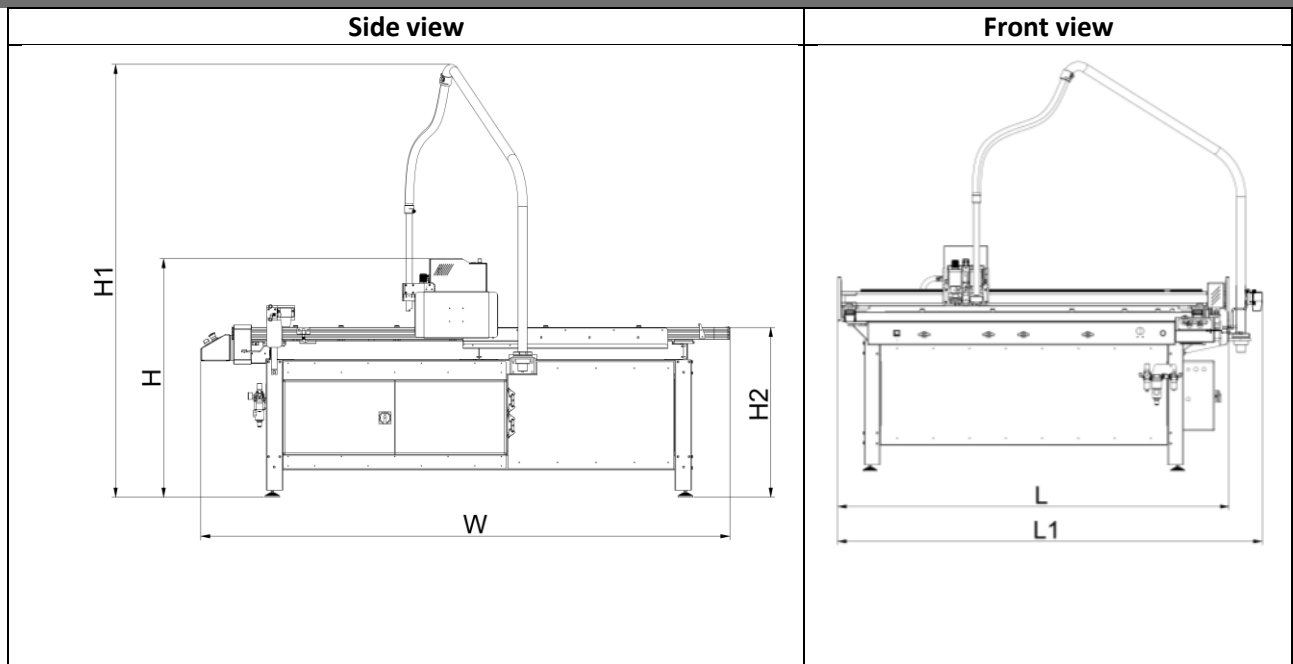

Mod.	W	Without Router tool			With Router tool		
		H	H2	L	H1	L1	L2
V1225	3285 (129.33")	1285 (50.59")	905 (35.63")	1885 (74.21")	2335 (91.92")	2065 (81.3")	450 (17.71")
V1612	2045 (80.51")			2110 (83,07")	2430 (95.67")		
V1620	2845 (112")			2225 (87,6")			
V1630	3855 (151.77")			2335 (91.92")			

Note: All measurements outside brackets are in millimetres, while those in brackets are in inches

Summa / **valiani**
your perfect cut

Valiani srl
Via delle Regioni 305
50052 Certaldo - Florence - Italy
info@valiani.com - valiani.com